

NEFF

B A L L S C R E W S

Screw drives Screw Jacks

09/2016

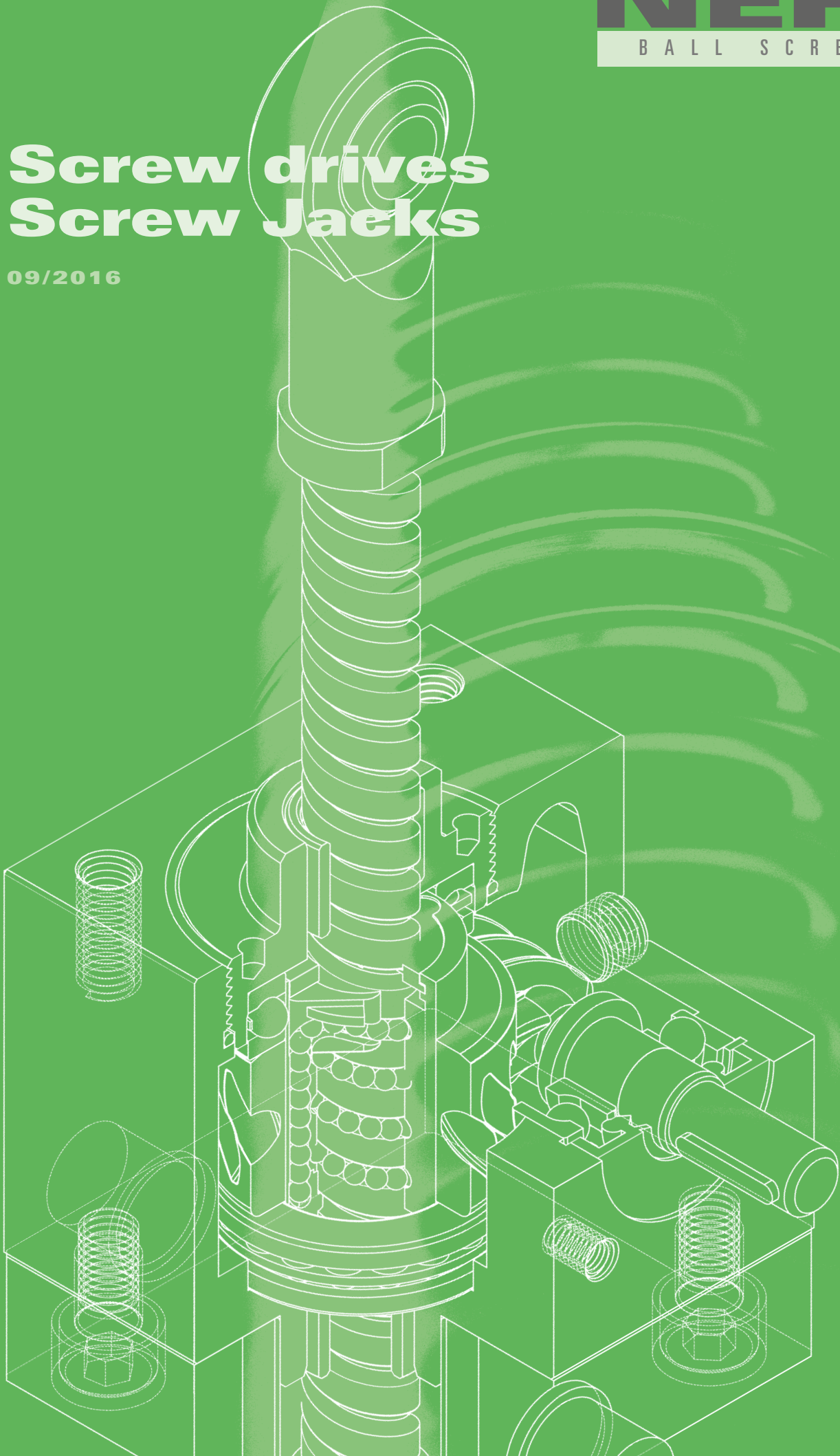

Neff moves!

The name NEFF traditionally stands for high-quality screw drives. For over 100 years threads have been cut, spun, rolled or grounded. Today NEFF Gewindetriebe GmbH is a highly qualified development and manufacturing company. Our screw drives and lifting systems move machines and plants in the most diverse industries all over the world.

It has always been noticeable with NEFF that everything revolves around the customer. Not only do we supply first-class products; we as the NEFF team aim to offer customer-oriented, sustainable solutions. We want to pass on our extensive experience and communicate openly.

Entirely in keeping with this style, this revised and extended catalogue not only lists our stock standards, but is also intended to communicate basic technical principles in order to support the

user with the various drive tasks.

Regardless of whether you are a long-standing NEFF customer or whether you are just discovering us as a new customer – we look forward to cooperating with you.

On behalf of the entire NEFF team,
Your



Hartmut Wandel
Chief Executive Officer



Here you can find us:

NEFF Gewindetriebe GmbH

Location Heilbronn

Ochsenbrunnenstraße 10
D-74078 Heilbronn

Phone 07131 27177-60

Fax 07131 27177-66

NEFF Gewindetriebe GmbH

Karl-Benz-Straße 24
D-71093 Weil im Schönbuch

Phone 07157 53890-0

Fax 07157 53890-25



Contents

Overview	4	High-performance joint head HG	101
Ball screw drive KGT		3-phase motors.....	102
General technical data	7	Handwheels.....	104
Ball screws KGS	8	Motor adaptor flanges MG	106
Ordering code for ball screws.....	9	Couplings.....	108
Ball nuts KGM/KGF.....	10	Universal joint shaft	111
Ordering code for ball screws.....	15	Pedestal bearings	113
Calculation Ball screw drive.....	16	Bevel gearboxes	114
		Ordering code Bevel gearboxes.....	123
Trapezoidal screw drive TGT		Installation and maintenance	124
General technical data	22	Telescopic Screw Drive S-TEG	125
Trapezoidal threaded spindle	23	General technical data	125
Calculation Trapezoidal threaded spindle	25	Dimensions - Design	126
Trapezoidal-threaded nut TGM.....	26	Ordering Code S-TEG	129
Ordering code Trapezoidalscrew drive	31	General Accessories	130
Calculation Trapezoidal screw drive.....	32	Bellow.....	130
		Spiral spring cover SF	132
Accessories KGT and TGT		Lubricants.....	135
Screw end machining	38	Lubricant dispenser	136
Fixed bearing units	43	Questionnaires	
Grooved nuts	49	Questionnaire NEFF-KGT/TGT	137
Adaptor bracket	50	Questionnaire NEFF-SHG Series M/J/G.....	138
Universal joint adapter	52	Contact person	141
Installation and maintenance	53		
Screw Jacks			
General technical data	55		
Dimensions and Versions.....	56		
Performance table	61		
Ordering code Worm gear screw jacks.....	64		
High-Performance Screw Jacks MH/JH			
Technical Data.....	65		
Dimensions - Design N.....	66		
Performance tables High-Performance Screw Jacks MH/JH.....	71		
Ordering Code High-Performance Screw Jacks MH/JH	77		
High-speed screw jacks G1-G3	78		
Performance tables G1-G3.....	81		
Shaft assemblies/Vent Valve	83		
Ordering code High-speed screw jacks	87		
Examples of arrangements and direction of rotation.....	88		
Calculation screw jacks.....	90		
Accessories Screw Jacks			
Mounting feet.....	97		
Universal joint adapter	98		
Universal joint bearing	99		
Top plate BP.....	100		
Fork end GK.....	100		
Spherical bearing GA	101		

Overview

NEFF Screw drives

Trapezoidal screw drives

NEFF trapezoidal screws are manufactured from special semi-finished goods with high demands on straightness. The series conforms to DIN 103 and offers an extensive range of nuts made from various materials – all ready for installation. The very low backlash in the nuts allows low radial forces to be absorbed.

Trapezgewindespindeln

- Precision-rolled trapezoidal screws RPTS, Ø 10 – 80 mm in versions with single or multi-start threads.
- Planetary-milled trapezoidal screws WPTS, Ø 16 – 120 mm (the trapezoidal screws can also be supplied in coated and rustproof versions).

Trapezoidal nuts

- KSM, steel nut, round, Ø 10 – 80 mm
- SKM, steel nut, hexagonal, Ø 10 – 80 mm
- SFM, red bronze, ready to install, Ø 10 – 80 mm
- LRM, red bronze nut, Ø 10 – 80 mm
- EFM, red bronze, ready to install, Ø 10 – 80 mm
- Central flanged nut, bronze GBZ 12
- Central flanged nut, plastic, PTFE alloy
- Universal joint nut, bronze GBZ 12
- Universal joint nut, plastic, PTFE alloy
- Bracket nut, bronze GBZ 12
- Bracket nut, plastic, PTFE alloy

Screw drive accessories

The NEFF screw drive accessory range offers an extensive range of accessories for all common accessory parts of a screw drive, from ready-to-install bearing units to the appropriate spindle grease. If desired we also manufacture tailor-made solutions in our modern machine pool.

- End machining
- Fixed bearing/movable bearing units
- Grooved nuts
- Adaptor brackets KON
- Pivot adaptors KAR
- Bellows FB
- Spiral spring covers SF
- Lubricant dispensers
- Grease cartridges

Ball screw drives

The range conforms to DIN 69051 and the NEFF standard. All nuts (flanged and cylinder versions) can be supplied with the corresponding DIN connections. Pre-tensioned double-nut units achieve high positioning accuracies. Special nuts on enquiry. All ball screw drives are available with customer-specific end machining. On request we can supply soft-annealed ends for you to carry out your own end machining.

Ball screws

- Precision-rolled ball screws, Ø 12 – 80 mm
Pitch from 5 - 50 mm, pitch accuracies of 23 µm, 50 µm and 200 µm/300 mm
- polished ball screws, Ø 6-120 mm,
Pitch from 5 - 50 mm, pitch accuracies of 6-52 µm/300 mm

Ball nuts

- KGF-N NEFF flanged single nut
 - KGF-D DIN DIN flanged single nut
 - KGM-N NEFF cylinder single nut
 - KGM-N DIN cylinder single nut
 - KGM-E screw-in cylinder single nut
- (the ball nuts can also be supplied free of play and pre-tensioned in conjunction with spindles.)

Telescopic screw drives S-TEG

2-stage synchronously extending telescopic screw drive as a sliding screw or ball screw variant. Available designs include the tried-and-tested "N" version (lifting spindle) and the "VK" anti-twist version, optionally with limit switches. You can choose from standardised connecting options for gear, toothed belt or direct connection of a drive motor by means of motor adapter flange and coupling. The variants can be selected via the product code.

- Available as a ball screw or sliding screw variant
- 3 different connecting options to choose from
- Available as N or VK version

Overview

NEFF Screw Jacks

Worm Gear Screw Jacks

The range encompasses 11 sizes with lifting forces from 2.5 to 500 kN, with fixed and rotating spindles.

- Some sizes are available as standard with lifetime lubrication
- Significantly improved efficiency through optimisation of tolerances and surface quality
- Limited absorption of lateral forces through the use of the NEFF glide screw
- Optionally also available with ball screw or trapezoidal screw drive
- Mountable in any position thanks the cubic design

High-performance worm gear screw jack MH/JH

The product range comprises 6 sizes with a lifting capacity of 5-250 kN with fixed, anti-twist or rotating spindle.

- All screw jacks feature oil lubrication as a standard
- Maximum efficiency thanks to optimised high-performance worm gear
- Supplied with either ball or trapezoidal screw
- The cubic design permits any mounting position

High-speed screw jacks

NEFF high-speed screw jacks supplement the existing screw jack range in the medium load range for high stroke speed and higher duty cycle.

- 3 sizes
- Gearboxes with ratios of 1:1, 2:1 and 3:1 available
- Hardened, polished and spiral-toothed bevel gearboxes
- Mountable in any position thanks to the cubic design
- Available with up to 4 output shafts (except transmission ratio 1:1)

Screw jack accessories

The NEFF screw jack accessory range offers an extensive selection of accessories for all common accessory parts of a screw jack, from precise pivot bearings to the appropriate grease dispenser. If desired we also manufacture tailor-made solutions in our modern machine pool.

- Bevel gearboxes
- Fastening strips BLL
- Pivot adaptors KA
- Pivot bearing flange
- Pivot bearing pedestal
- Mounting plate BP
- Limit switch
- Fork end GK
- Spherical bearing GA
- High-performance rod end HG
- Spiral spring cover SF
- Three-phase motors M
- Motor adaptor flanges MG
- Shaft coupling GS
- Shaft coupling RA, RG
- Universal joint shaft ZR
- Universal joint shaft GX
- Pedestal bearing SN
- Grease cartridges
- Lubricant dispensers
- Adaptor brackets KON
- Pivot adaptors KAR

General accessories

The range of general accessories comprises products such as grease designed specifically for screw drives or universal lubricant dispensers.

- Bellows FB
- Spiral spring covers SF
- Lubricant dispensers
- Grease cartridges

Ball screw drive

Ball screw drives from Neff screw drives are the result of many decades of innovative further development of the ball screw drive.

We offer ball screw drives in all common sizes in precision-rolled versions at competitive prices, in extraordinary quality and with a complete quality concept.

The Neff ball screw range corresponds to DIN 69051 and the NEFF standard (exchangeability of EFM trapezoidal nuts to ball screw nuts)

The spindles are available with customised end machining, or on request with soft-annealed ends for your own machining.

The high mechanical efficiency < 98% requires a lower drive power and a significantly lower breakaway torque than with trapezoidal screw drives.

Thanks to the low rolling friction and deflection systems that have been developed further over many years, Neff ball screw drives have a particularly long and reliable service life

Neff ball screw drive with channel deflection:



General technical data

Manufacturing process

The thread profile of NEFF ball screws is produced by cold rolling in the thread rolling method. Both screw and nut have an arched thread profile. The load angle is 45°.

Linear speeds

At present the permissible speed limit is in the region of 3000 rpm, with individual dimensions up to 4500 rpm. This limit defines the maximum speed, which may be run only under ideal operating conditions.

Installation position

The position in which the screw drive is installed can always be freely chosen. Please consider that all radial forces that occur need to be absorbed by external guides.

Accuracy classes of the spindles

T5 = pitch accuracy 23 µm/300 mm

T7 = pitch accuracy 52 µm/300 mm

T9 = pitch accuracy 130 µm/300 mm

T10 = pitch accuracy 200 µm/300 mm

If nothing different is specified we deliver class T7.

Self-locking

Ball screw drives are generally not self-locking due to the low friction. It is therefore advisable to install suitable motors with holding brake, particularly when the ball screw drive is installed vertically.

Efficiency

Trapezoidal screw drives have a max. mechanical efficiency of 50 %, ball screw drives achieve a mechanical efficiency of up to 98 %.

Duty cycle

The ball screw drive permits a duty cycle of up to 100 %. Extremely high forces in combination with high duty cycles can shorten the service life.

Temperatures

All screw drives are designed for continuous operation at ambient temperatures of -30 °C up to 80 °C. Temperatures of up to 110 °C are also permitted for brief periods. Ball screw drives are suitable only in exceptional cases for operation at sub-zero temperatures.

Repeatability

The repeatability is defined as the capability of a screw drive to reach an actual position again that has been reached once before under the same conditions. It refers to the average position variation according to VDI/DGQ 3441. The repeatability is influenced amongst other things by:

- Load
- Speed
- Deceleration
- Direction of travel
- Temperature

Aggressive operating conditions

In cases of heavy dirt and fine dust particles/swarf, an additional bellow or a spiral spring cover is recommended.

Neff ball screw profiles

Neff ball screw profiles have a Gothic pointed arch profile with a 45° contact angle and optimised osculation. (Ratio of ball race radius to ball diameter)

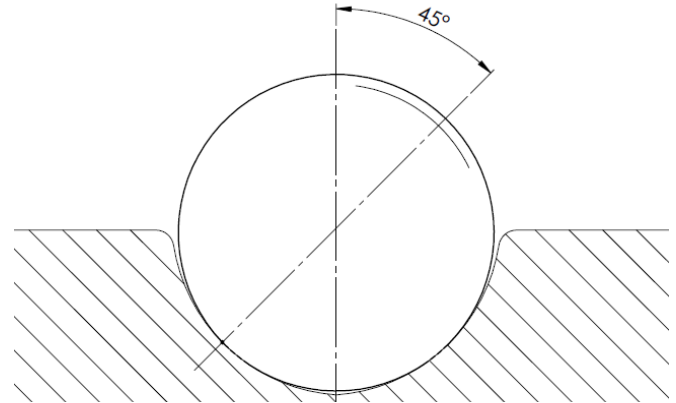

Neff deflection systems

Single deflection:

In this type of deflection the balls are lifted up out of the spindle after each circuit and set back by one thread pitch. (Only for single-start ball screw drives)

Channel deflection:

In channel deflection the balls, after several circuits, are steered by an integrated deflection piece into a return channel in the nut and fed back (For single-start and multi-start ball screw drives)

Cover deflection:

In cover deflection the balls are steered via special deflection covers into the return channel in the nut and fed back. (For multi-start ball screw drives)

Types of pre-loading:

In principle all Neff ball screw nuts are combinable for a backlash-free, O-pre-loaded nut unit if a ball screw drive is selected with a pitch accuracy of $\leq T7$.

With less accurate pitch classes only low-backlash can be set ($\geq 0.03\text{mm}$)

O-pre-loading:

In the O-pre-loading the force lines run with a diamond form, i.e. the nuts are pressed apart by a specially manufactured intermediate piece. The standard pre-loading is about 10% of the dynamic load rating C_{dyn}

Pre-loading by ball selection:

The ball screw nut can be adjusted for low backlash by means of ball selection.

Ball screws KGS

Technical data ball screw KGS

- Diameter: _____ Standard: 12 – 80 mm
- Pitch: _____ Standard: 5 – 50 mm
- Number of starts: _____ 1 – 5
- Thread direction: _____ Right hand thread,
KGS 2005 + 3205 also
left hand thread
- Length: _____ Standard: 5600 mm
KGS 1205: 2000 mm
to 11000 mm auf Anfrage
- Material: _____ 1.1213 (Cf 53)
Ball track inductively hardened
and polished, Spindle end and
spindle core soft
- Straightness: _____ L < 500 mm: 0,05 mm/m
L = 500 – 1000 mm: 0,08 mm/m
L > 1000 mm: 0,1 mm/m
- Right-hand/left-hand spindle: _____ KGS 2005 + 3205 only

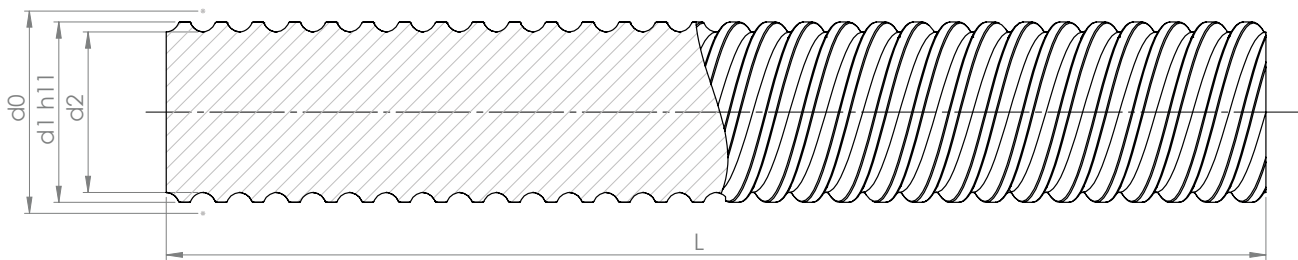

d0= nominal diameter, d1= outside diameter, d2= core diameter, L= spindle length

Type Diameter [mm] Pitch [mm] Right hand thread Division	Ball size	Dimensions [mm]				Distributed load W_{KGS} [kg/m]	Geometrical moment of inertia I_y [10^4 mm^4]	Moment of resistance ¹⁾ [10^3 mm^3]	Mass moment of inertia [$\text{kg m}^2/\text{m}$]
		d_0	d_1	d_2	L max.				
KGS-1205	2	12	11.5	10.1	2000	0.75	0.051	0.101	$1.13 \cdot 10^{-5}$
KGS-1605	3.5	16	15.5	12.9	5600	1.26	0.136	0.211	$3.21 \cdot 10^{-5}$
KGS-1610-P5	3	16	15.4	13.0	5600	1.26	0.140	0.216	$3.21 \cdot 10^{-5}$
KGS-1616-P8	3	16	15.4	13.0	5600	1.26	0.140	0.216	$3.21 \cdot 10^{-5}$
KGS-2005	3.5	20	19.5	16.9	5600	2.04	0.400	0.474	$8.46 \cdot 10^{-5}$
KGS-2020-P5	3.5	20	19.5	16.9	5600	2.04	0.400	0.474	$8.46 \cdot 10^{-5}$
KGS-2050-P10	3.5	20	19.1	16.5	5600	2.04	0.364	0.441	$8.46 \cdot 10^{-5}$
KGS-2505-P5	3.5	25	24.5	21.9	5600	3.33	1.129	1.031	$2.25 \cdot 10^{-4}$
KGS-2510-P5	3.5	25	24.5	21.9	5600	3.33	1.129	1.031	$2.25 \cdot 10^{-4}$
KGS-2520-P5	3.5	25	24.6	22.0	5600	3.33	1.150	1.045	$2.25 \cdot 10^{-4}$
KGS-2525-P5	3.5	25	24.5	22.0	5600	3.33	1.150	1.045	$2.25 \cdot 10^{-4}$
KGS-2550-P10	3.5	25	24.1	21.5	5600	3.33	1.049	0.976	$2.25 \cdot 10^{-4}$
KGS-3205	3.5	32	31.5	28.9	5600	5.63	3.424	2.370	$6.43 \cdot 10^{-4}$
KGS-3210	7.144	32	32.7	27.3	5600	5.63	2.727	1.998	$6.43 \cdot 10^{-4}$
KGS-3220-P10	5	32	31.7	27.9	5600	5.63	2.974	2.132	$6.43 \cdot 10^{-4}$
KGS-3240-P10	3.5	32	30.9	28.3	5600	5.63	3.149	2.225	$6.43 \cdot 10^{-4}$
KGS-3260-P10	3.5	32	30.9	28.3	5600	5.63	3.149	2.225	$6.43 \cdot 10^{-4}$
KGS-4005	3.5	40	39.5	36.9	5600	9.01	9.101	4.933	$1.65 \cdot 10^{-3}$
KGS-4010	7.144	40	39.5	34.1	5600	8.35	6.737	3.893	$1.41 \cdot 10^{-3}$
KGS-4020-P10	5	40	39.7	35.9	5600	9.01	8.154	4.542	$1.65 \cdot 10^{-3}$
KGS-4040-P10	3.5	40	38.9	36.3	5600	9.01	8.523	4.696	$1.65 \cdot 10^{-3}$
KGS-5010	7.144	50	49.5	44.1	5600	13.50	18.566	8.420	$3.70 \cdot 10^{-3}$
KGS-5020-P10	7.144	50	49.5	44.1	5600	13.50	18.566	8.420	$3.70 \cdot 10^{-3}$
KGS-6310	7.144	63	62.5	57.1	5600	22.03	52.181	18.280	$9.84 \cdot 10^{-3}$
KGS-8010	7.144	80	79.65	74.2	5600	36.43	148.600	39.950	$2.69 \cdot 10^{-2}$
Left hand thread									
KGS-2005 LH	3.5	20	19.5	16.9	5600	2.04	0.400	0.474	$8.46 \cdot 10^{-5}$
KGS-2505 LH	3.5	25	24.5	21.9	5600	3.33	1.129	1.031	$2.25 \cdot 10^{-4}$
KGS-3205 LH	3.5	32	31.5	28.9	5600	5.63	3.424	2.370	$6.43 \cdot 10^{-4}$

¹⁾ The polar resistive torque is twice as large as the resistive torque

Ordering code

Ball screws

Ordering code for ball screws

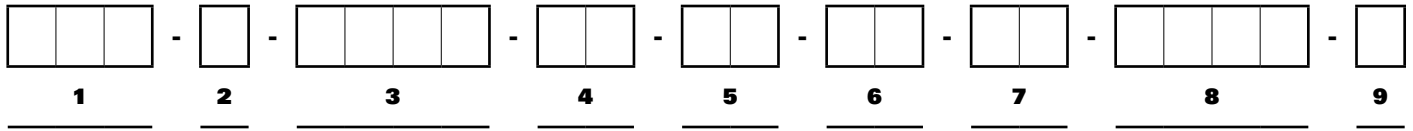

No.	Designation	Code	Description
1	Product abbreviation	KGS	Ball screw
2	Spindle abbreviation	R	Rolled
		W	Spun
		S	Grounded
3	Thread designation		e.g. 2005 (diameter 20 mm, pitch 5 mm)
4	Accuracy class of the spindle	T5	23µ/300 mm
		T7	50µ/300 mm
		T9	130µ/300 mm
		T10	200µ/300 mm
5	Pitch direction	RH	Right-hand thread
		LH	Left-hand thread
6	Spindle end A	0	Ends only sawn and brushed
7	Spindle end B	A	End with chamfer
		GA	1st end annealed (indicate length in the additional text)
		GB	2nd end annealed (indicate length in the additional text)
		K	End according to customer drawing or project drawing no.
		D	End fixed bearing form D for bearing ZKLF
		F	End fixed bearing form F for bearing ZARN
		H	End fixed bearing form H for bearing ZARF/LTN
		J	End fixed bearing form J for bearing FDX 12-40
		L	End fixed bearing form L for bearing 7201-7208
		S	End movable bearing form S for bearing 6001-6211
		T	End movable bearing form T for needle bearing HK1614-4518
		W	End movable bearing form W for bearing 6001-6211
		Fk	End fixed bearing unit FK4-FK30
		FF	End movable bearing unit FF6-FF30
		BK	End fixed bearing unit BK10-BK40
		BF	End movable bearing unit BF10-BF40
M	Metric threaded stem SHG		
AS	End hollowing safeguard SHG		
RS	End worm gear connection rotary spindle SHG		
VS	End anti-twist device SHG		
Z	cylindrical bearing journal SHG with rotary spindle		
8	Overall length in (mm)		e.g. 1000
9	Special requirements	0	None
		1	According to specification, description or drawing

Flanged ball nuts KGF-D

according to DIN 69051

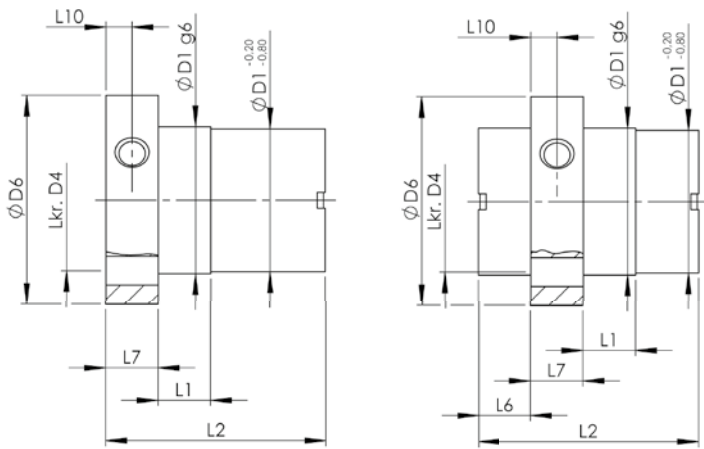

Form E

Form S

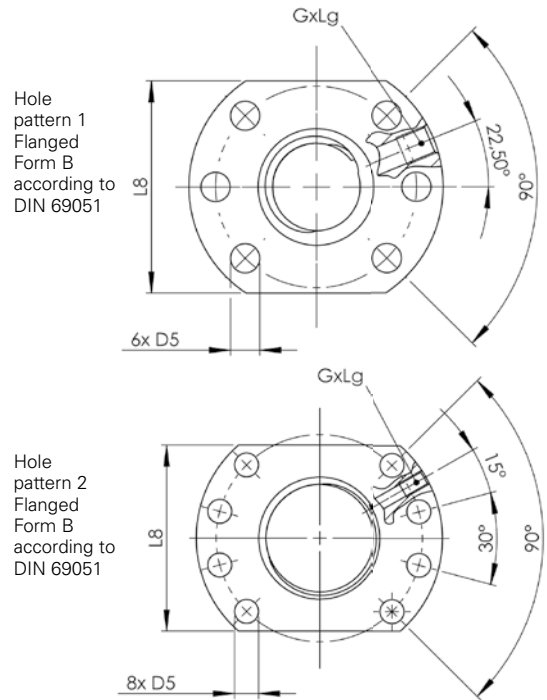
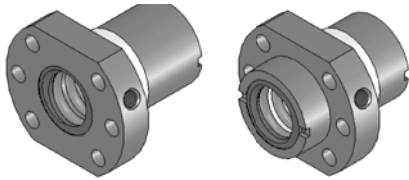

Material: 1.7131 (ESP65) or 1.3505 (100 Cr 6)

Type Diameter [mm] Pitch [mm] Right-hand thread	Form	Bore pattern	Dimensions [mm]											Lubrication bore G	Axial backlash max [mm]	No. of circuits	Load rating [kN]		
			D ₁	D ₄	D ₅	D ₆	L ₁	L ₂	L ₆	L ₇	L ₈	L ₉	L ₁₀				C ²⁾	C ³⁾	C ₀ = C _{0a}
KGF-D 1605 RH-EE	E	1	28	38	5.5	48	10	42	—	10	40	10	5	M 6	0.08	3	12.0	9.3	13.1
KGF-D 1610 RH-EE	E	1	28	38	5.5	48	10	55	—	10	40	10	5	M 6	0.08	6	23.0	15.4	26.5
KGF-D 1616-P8-3 RH-EE	E	1	28	38	5.5	48	10	55	—	10	40	10	5	M 6	0,08	6	23,0	15,4	26,5
KGF-D 1640-P10-3 RH-EE	S	1	32	42	5.5	52	10	45	10	10	40	8	5	M6	0,08	4	-	8,5	13
KGF-D 2005 RH-EE	E	1	36	47	6.6	58	10	42	—	10	44	10	5	M 6	0.08	3	14.0	10.5	16.6
KGF-D 2505 RH-EE	E	1	40	51	6.6	62	10	42	—	10	48	10	5	M 6	0.08	3	15.0	12.3	22.5
KGF-D 2510 RH-EE	E	1	40	51	6.6	62	16	55	—	10	48	10	5	M 6	0.08	3	17.5	13.2	25.3
KGF-D 2520 RH-EE	S	1	40	51	6.6	62	4	35	10.5	10	48	8	5	M 6	0.15	4	19.0	13.0	23.3
KGF-D 2525 RH-EE	S	1	40	51	6.6	62	9	35	8	10	48	8	5	M 6	0.08	5	21.0	16.7	32.2
KGF-D 2550 RH-EE	S	1	40	51	6.6	62	10	58	10.0	10	48	8	5	M 6	0.15	5	22.5	15.4	31.7
KGF-D 3205 RH-EE	E	1	50	65	9	80	10	55	—	12	62	10	6	M 6	0.08	5	24.0	21.5	49.3
KGF-D 3210 RH-EE ⁵⁾	E	1	53 ¹⁾	65	9	80	16	69	—	12	62	10	6	M 8x1	0.08	3	44.0	33.4	54.5
KGF-D 3220 RH-EE	E	1	53 ¹⁾	65	9	80	16	80	—	12	62	10	6	M 6	0.08	4	42.5	29.7	59.8
KGF-D 3260-P10-3,5 RH-EE	S	1	53	65	9	80	16	68	10	12	62	10	6	M 6	0,08	4,8	-	20	49,3
KGF-D 4005 RH-EE	E	2	63	78	9	93	10	57	—	14	70	10	7	M 6	0.08	5	26.0	23.8	63.1
KGF-D 4010 RH-EE	E	2	63	78	9	93	16	71	—	14	70	10	7	M 8x1	0.08	3	50.0	38.0	69.1
KGF-D 4020 RH-EE	E	2	63	78	9	93	16	80	—	14	70	10	7	M 8x1	0.08	4	44.5	33.3	76.1
KGF-D 4040 RH-EE	S	2	63	78	9	93	16	85	7.5	14	— ⁴⁾	10	7	M 8x1	0.08	8	42.0	35.0	101.9
KGF-D 5010 RH-EE	E	2	75	93	11	110	16	95	—	16	85	10	8	M 8x1	0.08	5	78.0	68.7	155.8
KGF-D 5020 RH-EE	E	2	85 ¹⁾	103 ¹⁾	11	125	22	95	—	18	95	10	9	M 8x1	0.08	4	82.0	60.0	136.3
KGF-D 6310 RH-EE	E	2	90	108	11	125	16	97	—	18	95	10	9	M 8x1	0.08	5	86.0	76.0	197
KGF-D 8010 RH-EE	E	2	105	125	13.5	145	16	99	—	20	110	10	10	M 8x1	0.08	5	-	82.7	221.9
Left-hand thread																			
KGF-D 2005 LH-EE	E	1	36	47	6.6	58	10	42	—	10	44	10	5	M 6	0.08	3	16.5	10.5	16.6

¹⁾ D₁ not conforming to DIN 69051.

²⁾ Dynamic load rating according to DIN 69051 part 4 draft 1978.

³⁾ Dynamic load rating according to DIN 69051 part 4 draft 1989.

⁴⁾ Round flange.

⁵⁾ Also available with Ø 50 mm according to DIN.

Flanged ball nuts KGF-N according to NEFF standard

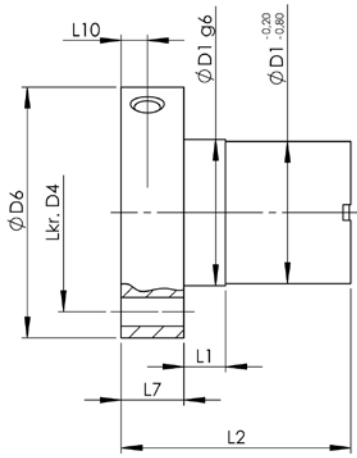

Form E

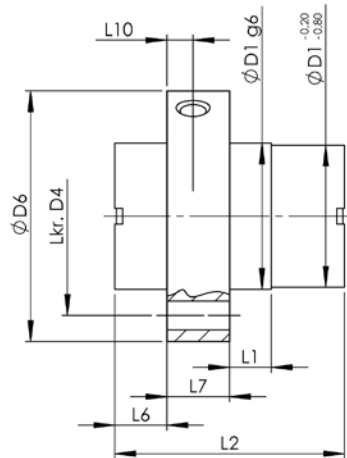

Form S

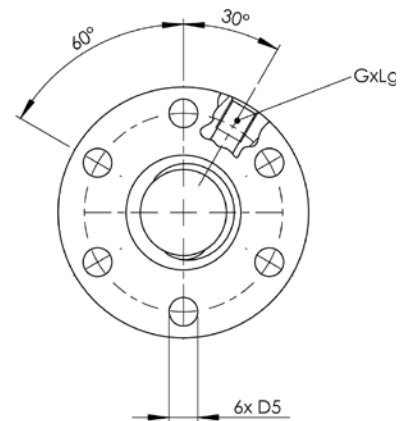

Bore pattern 3
Neff standard

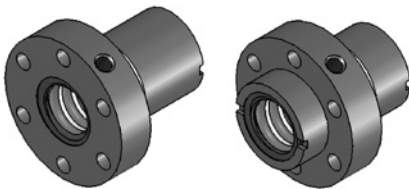

Material: 1.7131 (ESP65) or 1.3505 (100 Cr 6)

Type Diameter [mm] Pitch [mm] Right-hand thread	Form	Dimensions [mm]										Lubrication bore G	Axial backlash max [mm]	No. of circuits	Load rating [kN]		
		D ₁	D ₄	D ₅	D ₆	L ₁	L ₂	L ₆	L ₇	L ₉	L ₁₀				C ¹⁾	C ²⁾	C ₀ = C _{0a}
KGF-N 1605 RH-EE	E	28	38	5.5	48	8	44	–	12	8	6	M 6	0.08	3	12.0	9.3	13.1
KGF-N-1616-P8-3-RH-EE	E	28	38	5,5	48	8	45	–	12	8	6	M 6	0.08	3,75	–	10	16,4
KGF-N 2005 RH-EE	E	32	45	7	55	8	44	–	12	8	6	M 6	0.08	3	14.0	10.5	16.6
KGF-N 2020 RH-EE	S	35	50	7	62	4	30	8	10	8	5	M 6	0.08	4	12.0	11.6	18.4
KGF-N 2050 RH-EE	S	35	50	7	62	10	56	8	10	8	5	M 6	0.15	5	18.0	13.0	24.6
KGF-N 2505 RH-EE	E	38	50	7	62	8	46	–	14	8	7	M 6	0.08	3	15.0	12.3	22.5
KGF-N 3205 RH-EE	E	45	58	7	70	10	59	–	16	8	8	M 6	0.08	5	24.0	21.5	49.3
KGF-N 3210 RH-EE	E	53	68	7	80	10	73	–	16	8	8	M 8x1	0.08	3	44.0	33.4	54.5
KGF-N 3240 RH-EE	S	53	68	7	80	14	45	7.5	16	10	8	M 6	0.08	4	17.0	14.9	32.4
KGF-N-3260-P10-3,5 RH-EE	E	53	68	7	80	16	68	10	16	8	8	M 6	0,08	4,8	–	20	49,3
KGF-N 4005 RH-EE	E	53	68	7	80	10	59	–	16	8	8	M 6	0.08	5	26.0	23.8	63.1
KGF-N 4010 RH-EE	E	63	78	9	95	10	73	–	16	8	8	M 8x1	0.08	3	50.0	38.0	69.1
KGF-N 5010 RH-EE	E	72	90	11	110	10	97	–	18	8	9	M 8x1	0.08	5	78.0	68.7	155.8
KGF-N 6310 RH-EE	E	85	105	11	125	10	99	–	20	8	10	M 8x1	0.08	5	86.0	76.0	197.0
KGF-N 8010 RH-EE	E	105	125	13.5	145	10	101	–	22	8	11.5	M 8x1	0.08	5	-	82.7	221.9

¹⁾ Dynamic load rating according to DIN 69051 part 4 draft 1978.

²⁾ Dynamic load rating according to DIN 69051 part 4 draft 1989.

Cylindrical ball nuts

KGM-D

according to DIN 69051

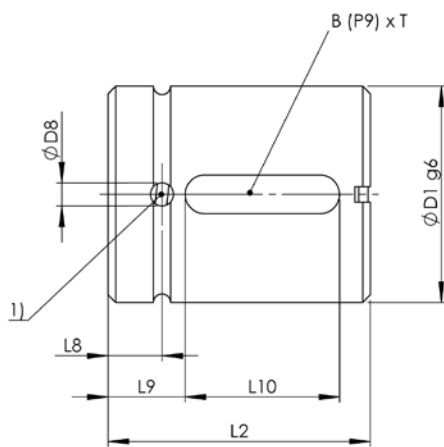

Form E

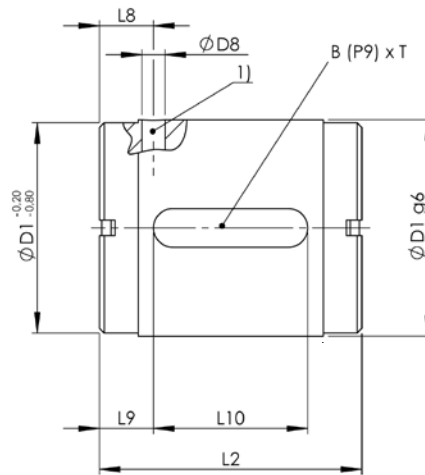

Form S

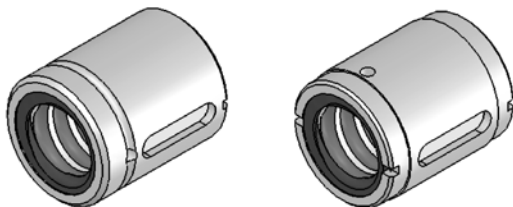

¹⁾ Position of the lubrication bore not defined

Material: 1.7131 (ESP65) or 1.3505 (100 Cr 6)

Type Diameter [mm] Pitch [mm] Right-hand thread	Form	Dimensions [mm]							Axial backlash max [mm]	No. of circuits	Load rating [kN]		
		D_1	D_8	L_2	L_8	L_9	L_{10}	BxT			$C^{2)}$	$C^{3)}$	$C_o = C_{oa}$
KGM-D 1605 RH-EE	E	28	3	34	7	7	20	5x2	0,08	3	12,5	9,3	13,1
KGM-D 1610 RH-EE	E	28	3	50	7	15	20	5x2,2	0,08	6	23,0	15,4	26,5
KGM-D-1616-P8	E	28	3	45	7	12,5	20	5x2,2	0,08	3,75	–	10	16,4
KGM-D 1640-P10-3 RH-EE	E	28	1,5	45	14,5	17,5	10	5x2	0,08	4	–	8,5	13
KGM-D 2005 RH-EE	E	36	3	34	7	7	20	5x2	0,08	3	14,0	10,5	16,6
KGM-D 2505 RH-EE	E	40	3	34	7	7	20	5x2	0,08	3	15,0	12,3	22,5
KGM-D 2510 RH-EE	E	40	3	45	7,5	12,5	20	5x2	0,08	3	17,5	13,2	25,3
KGM-D 2520 RH-EE	S	40	1,5	35	14	11,5	12	5x3	0,15	4	19,0	13,0	23,3
KGM-D 2525 RH-EE	S	40	1,5	35	11,5	11	13	5x3	0,08	5	21,0	16,7	32,2
KGM-D 2550 RH-EE	S	40	1,5	58	17	19	20	5x3	0,15	5	22,5	15,4	31,7
KGM-D 3205 RH-EE	E	50	3	45	7,5	8	30	6x2,5	0,08	5	24,0	21,5	49,3
KGM-D 4005 RH-EE	E	63	3	45	7,5	8	30	6x2,5	0,08	5	26,0	23,8	63,1
KGM-D 4010 RH-EE	E	63	4	60	10	15	30	6x2,5	0,08	3	50,0	38,0	69,1
KGM-D 4020 RH-EE	E	63	3	70	7,5	20	30	6x2,5	0,08	4	44,5	33,3	76,1
KGM-D 4040 RH-EE	S	63	1,5	85	15	27,5	30	6x3,5	0,08	8	42,0	35,0	101,9
KGM-D 5010 RH-EE	E	75	4	82	11	23	36	6x2,5	0,08	5	78,0	68,7	155,8
KGM-D 6310 RH-EE	E	90	4	82	11	23	36	6x2,5	0,08	5	86,0	76,0	197,0
Left-hand thread													
KGM-D 2005 LH-EE	E	36	3	34	7	7	20	5x2	0,08	3	16,5	10,5	16,6

¹⁾ Position of the lubrication bore not defined.

²⁾ Dynamic load rating according to DIN 69051 part 4 draft 1978.

³⁾ Dynamic load rating according to DIN 69051 part 4 draft 1989.

Cylindrical ball nuts KGM-N

according to NEFF standard

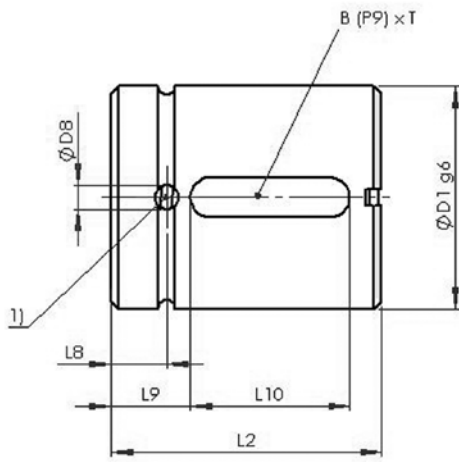

Form E

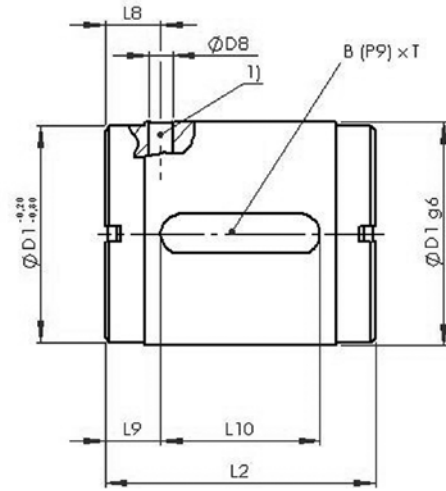

Form S

¹⁾ Position of the lubrication bore not defined

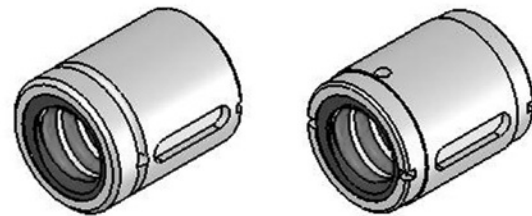

Material: 1.7131 (ESP65) or 1.3505 (100 Cr 6)

Type Diameter [mm] Pitch [mm] Right-hand thread	Form	Dimensions [mm]							Axial backlash max [mm]	No. of circuits	Load rating [kN]		
		D_1	D_8	L_2	L_8	L_9	L_{10}	BxT			$C^{(2)}$	$C^{(3)}$	$C_0 = C_{0a}$
KGM-N 1205 RH-00	E	20 ⁴⁾	–	24	–	5	14	3x1.8	0.08	3	6.0	4.4	6.8
KGM-N 2005 RH-EE	E	32	3	34	7	7	20	5x2	0.08	3	14.0	10.5	16.6
KGM-N 2020 RH-EE	S	35	1.5	30	11.5	9	12	5x3	0.08	4	12.0	11.6	18.4
KGM-N 2050 RH-EE	S	35	1.5	56	16	18	20	5x2.2	0.15	5	18.0	13.0	24.6
KGM-N 2505 RH-EE	E	38	3	34	7	7	20	5x2	0.08	3	15.0	12.3	22.5
KGM-N 3205 RH-EE	E	45	3	45	7.5	8	30	6x2.5	0.08	5	24.0	21.5	49.3
KGM-N 3210 RH-EE	E	53	4	60	10	15	30	6x2.5	0.08	3	44.0	33.4	54.5
KGM-N 3220 RH-EE	E	53	3	70	7.5	20	30	6x2.5	0.08	4	42.5	29.7	59.8
KGM-N 3240 RH-EE	S	53 ⁵⁾	1.5	45	13	10	25	6x4	0.08	4	17.0	14.9	32.4
KGM-N-3260-P10-3,5 RH-EE	S	53	1,5	68	15,5	21,5	25	6x2,5	0,08	4,8	–	19,8	46,6
KGM-N 4005 RH-EE	E	53	3	45	7.5	8	30	6x2.5	0.08	5	26.0	23.8	63.1
KGM-N 5010 RH-EE	E	72	4	82	11	23	36	6x2.5	0.08	5	78.0	68.7	155.8
KGM-N 5020 RH-EE	E	85	4	82	10	23	36	6x2.5	0.08	4	82.0	60.0	136.3
KGM-N 6310 RH-EE	E	85	4	82	11	23	36	6x2.5	0.08	5	86.0	76.0	197.0
KGM-N 8010 RH-EE	E	105	4	82	11	23	36	8x3	0.08	5	-	82.7	221.9

¹⁾ Position of the lubrication bore not defined.

²⁾ Dynamic load rating according to DIN 69051 part 4 draft 1978.

³⁾ Dynamic load rating according to DIN 69051 part 4 draft 1989.

⁴⁾ Nut without wiper.

⁵⁾ $D_1 -0,2/-0,8$ does not apply, therefore $D_1 -1,0/-1,5$.

Ball nuts KGM-E

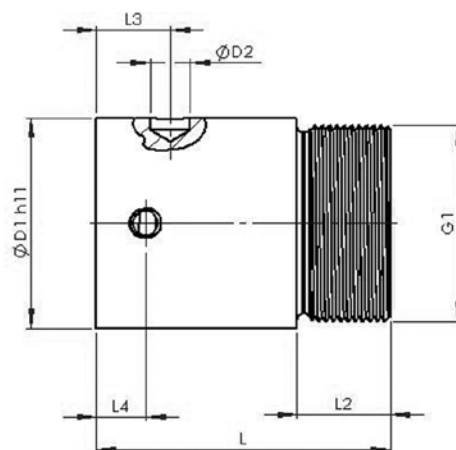
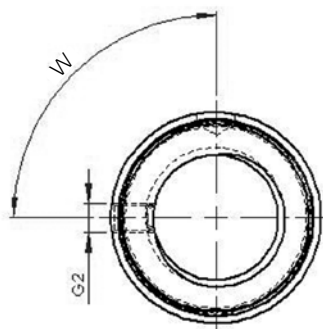

Material: 1.7131 (ESP65) or 1.3505 (100 Cr 6)

Size	Dimensions [mm]								
	D1h11	D2	L	L2	L3	L4	G1	G2	W
KGM-E-1605-RH	32	3.2	42	12	3		M26x1.5		
KGM-E-2005-RH	38	8	45	14	8	8	M35x1.5	M6	90°
KGM-E-2505-RH	43	8	60	19	15	10	M40x1.5	M6	90°
KGM-E-2510-RH	43	8	74	19	16	16	M40x1.5	M6	180°
KGM-E-3205-RH	52	8	63	19	15	10	M48x1.5	M6	90°
KGM-E-3210-RH	54	8	78	19	8	8	M48x1.5	M6	90°
KGM-E-4005-RH	60	8	63	19	15	10	M56x1.5	M8x1	90°
KGM-E-4010-RH	65	8	84	24	15	8	M60x2	M8x1	90°
KGM-E-5010-RH	78	8	111	29	15	8	M72x2	M8x1	90°

Ordering code for ball nuts

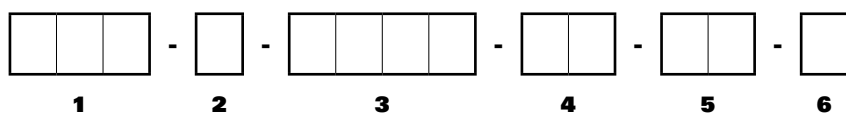

No.	Designation	Code	Description
1	Product abbreviation	KGF	Flanged ball nuts
		KGM	Cylindrical ball nuts
2	Nut version	D	Nut according to DIN 69051 standard
		N	Nut according to NEFF standard
		E	Nut with screw-in thread
		S	Nut with special dimensions
3	Thread designation		e.g. 2005 (diameter 20 mm, pitch 5mm)
4	Pitch direction	RH	Right-hand thread
		LH	Left-hand thread
5	Seal	0	without wiper
		EE	with double-sided wiper
6	Special requirements	0	None
		1	According to specification, description or drawing

Ordering code

Ball screw

Ordering code for ball screw

1	2	3	4	5	6	7	8	9	10	11	12	

No.	Designation	Code	Description
1	Product abbreviation	KGT	Ball screw
2	Spindle abbreviation	R	Rolled
		W	Spun
		S	Grounded
3	Spindle designation		e.g. 2005 (diameter 20 mm, pitch 5 mm)
4	Accuracy class of the spindle	T5	23µ/300 mm
		T7	50µ/300 mm
		T9	130µ/300 mm
		T10	200µ/300 mm
5	Pitch direction	RH	Right-hand thread
		LH	Left-hand thread
6	Spindle end A	O A GA GB K D F H J L S T W Fk FF BK BF M AS RS VS Z	Ends only sawn and brushed
7	Spindle end B		End with chamfer
			1st end annealed (indicate length in the additional text)
			2nd end annealed (indicate length in the additional text)
			End according to customer drawing or project drawing no.
			End fixed bearing form D for bearing ZKLF
			End fixed bearing form F for bearing ZARN
			End fixed bearing form H for bearing ZARF/LTN
			End fixed bearing form J for bearing FDX 12-40
			End fixed bearing form L for bearing 7201-7208
			End movable bearing form S for bearing 6001-6211
			End movable bearing form T for needle bearing HK1614-4518
			End movable bearing form W for bearing 6001-6211
		End fixed bearing unit FK4-FK30	
		End movable bearing unit FF6-FF30	
		End fixed bearing unit BK10-BK40	
		End movable bearing unit BF10-BF40	
		Metric threaded stem SHG	
		End hollowing safeguard SHG	
		End worm gear connection rotary spindle SHG	
		End anti-twist device SHG	
		cylindrical bearing journal SHG with rotary spindle	
8	Overall length in (mm)		e.g. 1000
9	Special requirements spindle	0	none
		1	According to specification, description or drawing
10	Ball nut or nut unit with installation note	M	Single nut, cylindrical
		MM	Nut unit, cylindrical, pre-loaded
		FO	Flanged single nut (flange to fixed bearing or longer end)
		OF	Flanged single nut (flange to movable bearing or shorter end)
		FM	Nut unit flanged nut + cylinder nut (flange to fixed bearing or longer end)
		MF	Nut unit flanged nut + cylinder nut (flange to movable bearing or shorter end)
		FF	Nut unit flanged nut + flanged nut
		EO	Single nut with screw-in thread (thread to fixed bearing or longer end)
11	Nut version	OE	Single nut with screw-in thread (thread to movable bearing or shorter end)
		D	Nut with DIN 69051 dimensions
		N	Nut with Neff dimensions
12	Special requirements for nut	S	Nut with special dimensions (according to drawing)
		0	none
		1	According to specification, description or drawing

Calculation

Ball screw Drive

Required drive torque and drive power

The required drive moment of a screw drive results from the acting axial load, the thread pitch and the efficiency of the screw drive and its bearing. In case of short acceleration times and high speeds the acceleration torque must be checked.

Fundamentally it must be noted that trapezoidal screw drives have to overcome a breakaway torque when starting up.

Required drive torque

(XV)

$$M_d = \frac{F_{ax} \cdot P}{2000 \cdot \pi \cdot \eta_A} = + M_{rot}$$

F_{ax}	Total acting axial force [N]
P	Thread pitch [mm]
η_A	Efficiency of the complete drive $= \eta_{KGT} \cdot \eta_{Ball \text{ screw drive}} \cdot \eta_{Fixed \text{ bearing}}$ $\eta_{KGT} (\mu = 0.1)$ $= 0.9 \dots 0.95$ $\eta_{Movable \text{ flange}} = 0.95$
M_d	Required drive torque [Nm]
M_{rot}	Rotary acceleration torque [Nm] $= J_{rot} \cdot \alpha_0$ $= 7.7 \cdot d^4 \cdot L \cdot 10^{-13}$
J_{rot}	Rotary moment of inertia [kgm ²]
d	Nominal spindle diameter [mm]
L	Spindle length [mm]
α_0	Angular acceleration [1/s ²]

Drive power

(XVII)

$$P_a = \frac{M_d \cdot n}{9550}$$

M_d	Required drive torque [Nm]
n	Spindle speed [1/min]
P_a	Required drive power [kW]

Calculation

Ball screw Drive

Service life L

The (nominal) service life of a ball screw is calculated in the same way as the service life of a ball bearing.

Average speed

(I)

$$n_m = \frac{n_1 \cdot q_1 + n_2 \cdot q_2 + \dots + n_i \cdot q_i}{100}$$

Dynamic equivalent axial load (II)

$$F_m = \sqrt[3]{F_1^3 \cdot \frac{n_1 \cdot q_1}{n_m \cdot 100} + F_2^3 \cdot \frac{n_2 \cdot q_2}{n_m \cdot 100} + \dots + F_i^3 \cdot \frac{n_i \cdot q_i}{n_m \cdot 100}}$$

Service life of the ball screw (III)

in rollovers

$$L_{10} = \left(\frac{C}{F_m} \right)^3 \cdot 10^6$$

in hours

$$L_h = \frac{L_{10}}{n_m \cdot 60}$$

Calculation of the average force F_m

Similar to the single nut

Service life L

(IV)

$$L = \left(F_{m1}^{\frac{10}{3}} + F_{m2}^{\frac{10}{3}} \right)^{-0.9} \cdot C^3 \cdot 10^6$$

The calculation methods are only valid under perfect lubrication conditions. The service life can be reduced considerably in case of dirt or a lack of lubricant. Also, a shortening of the service life is to be expected with very short strokes. In these cases please consult our product advisors.

Caution!

Ball screws can absorb neither radial forces nor pull-out torques

Caution!

Note that vibrations and impact loads can negatively affect the service life of the ball screw

n_1, n_2, \dots Speeds in [rpm] during the interval q_1, q_2, \dots

n_m Average speed in [1/min]

q_1, q_2, \dots Percentage of the loading period in one load direction in [%]

F_1, F_2, \dots Axial loads in [N] in one load direction during the interval q_1, q_2, \dots

F_m Dynamic equivalent axial load

Since a ball screw can be loaded in two directions, F_m must initially be determined for each of the two load directions. The larger value is then taken for the calculation of L.

In general it is useful to prepare a diagram. In doing so, remember that any pre-loading represents a constant load.

C Axial, dynamic load rating

Centrally acting load in [N] of a constant size and direction, with which a sufficient large number of identical ball screws achieved a service life of 106 revolutions.

L_{10}

Service life of the ball screw, expressed in the number of rollovers achieved by 90% (L_{10}) of a sufficiently large number of obviously identical ball screws before the first signs of material fatigue appear.

Service life of a ball screw with a pre-loaded nut system

The pre-loading force of the nut unit acts as constant load on the ball screw.

F_{m1}, F_{m2}, \dots Dynamic equivalent axial load of the first or second nut respectively [N].

C Axial, dynamic load rating

Centrally acting load in [N] of a constant size and direction, with which a sufficient large number of identical ball screws achieved a service life of 106 revolutions.

Calculation

Ball screw

Example calculation

Lifetime of a ball screw

Given:

$F_1 = 30000 \text{ N}$ at $n_1 = 150 \text{ 1/min}$ for $q_1 = 21 \%$ of the duration of operation

$F_2 = 18000 \text{ N}$ at $n_2 = 1000 \text{ 1/min}$ for $q_2 = 13 \%$ of the duration of operation

$F_3 = 42000 \text{ N}$ at $n_3 = 75 \text{ 1/min}$ for $q_3 = 52 \%$ of the duration of operation

$F_4 = 1800 \text{ N}$ at $n_4 = 2500 \text{ 1/min}$ for $q_4 = 14 \%$ of the duration of operation

$$\Sigma = 100 \%$$

Required:

Maximum attainable service life under the given switch-on conditions.

Ball screw KGT 5010

Average spindle speed n_m from (I)

$$n_m = \frac{n_1 \cdot q_1 + n_2 \cdot q_2 + n_3 \cdot q_3 + n_4 \cdot q_4}{100}$$

$$n_m = \frac{150 \cdot 21 + 1000 \cdot 13 + 75 \cdot 52 + 2500 \cdot 14}{100} \text{ 1/min}$$

$$\rightarrow n_m = 550.5 \text{ 1/min}$$

Dynamic equivalent axial load F_m from (II)

$$F_m = \sqrt[3]{F_1^3 \cdot \frac{n_1 \cdot q_1}{n_m \cdot 100} + F_2^3 \cdot \frac{n_2 \cdot q_2}{n_m \cdot 100} + F_3^3 \cdot \frac{n_3 \cdot q_3}{n_m \cdot 100} + F_4^3 \cdot \frac{n_4 \cdot q_4}{n_m \cdot 100}}$$

$$F_m = \sqrt[3]{30000^3 \cdot \frac{150 \cdot 21}{550.5 \cdot 100} + 18000^3 \cdot \frac{1000 \cdot 13}{550.5 \cdot 100} + 42000^3 \cdot \frac{75 \cdot 52}{550.5 \cdot 100} + 1800^3 \cdot \frac{2500 \cdot 14}{550.5 \cdot 100}} \text{ N}$$

$$F_m = 18943 \text{ N}$$

Service life of the ball screw L_{10} from (III)

$$L_{10} = \left(\frac{C}{F_m} \right)^3 \cdot 10^6$$

Dynamic load rating $C = 68700 \text{ N}$

$$L_{10} = \left(\frac{68700}{18943} \right)^3 \cdot 10^6$$

Number of rollovers L_{10}

$$L_{10} = 47,7 \cdot 10^6$$

$$L_h = \frac{L_{10}}{n_m \cdot 60} = \frac{47,7 \cdot 10^6}{550.5 \cdot 60} = 1444 \text{ h}$$

Service life in hours L_h

Result Under the given loads the selected screw drive has a total service life of $47,7 \cdot 10^6$ rollovers, which corresponds to a timespan of 1444 hrs.

Calculation

Ball screw

Types of bearing

Typical values for the correction factor f_k according to the classic installation cases for standard spindle bearings.

Neff bearing case I

Fixed bearing – loose end, correction factor $f_k=0.25 / f_{kr}=0.43$

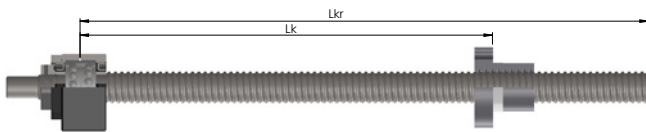

Neff bearing case II

Movable bearing – movable bearing, correction factor $f_k=1 / f_{kr}=1.21$

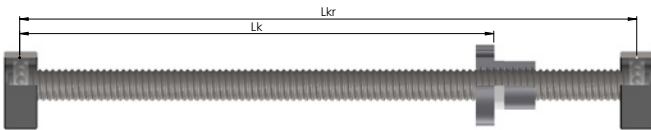

Neff bearing case III

Fixed bearing – movable bearing, correction factor $f_k=2.05 / f_{kr}=1.89$

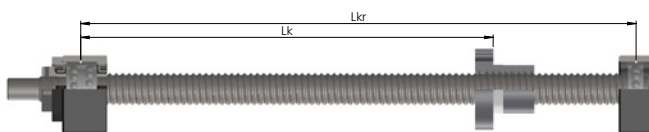

Neff bearing case IV

Fixed bearing – fixed bearing, correction factor $f_k=4 / f_{kr}=2.74$

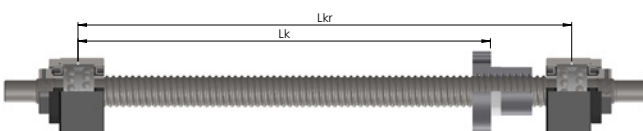

Critical buckling force of ball screws

With slim components such as spindles there is a danger of lateral buckling under axial compressive loads. Using the procedure described below, the permissible, axial force can be determined according to Euler. The safety factors applying to the system must be considered before determining the permissible compressive force.

Theoretically critical buckling force in [kN]:

$$F_k = \left(\frac{d_2}{L_k} \right)^4 \cdot 10^5 : 1000$$

Maximum permissible axial force in:

$$F_{zul} = F_k \cdot f_k \cdot \frac{1}{S_f}$$

F_{zul}	Maximum permissible axial force [kN]
F_k	Theoretically critical buckling force [kN]
f_k	Correction factor that takes into account the type of spindle bearing
d_2	Core diameter of the spindle [mm]
L_k	Unsupported length on which the force acts on the spindle [mm]
S_f	Safety factor (specified by the user)

Caution!

The operating force must not exceed 80% of the maximum permissible axial force

Critical speed of ball screws

With slim, rotating components such as spindles there is a risk of resonant vibration. The procedure described below enables the resonant frequency to be estimated, assuming an adequately rigid installation. In addition, speeds close to the critical speed greatly increase the risk of lateral buckling. The critical speed must therefore also be considered in connection with the critical buckling force.

Theoretically critical speed in [rpm]

$$F_{kr} = \left(\frac{d_2}{L_{kr}} \right)^2 \cdot 10^8$$

n_{zul}	Maximum permissible spindle speed [1/min]
n_{kr}	Theoretically critical spindle speed [rpm] that leads to resonant vibrations
f_{kr}	Correction factor that takes into account the type of spindle bearing
d_2	Core diameter of the spindle [mm]
L_{kr}	unsupported spindle length [mm]

Caution!

The operating force must not exceed 80% of the maximum permissible axial force

Maximum permissible speed of rotation in [rpm]

$$f_{kr} = F_{kr} \cdot f_k \cdot 0,8$$

Calculation

Ball screw

Theoretically permissible buckling force:

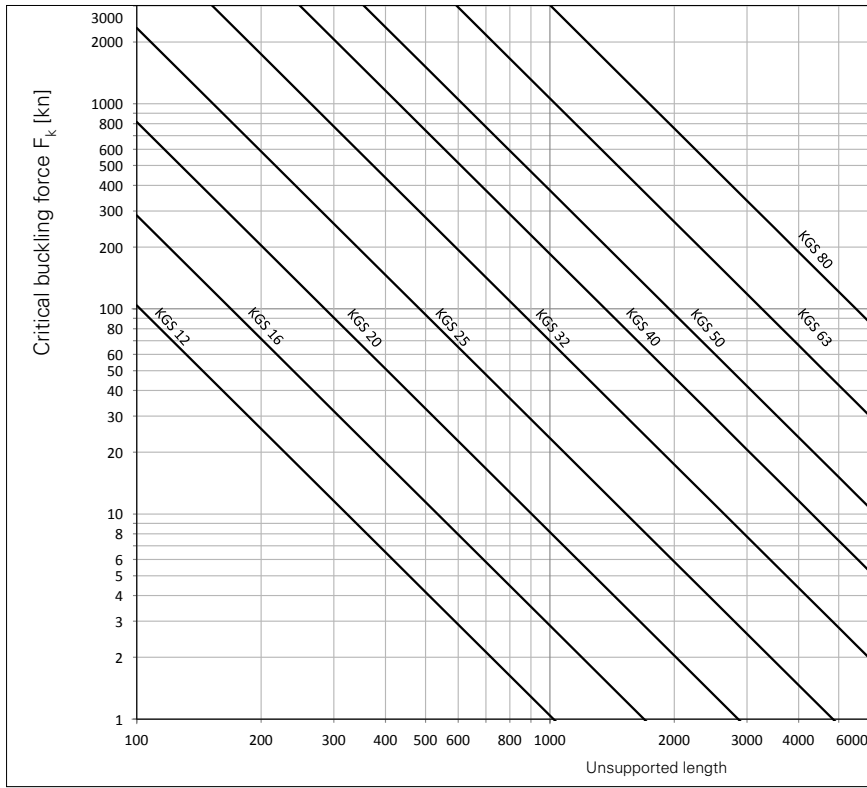

Theoretically permissible speed:

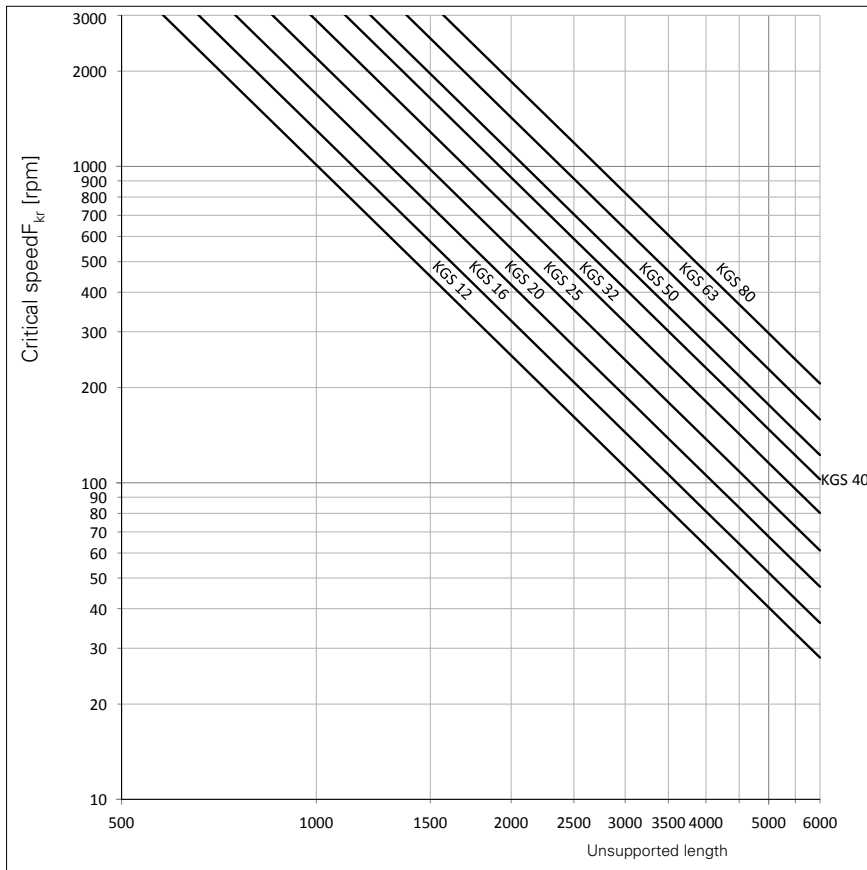

General technical data

Trapezoidal-threaded spindles

Trapezoidal-threaded spindles from Neff Gewindetriebe are manufactured by rolling according to DIN 103. Thanks to the non-cutting cold forming, the grain is not interrupted; the surface of the thread is compacted and burnished.

Advantages of rolled trapezoidal-threaded spindles:

- Improved tensile strength
- Higher resistance to wear
- High dimensional accuracy
- Improved bending strength

Areas of application:

Rolled trapezoidal-threaded spindles can be used wherever an inexpensive solution is required for the transformation of rotary motion into translatory motion, even under harsh environmental conditions.

Precision trapezoidal-threaded spindle RPTS

	Thread	Ø	Pitch	Number of starts	Direction of rotation	Length	Material	Weldability	Accuracy	Straightness	Surface
Standard	Metric ISO trapezoidal thread according to DIN 103-7e	10-80 mm	2-24 mm	Up to 6 starts	right-handed, single-start also left-handed	3000 mm up to Tr 18x4, 6000 mm from Tr 20x6	1.0401 bright steel C15, stress-relieved, glow	very easily weldable	50-300 µm/300mm	0,1-0,5 mm/300 mm	Burnished
Stainless	Metric ISO trapezoidal thread according to DIN 103-7e (1)	18-40 mm	4-7 mm	single-start	right and left-handed	3000 mm up to Tr 20x4, 6000 mm from Tr 30x6	1.4305 X8Cr-NiS18-9, austenite and corrosion resistant bright steel	conditionally weldable	50-300 µm/300mm	0,1-0,5 mm/300 mm	Burnished
Manganese-phosphated	Metric ISO trapezoidal thread according to DIN 103-7e (1)	10-80 mm	2-24 mm	Up to 6 starts	right-handed, single-start also left-handed	3000 mm up to Tr 18x4, 6000 mm from Tr 20x6	1.0401 bright steel C15, stress-relieved, glow, weldable, manganic phosphate-treated	very easily weldable	50-300 µm/300mm	0,1-0,5 mm/300 mm	Crystalline phosphate surface

Trapezoidal-threaded nuts

Typ	TGM-SKM	TGM-KSM	TGM-LRM	TGM-EFM	TGM-SFM	TGM-LKM
Thread	DIN 103-7H	DIN 103-7H	DIN 103-7H	DIN 103-7H	DIN 103-7H	DIN 103-7H
Nominal DM	10-70 mm	10-80 mm	10-80 mm	12-80 mm	12-80 mm	12-50 mm
Pitch	2-10 mm	2-10mm	2-10mm	3-10 mm	3-10 mm	3-8 mm
Number of threads	single-start	single-start	single or multi-start	single or multi-start	single or multi-start	single or multi-start
Thread direction	Right or left-hand thread	Right or left-hand thread	Right or left-hand thread	Right or left-hand thread	Right or left-hand thread	Right or left-hand thread
Material	1.0718 (9SMn 28K)	1.0718 (9SMn 28K)	2.1090 (G-CuSn7ZnPb)	2.1090 (G-CuSn7ZnPb)	2.1090 (G-CuSn7ZnPb)	PETP
Suitable for	Clamping processes, adjustment movements in manual operation	Clamping processes, adjustment movements in manual operation	Low and medium-speed movement drives	Movement drives with particularly favourable wear characteristics	Safety-relevant movement drives with particularly favourable wear characteristics	For low-noise movement drives with higher speed and duty cycle

General technical data

Trapezoidal-threaded spindles

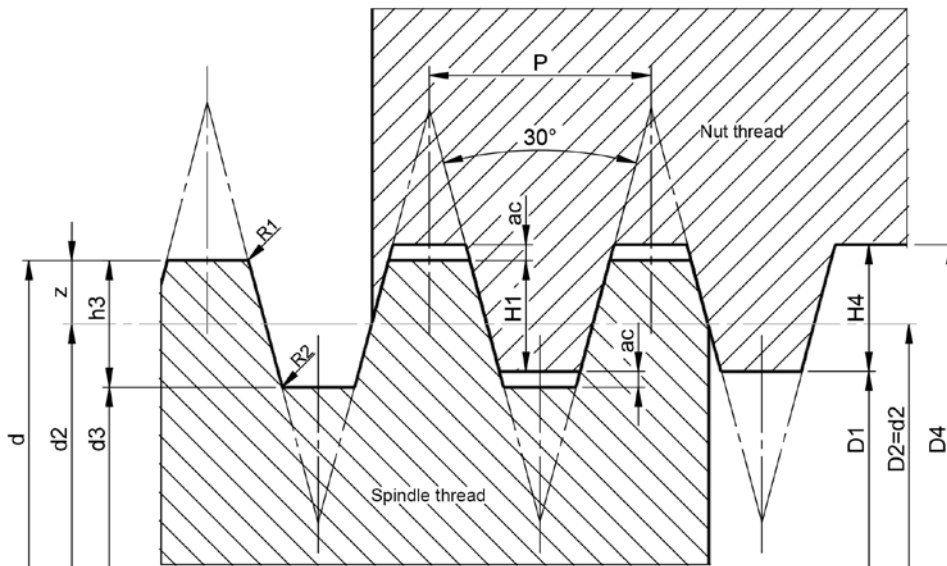

$$D_1 = d - 2H_1 = d - P$$

$$H_1 = 0.5P$$

$$H_4 = H_1 + a_c = 0.5P + a_c$$

$$h_3 = H_1 + a_c = 0.5P + a_c$$

$$z = 0.25P = H_1/2$$

$$D_4 = d + 2a_c$$

$$d_3 = d - 2h_3 \text{ (due to the rolling process max. } 0.15 \times P \text{ smaller sized)}$$

$$d_2 = D_2 = d - 2z = d - 0.5P$$

$$a_c = \text{backlash}$$

$$R_1 = \text{max. } 0.5$$

$$R_2 = \text{max. } a_c \text{ (is omitted with rolled spindles and replaced by } 0.15 \times P/2 = \text{flow radius)}$$

Dimensions for thread profile

P	$a_c^{(1)}$	$R_{1 \text{ max.}}$	$R_{2 \text{ max.}}^{(2)}$
1.5	0.15	0.075	0.2625
2	0.25	0.125	0.4
3	0.25	0.125	0.475
4	0.25	0.125	0.55
5	0.25	0.125	0.625
6	0.5	0.25	0.95
7	0.5	0.25	1.025
8	0.5	0.25	1.1
9	0.5	0.25	1.175
10	0.5	0.25	1.25

Profiles for multi-start threads:

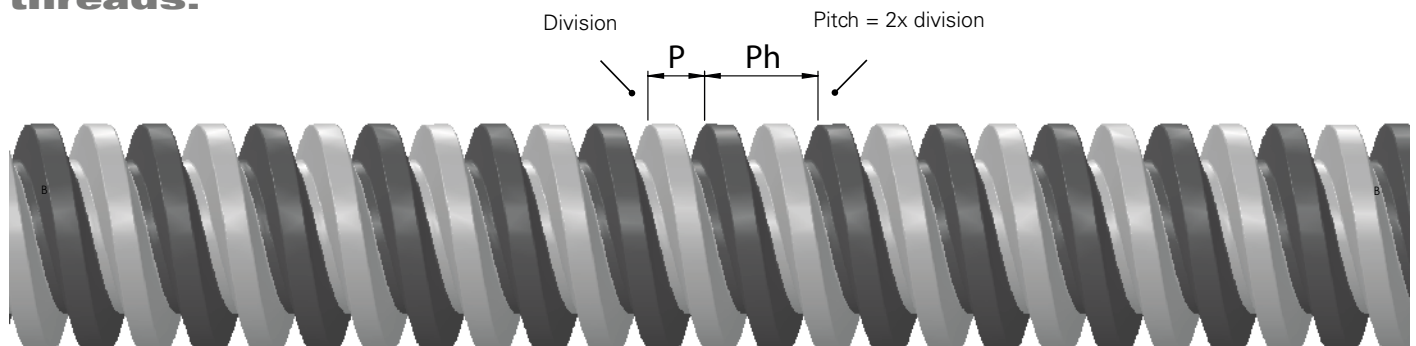

Multi-start threads have the same profile as single-start threads with the pitch $P_h = \text{division } P$.

$P_h = \text{pitch}$:
Distance along the effective pitch diameter line between neighbouring flanks in the same direction of the same thread pitch.

$P = \text{division}$:
Distance along the effective pitch diameter line between neighbouring flanks in the same direction.

Trapezoidal-threaded spindles RATS

Rolled precision trapezoidal-threaded spindle RATS made of case-hardened steel C15

Material: 1.4305 (X8CrNiS18-9)

Tolerance class: 7e

Manufacturing length: 3000mm up to \varnothing 20mm, 6000mm from \varnothing 20mm

Excess lengths: up to 12000 mm on enquiry

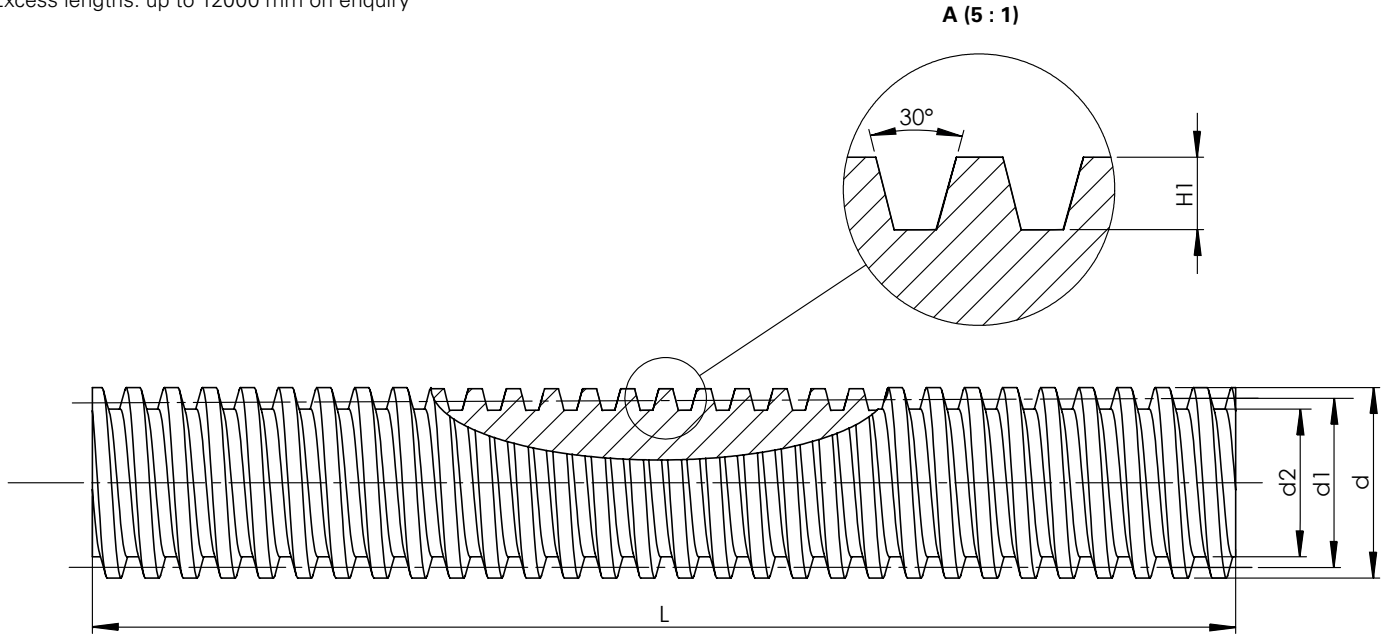

Type Outside diameter [mm] Pitch [mm] right/left-handed	d	Dimension [mm]				Accuracy [μ m/300 mm]	Straightness [mm/300 mm]	Pitch angle (2.1. 2.2. 2.3)	Efficiency ⁽³⁾	Linear load [kg/m]	Geometrical moment of inertia [cm ⁴]	Resistive torque [cm ³]	Mass moment of inertia [kg m ² /m]
		$d_{1 \min}$	$d_{1 \max}$	d_2	$H_1^{(1)}$			α					
RATS Tr 18x4	18	15.640	15.905	12.80	2	50	0.1	4° 32'	0.43	1.58	0.132	0.206	$5.05 \cdot 10^{-5}$
RATS Tr 18x8 P4	18	15.640	15.905	12.80	2	50	0.2	9° 14'	0.43	1.58	0.132	0.206	$5.05 \cdot 10^{-5}$
RATS Tr 20x4	20	17.640	17.905	14.80	2	50	0.1	4° 2'	0.40	2.00	0.236	0.318	$8.10 \cdot 10^{-5}$
RATS Tr 24x5	24	21.094	21.394	17.50	2.5	50	0.1	4° 14'	0.41	2.85	0.460	0.526	$1.65 \cdot 10^{-4}$
RATS Tr 30x6	30	26.547	26.882	21.90	3	50	0.1	4° 2'	0.40	4.50	1.130	1.030	$4.10 \cdot 10^{-4}$
RATS Tr 36x6	36	32.547	32.882	27.90	3	50	0.1	3° 18'	0.35	6.71	2.970	2.130	$9.10 \cdot 10^{-4}$
RATS Tr 40x7	40	36.020	36.375	30.50	3.5	50	0.1	3° 29'	0.37	8.21	4.250	2.790	$1.37 \cdot 10^{-3}$

(1) Thread depth of the basic profile according to DIN 103

(2.1) Self-locking from the movement < 2.4°

(2.2) Self-locking from the fill level > 2.4° < 4.5°

(2.3) No self-locking > 4.5°

(3) Efficiency, calculated with friction value 0.1

Trapezoidal screw spindles RPTS

Rolled precision trapezoidal-threaded spindles RPTS made of case-hardened steel C15

Material: 1.0401 (C15)

Tolerance class: 7e

Manufacturing length: 3000mm up to \varnothing 20mm, 6000mm from \varnothing 20mm

Excess lengths: up to 12000 mm on enquiry

A (5 : 1)

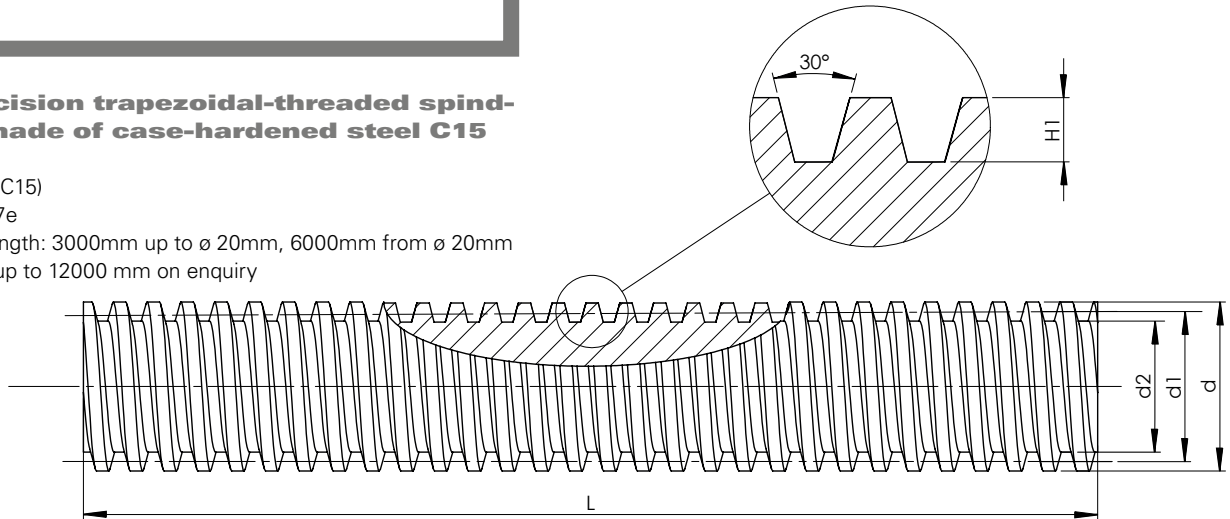

Type Outside diameter [mm] Pitch [mm] right/left-handed	d	Dimension [mm]				Accuracy [μ m/ 300 mm]	Straight- ness [mm/ 300 mm]	Pitch angle (2.1, 2.2, 2.3) α	Efficiency ⁽³⁾ η	Linear load [kg/m]	Geometrical moment of inertia [cm ⁴]	Resistive torque [cm ³]	Mass moment of inertia [kg m ² /m]
		d _{1 min}	d _{1 max}	d ₂	H ₁ ⁽¹⁾								
RPTS Tr 10x2	10	8.739	8.929	6.89	1	300	0.5	4° 2'	0.40	0.500	0.011	0.032	0.51 · 10 ⁻⁵
RPTS Tr 10x3		8.191	8.415	5.84	1.5	300	0.5	6° 24'	0.51	0.446	0.0057	0.020	0.40 · 10 ⁻⁵
RPTS Tr 12x3	12	10.191	10.415	7.84	1.5	300	0.5	5° 11'	0.46	0.68	0.019	0.047	0.94 · 10 ⁻⁵
RPTS Tr 12x6 P3	12	10.165	10.415	7.84	1.5	300	0.5	10° 18'	0.62	0.68	0.019	0.047	0.94 · 10 ⁻⁵
RPTS Tr 14x3	14	12.191	12.415	9.84	1.5	300	0.5	4° 22'	0.42	0.96	0.046	0.094	1.88 · 15 ⁻⁵
RPTS Tr 14x4		11.640	11.905	8.80	2	300	0.5	6° 3'	0.50	0.888	0.029	0.067	1.60 · 10 ⁻⁵
RPTS Tr 16x2	16	14.729	14.929	12.89	1	50	0.1	2° 36'	0.28	1.39	1.36	0.21	3.9 · 10 ⁻⁵
RPTS Tr 16x4	16	13.640	13.905	10.80	2	50	0.1	5° 11'	0.46	1.21	0.067	0.124	2.96 · 10 ⁻⁵
RPTS Tr 16x8 P4	16	13.608	13.905	10.80	2	300	0.3	10° 18'	0.62	1.21	0.067	0.124	2.96 · 10 ⁻⁵
RPTS Tr 18x4	18	15.640	15.905	12.80	2	50	0.1	4° 32'	0.43	1.58	0.132	0.206	5.05 · 10 ⁻⁵
RPTS Tr 18x8 P4	18	15.640	15.905	12.80	2	50	0.2	9° 14'	0.43	1.58	0.132	0.206	5.05 · 10 ⁻⁵
RPTS Tr 20x4	20	17.640	17.905	14.80	2	50	0.1	4° 2'	0.40	2.00	0.236	0.318	8.10 · 10 ⁻⁵
RPTS Tr 20x8 P4		17.608	17.905	14.80	2	200	0.2	8° 3'	0.57	2.00	0.236	0.318	8.10 · 10 ⁻⁵
RPTS Tr 20x16 P4		17.608	17.905	14.80	2	200	0.2	15° 47'	0.71	2.00	0.236	0.318	8.10 · 10 ⁻⁵
RPTS Tr 22x5	22	19.114	19.394	15.50	2.5	50	0.1	4° 39'	0.43	2.34	0.283	0.366	1.11 · 10 ⁻⁴
RPTS Tr 22x24 P4 S		19.140	19.505	16.50	2.5	200	0.2	21° 34'	0.75	2.34	0.364	0.441	1.11 · 10 ⁻⁴
RPTS Tr 24x5	24	21.094	21.394	17.50	2.5	50	0.1	4° 14'	0.41	2.85	0.460	0.526	1.65 · 10 ⁻⁴
RPTS Tr 24x10 P5		21.058	21.394	17.50	2.5	200	0.2	8° 25'	0.58	2.85	0.460	0.526	1.65 · 10 ⁻⁴
RPTS Tr 26x5	26	23.094	23.394	19.50	2.5	50	0.1	3° 52'	0.39	3.40	0.710	0.728	2.35 · 10 ⁻⁴
RPTS Tr 28x5	28	25.094	25.394	21.50	2.5	50	0.1	3° 34'	0.37	4.01	1.050	0.976	3.26 · 10 ⁻⁴
RPTS Tr 30x6	30	26.547	26.882	21.90	3	50	0.1	4° 2'	0.40	4.50	1.130	1.030	4.10 · 10 ⁻⁴
RPTS Tr 30x12 P6		26.507	26.882	21.90	3	200	0.2	8° 3'	0.57	4.50	1.130	1.030	4.10 · 10 ⁻⁴
RPTS Tr 32x6	32	28.547	28.882	23.90	3	50	0.1	3° 46'	0.38	5.19	1.600	1.340	5.45 · 10 ⁻⁴
RPTS Tr 36x6	36	32.547	32.882	27.90	3	50	0.1	3° 18'	0.35	6.71	2.970	2.130	9.10 · 10 ⁻⁴
RPTS Tr 36x12 P6	36	32.547	32.882	27.90	3	50	0.1	6° 41'	0.35	6.71	2.970	2.130	9.10 · 10 ⁻⁴
RPTS Tr 40x7	40	36.020	36.375	30.50	3.5	50	0.1	3° 29'	0.37	8.21	4.250	2.790	1.37 · 10 ⁻³
RPTS Tr 40x14 P7		35.978	36.375	30.50	3.5	200	0.2	6° 57'	0.53	8.21	4.250	2.790	1.37 · 10 ⁻³
RPTS Tr 44x7	44	40.020	40.275	34.50	3.5	50	0.1	3° 8'	0.34	10.10	6.950	4.030	2.10 · 10 ⁻³
RPTS Tr 48x8	48	43.468	43.868	37.80	4	100	0.1	3° 18'	0.35	12.00	10.000	5.300	2.90 · 10 ⁻³
RPTS Tr 50x8	50	45.468	45.868	39.30	4	100	0.1	3° 10'	0.34	13.10	11.700	5.960	3.40 · 10 ⁻³
RPTS Tr 55x9	55	50.500	51.060	43.60	4.5	100	0.2	3° 14'	0.33	15.40	17.740	8.140	5.01 · 10 ⁻⁴
RPTS Tr 60x9	60	54.935	55.360	48.15	4.5	200	0.3	2° 57'	0.33	19.00	26.400	11.000	7.30 · 10 ⁻³
RPTS Tr 70x10	70	64.425	64.850	57.00	5	200	0.3	2° 48'	0.32	26.00	51.800	18.200	1.40 · 10 ⁻²
RPTS Tr 80x10	80	74.425	74.850	67.00	5	200	0.3	2° 25'	0.29	34.70	98.900	29.500	2.40 · 10 ⁻²

(1) Thread depth of the basic profile according to DIN 103
(2.1) Self-locking from the movement < 2.4°

(2.2) Self-locking from the fill level > 2.4° < 4.5°
(2.3) No self-locking > 4.5°

(3) Efficiency, calculated with friction value 0.1

Ordering code trapezoidal screw spindle

Ordering code for trapezoidal screw spindle

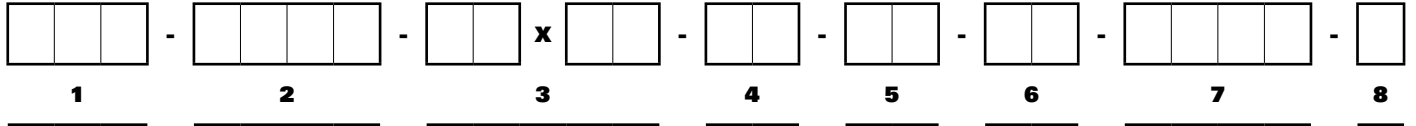

No.	Designation	Code	Description	
1	Product abbreviation	TGS	Trapezoidal Screw Spindle	
2	Spindle abbreviation	RPTS	rolled precision trapezoidal-threaded spindle	
		WPTS	spun precision trapezoidal-threaded spindle	
		RATS	rolled precision A2 trapezoidal-threaded spindle	
		WATS	spun precision A2 trapezoidal-threaded spindle	
3	Thread designation		e.g. 20x4 (diameter 20 mm, pitch 4 mm)	
4	Pitch direction	RH	Right-hand thread	
		LH	Left-hand thread	
5	Spindle end A	O End only sawn and brushed A End with chamfer K End according to customer drawing or project drawing no. D End fixed bearing form D for bearing ZKLF F End fixed bearing form F for bearing ZARN H End fixed bearing form H for bearing ZARF/LTN J End fixed bearing form J for bearing FDX 12-40 L End fixed bearing form L for bearing 7201-7208 S End movable bearing form S for bearing 6001-6211 T End movable bearing form T for needle bearing HK1614-4518 W End movable bearing form W for bearing 6001-6211 Fk End fixed bearing unit FK4-FK30 FF End movable bearing unit FF6-FF30 BK End fixed bearing unit BK10-BK40 BF End movable bearing unit BF10-BF40 M Metric threaded stem SHG AS End hollowing safeguard SHG RS End worm gear connection rotary spindle SHG VS End anti-twist device SHG Z cylindrical bearing journal SHG with rotary spindle		
6	Spindle end B			
7	Overall length in (mm)			e.g. 1000
8	Special requirements		0	none
			1	According to specification, description or drawing

Trapezoidal- threaded nut TGM

Short steel nut blank, cylindrical KSM

Suitable for clamping processes, adjustment movements in manual operation and as a fastening nut. Not suitable for movement drives, since the tribological pairing steel-steel tends towards scuffing.

Further processing: The thread serves as the reference for accurate machining and mounting.

Material: Free-cutting steel 1.0718 (9 SMn 28K)

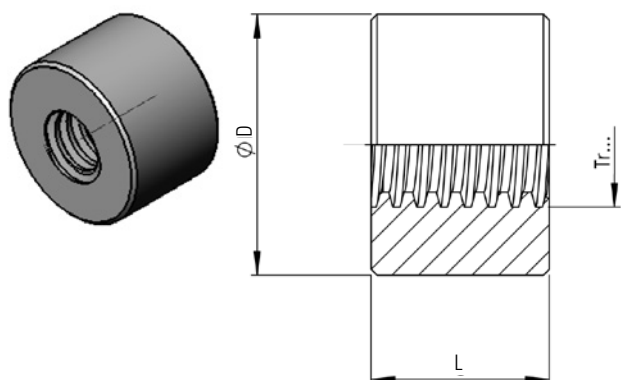

Type	D [mm]	L [mm]	Mass [kg]
KSM Tr 10x2	22	15	0.037
KSM Tr 10x3	22	15	0.036
KSM Tr 12x3	26	18	0.064
KSM Tr 14x3	30	21	0.96
KSM Tr 14x4	30	21	0.96
KSM Tr 16x4	36	24	0.16
KSM Tr 18x4	40	27	0.22
KSM Tr 20x4	45	30	0.31
KSM Tr 22x5	45	33	0.33
KSM Tr 24x5	50	36	0.45
KSM Tr 26x5	50	39	0.47
KSM Tr 28x5	60	42	0.76
KSM Tr 30x6	60	45	0.79
KSM Tr 32x6	60	48	0.81
KSM Tr 36x6	75	54	1.5
KSM Tr 40x7	80	60	1.9
KSM Tr 44x7	80	66	2.7
KSM Tr 48x8	90	72	2.9
KSM Tr 50x8	90	75	2.7
KSM Tr 60x9	100	90	3.7
KSM Tr 70x10	110	105	4.9
KSM Tr 80x10	120	120	6.4

Hexagonal steel nut SKM

Suitable for clamping processes, adjustment movements in manual operation and as a fastening nut. Not suitable for movement drives, since the tribological pairing steel-steel tends towards scuffing.

Further processing: The thread serves as the reference for accurate machining and mounting.

Material: Free-cutting steel 1.0718 (9 SMn 28K)

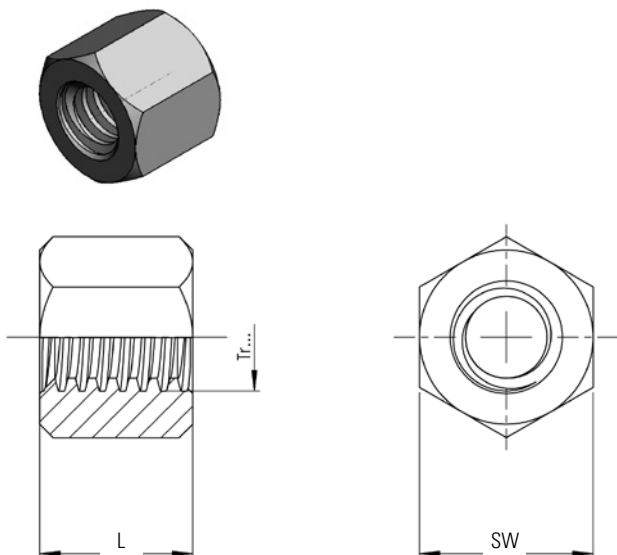

Type	SW [mm]	L [mm]	Mass [kg]
SKM Tr 10x2	17	15	0.022
SKM Tr 10x3	17	15	0.022
SKM Tr 12x3	19	18	0.028
SKM Tr 14x3	22	21	0.044
SKM Tr 14x4	22	21	0.044
SKM Tr 16x4	27	24	0.084
SKM Tr 18x4	27	27	0.086
SKM Tr 20x4	30	30	0.17
SKM Tr 22x5	30	33	0.17
SKM Tr 24x5	36	36	0.20
SKM Tr 26x5	36	39	0.20
SKM Tr 28x5	41	42	0.30
SKM Tr 30x6	46	45	0.43
SKM Tr 32x6	46	48	0.42
SKM Tr 36x6	55	54	0.73
SKM Tr 40x7	65	60	1.3
SKM Tr 44x7	65	66	1.2
SKM Tr 48x8	75	72	1.8
SKM Tr 50x8	75	75	1.8
SKM Tr 60x9	90	90	2.8
SKM Tr 70x10	90	105	3.1

Trapezoidal- threaded nut TGM

Type	D [mm]	L [mm]	Mass [kg]	Bearing percentage [mm ²]
LRM Tr 10x2	22	20	0.056	200
LRM Tr 10x3	22	20	0.056	190
LRM Tr 12x3	26	24	0.092	280
LRM Tr 12x6 P3	26	24	0.092	280
LRM Tr 14x3	30	28	0.14	380
LRM Tr 14x4	30	28	0.14	370
LRM Tr 16x2	36	32	0.25	490
LRM Tr 16x4	36	32	0.25	490
LRM Tr 16x8 P4	36	32	0.25	490
LRM Tr 18x4	40	36	0.34	630
LRM Tr 18x8 P4	40	36	0.34	630
LRM Tr 20x4	45	40	0.48	790
LRM Tr 20x8 P4	45	40	0.45	790
LRM Tr 20x16 P4	45	40	0.45	790
LRM Tr 22x5	45	40	0.46	850
LRM Tr 22x24 P4S	45	40	0.46	880
LRM Tr 24x5	50	48	0.69	1130
LRM Tr 24x10 P5	50	48	0.65	1130
LRM Tr 26x5	50	48	0.58	1240
LRM Tr 28x5	60	60	1.2	1680
LRM Tr 30x6	60	60	1.2	1780
LRM Tr 30x12 P6	60	60	1.2	1780
LRM Tr 32x6	60	60	1.2	1910
LRM Tr 36x6	75	72	2.2	2610
LRM Tr 36x12 P6	75	72	2.2	2610
LRM Tr 40x7	80	80	2.8	3210
LRM Tr 40x14 P7	80	80	2.8	3210
LRM Tr 44x7	80	80	2.6	3560
LRM Tr 48x8	90	100	4.3	4840
LRM Tr 50x8	90	100	4.2	5060
LRM Tr 60x9	100	120	5.7	7320
LRM Tr 70x10	110	140	7.6	10000
LRM Tr 80x10	120	160	9.7	13200

Long red brass nut, cylindrical LRM

For movement drives with particularly favourable wear characteristics. Suitable for use as a lock nut.

Further processing: The thread serves as the reference for accurate machining and mounting.

Material: 2.1090 (G-CuSn 7Zn Pb (Rg7))

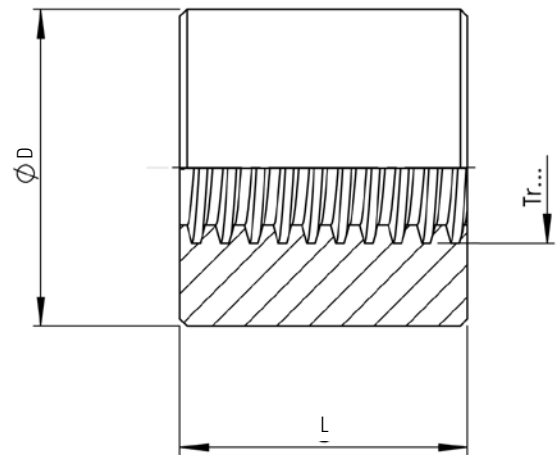
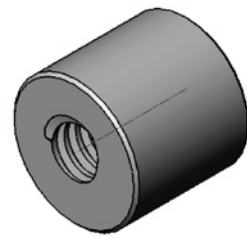

Trapezoidal- threaded nut TGM

Ready-to-install bronze nut EFM

For movement drives with particularly favourable wear characteristics.

Suitable for use as a lock nut.

EFMs can be mounted using the KON and KAR adaptors.

Material: 2.1090 (G-CuSn 7Zn Pb (Rg7))

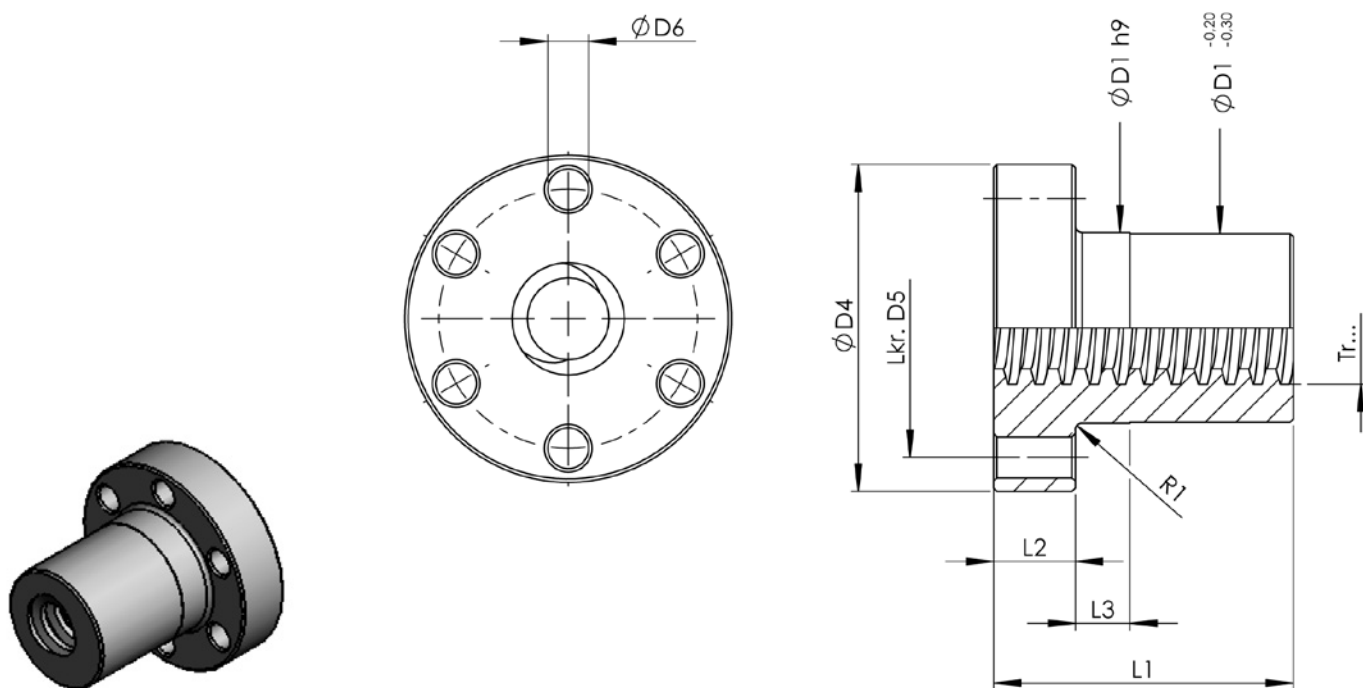

Type	Dimensions [mm]							Mass [kg]	Bearing percentage [mm ²]
	D ₁	D ₄	D ₅	6xD ₆	L ₁	L ₂	L ₃		
EFM Tr 12x3	24	40	32	6	28	12	10	0.11	520
EFM Tr 12x6 P3	24	40	32	6	28	12	10	0.11	520
EFM Tr 16x4	28	48	38	6	44	12	8	0.25	670
EFM Tr 16x8 P4	28	48	38	6	44	12	8	0.25	670
EFM Tr 18x4	28	48	38	6	44	12	8	0.25	770
EFM Tr 18x8 P4	28	48	38	6	44	12	8	0.25	770
EFM Tr 20x4	32	55	45	7	44	12	8	0.30	870
EFM Tr 20x8 P4	32	55	45	7	44	12	8	0.30	870
EFM Tr 20x16 P4	32	55	45	7	44	12	8	0.30	870
EFM Tr 24x5	32	55	45	7	44	12	8	0.30	1040
EFM Tr 24x10 P5	32	55	45	7	44	12	8	0.30	1040
EFM Tr 30x6	38	62	50	7	46	14	8	0.40	1370
EFM Tr 30x12 P5	38	62	50	7	46	14	8	0.40	1370
EFM Tr 36x6	45	70	58	7	59	16	10	0.60	2140
EFM Tr 36x12 P5	45	70	58	7	59	16	10	0.60	2140
EFM Tr 40x7	63	95	78	9	73	16	10	1.70	2930
EFM Tr 40x14 P7	63	95	78	9	73	16	10	1.70	2930
EFM Tr 50x8	72	110	90	11	97	18	10	2.60	4900
EFM Tr 60x9	85	125	105	11	99	20	10	3.70	6040
EFM Tr 70x10	95	180	140	17	100	30	16	7.80	8250
EFM Tr 80x10	105	190	150	17	110	30	16	8.90	10890

Trapezoidal- threaded nut TGM

Safety trap nut SFM

Safety trap nuts are used wherever increased operational reliability is demanded and in order to limit the economic damages in case of a nut breakage.

Safety trap nuts for VBG 14 or VBG 70 requirements on enquiry.

The safety trap nut runs along with the travelling nut without axial load and thus wear-free. As wear of the travelling nut increases, the distance X between the two nuts decreases.

The travelling nut must be replaced when the distance X is reduced by 25%.

If the thread turns of, the travelling nut should break through due to excessive wear, the safety trap nut absorbs the applied load.

The safety trap nut can only be ordered in conjunction with the flange nut.

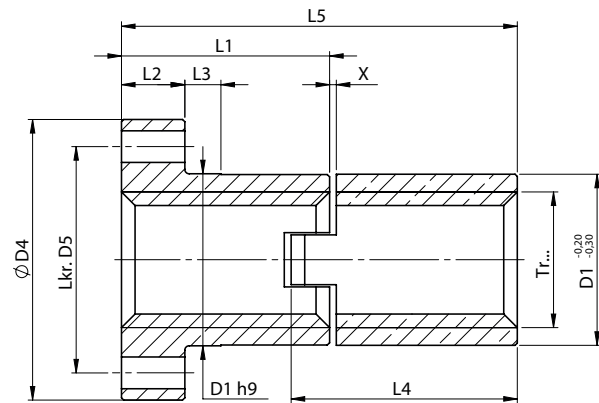
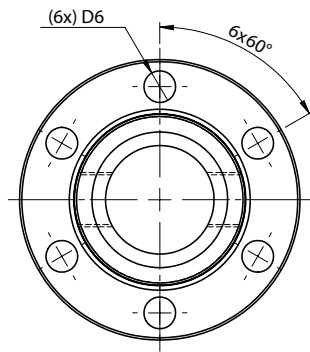
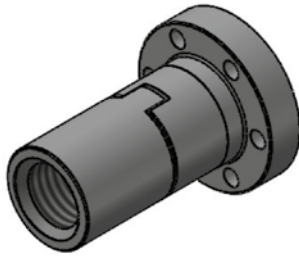

Type	D ₁ [mm]	D ₄ [mm]	D ₅ [mm]	6xD ₆ [mm]	L ₁ [mm]	L ₂ [mm]	L ₃ [mm]	L ₄ [mm]	L ₅ [mm]	X [mm]	mass [kg]	Bearing percentage [mm ²]
EFM-SFM Tr 12x3	24	40	32	6	28	12	10	24	48	4	0.2	520
EFM-SFM Tr 12x6 P3	24	40	32	6	28	12	10	24	48	4	0.2	520
EFM-SFM Tr 16x4	28	48	38	6	44	12	8	32	72	4	0.5	670
EFM-SFM Tr 16x8 P4	28	48	38	6	44	12	8	32	72	4	0.5	670
EFM-SFM Tr 18x4	28	48	38	6	44	12	8	36	76	4	0.59	770
EFM-SFM Tr 20x4	32	55	45	7	44	12	8	40	80	4	0.75	870
EFM-SFM Tr 20x8 P4	32	55	45	7	44	12	8	40	80	4	0.75	870
EFM-SFM Tr 20x16 P4	32	55	45	7	44	12	8	40	80	4	0.75	870
EFM-SFM Tr 24x5	32	55	45	7	44	12	8	48	88	4	0.95	1040
EFM-SFM Tr 24x10 P5	32	55	45	7	44	12	8	48	88	4	0.95	1040
EFM-SFM Tr 30x6	38	62	50	7	46	14	8	60	102	4	1.6	1370
EFM-SFM Tr 30x12 P6	38	62	50	7	46	14	8	60	102	4	1.6	1370
EFM-SFM Tr 36x6	45	70	58	7	59	16	10	72	127	4	2.8	2140
EFM-SFM Tr 36x12 P6	45	70	58	7	59	16	10	72	127	4	2.8	2140
EFM-SFM Tr 40x7	63	95	78	9	73	16	10	80	149	4	4.5	2930
EFM-SFM Tr 40x14 P7	63	95	78	9	73	16	10	80	149	4	4.5	2930
EFM-SFM Tr 50x8	72	110	90	11	97	18	10	100	193	4	6.8	4900
EFM-SFM Tr 60x9	85	125	105	11	99	20	10	120	215	8	9.4	6040
EFM-SFM Tr 70x10	95	180	140	17	100	30	16	140	236	8	15.4	8250
EFM-SFM Tr 80x10	105	190	150	17	110	30	16	160	266	8	18.6	10890

Trapezoidal- threaded nut TGM

Long plastic nut blank, cylindrical LKM

For low-noise movement drives with higher speed and higher duty cycle too. Particularly recommend for use with rolled trapezoidal spindles. Good emergency running characteristics.

Material: PETP

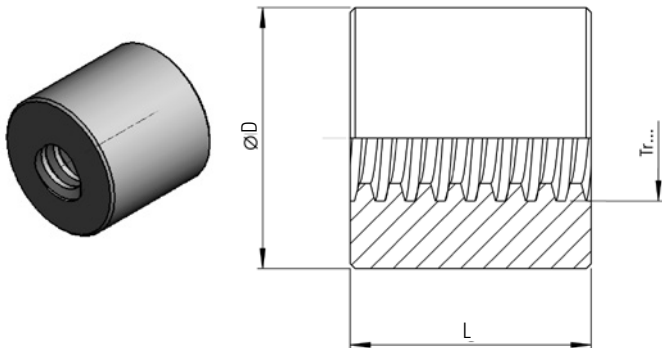

Type	D [mm]	L [mm]	Mass [kg]	Bearing percentage [mm ²]
LKM Tr 12x3	26	24	0.012	280
LKM Tr 12x6 P3	26	24	0.012	280
LKM Tr 16x4	36	32	0.032	490
LKM Tr 16x8 P4	36	32	0.032	490
LKM Tr 20x4	45	40	0.06	790
LKM Tr 20x8 P4	45	40	0.06	790
LKM Tr 24x5	50	48	0.088	1130
LKM Tr 24x10 P5	50	48	0.088	1130
LKM Tr 30x6	60	60	0.15	1780
LKM Tr 30x12 P6	60	60	0.15	1780
LKM Tr 36x6	75	72	0.30	2610
LKM Tr 36x12 P6	75	72	0.30	2610
LKM Tr 40x7	80	80	0.37	3210
LKM Tr 40x14 P7	80	80	0.37	3210
LKM Tr 50x8	90	100	0.55	5060

Ordering code for trapezoidal-threaded nuts

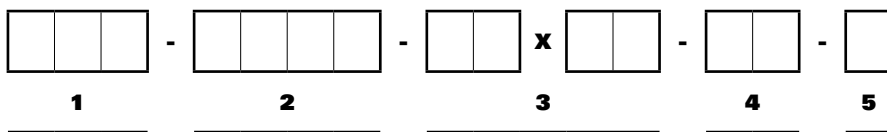

No.	Designation	Code	Description
1	Product abbreviation	TGM	
2	Spindle abbreviation	KSM	Short steel nut blank, cylindrical
		SKM	Hexagonal steel nut
		LRM	Long red brass nut
		EFM	Ready-to-install bronze nut
		LKM	Long plastic nut, cylindrical
		SFMM	Safety trap nut (located on flange side)
3	Thread designation		e.g. 20x4 (diameter 20 mm, pitch 4 mm)
4	Pitch direction	RH	Right-hand thread
		LH	Left-hand thread
5	Special requirements	0	None
		1	According to specification, description or drawing

Ordering code

trapezoidal screw drive

Ordering code for trapezoidal screw drive

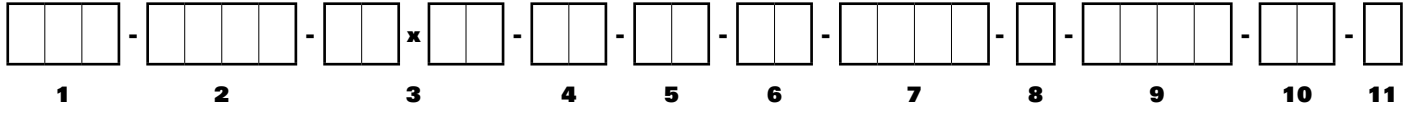

No.	Designation	Code	Description
1	Product abbreviation	TGS	
2	Spindle abbreviation	RPTS	rolled precision trapezoidal-threaded spindle
		WPTS	spun precision trapezoidal-threaded spindle
		RATS	rolled precision A2 trapezoidal-threaded spindle
		WATS	spun precision A2 trapezoidal-threaded spindle
3	Thread designation		e.g. 20x4 (diameter 20 mm, pitch 4 mm)
4	Pitch direction	RH	Right-hand thread
		LH	Left-hand thread
5	Spindle end A	O A K D F H J L S T W Fk FF BK BF M AS RS VS Z	Ends only sawn and brushed
6	Spindle end B		End with chamfer
			End according to customer drawing or project drawing no.
			End fixed bearing form D for bearing ZKLF
			End fixed bearing form F for bearing ZARN
			End fixed bearing form H for bearing ZARF/LTN
			End fixed bearing form J for bearing FDX 12-40
			End fixed bearing form L for bearing 7201-7208
			End movable bearing form S for bearing 6001-6211
			End movable bearing form T for needle bearing HK1614-4518
			End movable bearing form W for bearing 6001-6211
			End fixed bearing unit FK4-FK30
			End movable bearing unit FF6-FF30
			End fixed bearing unit BK10-BK40
		End movable bearing unit BF10-BF40	
7	Overall length in (mm)		e.g. 1000
8	Special requirements spindle	0	none
		1	According to specification, description or drawing
9	Trapezoidal-threaded nut or nut unit with installation note	KSM	Short steel nut blank, cylindrical
		SKM	Hexagonal steel nut
		LRM	Long red brass nut
		EFM	Ready-to-install bronze nut
		LKM	Long plastic nut, cylindrical
		SFMF	Safety trap nut (safety trap nut located on flange side)
		SFMZ	Safety trap nut (safety trap nut located on centring side)
10		0	With cylindrical nut
		F0	Flange to fixed bearing (or longer spindle end)
		OF	Flange to movable bearing (or shorter spindle end)
11	Special requirements nut	0	none
		1	According to specification, description or drawing

Calculation

trapezoidal screw drive

Calculation of trapezoidal screw drive

Calculations / Values Page Note	Page	Note
Required bearing surface A_{erf}	P. 34	Comparison with bearing surface in nut tables
Feeding speed s	P. 34	-
Drive torque M_{ta}	P. 37	-
Friction coefficient μ_m	P. 37	See also value table for friction coefficient
Efficiency η	P. 37	-
Friction angle ρ'	P. 37	-
Pitch angle α	P. 37	See also spindle value table
Drive power P_a	P. 33	-
Critical speed n_{kr}	P. 35/36	-
Permissible operating speed n_{zul}	P. 35	-
Max. permissible axial spindle load F_k	P. 35/36	-
Permissible axial spindle load K_{zul}	P. 35	-
Sagging of the spindle due to dead weight f_{max}	-	-
Required holding torque m_d	P. 37	-

Trapezoidal screw drive values

Values	Page	Note
Material characteristic values	P. 33	Data for the materials used
pv values	P. 34	for determining the max. permissible sliding speed
Friction value	P. 34	for determining the efficiency
Bearing surface mm^2	P. 26-30	for determining the max. axial force/max surface pressure
Thread depth of basic profile	P. 23/24	for determining the bearing surface
Accuracy	P. 23/24	Specification of the pitch deviation over 300 mm
Straightness	P. 23/24	Specification of the straightness over 300 mm
Pitch	P. 23/24	Distance travelled due to one revolution of the spindle/nut
Pitch angle	P. 23/24	for determining the self-locking/efficiency
Efficiency with friction coefficient μ 0.1	P. 23/24	for other friction values see equation for efficiency and friction coefficients
Linear load	-	for determining the max. sagging of the spindle
Bearing surface	P. 34	Bearing surface of the thread
Geometrical moment of inertia	P. 23/24	for determining the max. sagging of the spindle
Resistive torque	P. 23/24	Drive design
Mass moment of inertia	P. 23/24	Drive design

Calculation

trapezoidal screw drive

Material characteristic values

Material	G-CuSn7ZnPb	G-CuSn12ZnPb	9 SMn 28K	PETP
Min. tensile strength	260 N/mm ²	300 N/mm ²	460 N/mm ²	80 N/mm ²
0.2% yield strength RP 0.2	120 N/mm ²	180 N/mm ²	375 N/mm ²	-
Min. elongation at rupture	12%	8%	8%	-
Brinell hardness HB 10/1000	70	95	159	-
Density	8.8 kg/dm ³	8.71 kg/dm ³	8 kg/dm ³	1.38 kg/dm ³
Elastic module	101000 N/mm ²	100000 N/mm ²	200000 N/mm ²	2800-300 N/mm ²
ph value	300 N/mm ² * m/min	400 N/mm ² * m/min	-	100 N/mm ² * m/min
Impact strength	-	-	-	40 kJm ²
Notch impact strength	-	-	-	4 kJm ²
Thermal expansion	1.75 * 10-5 /°C	1.75 * 10-5 /°C	1.19 * 10-5 /°C	8.5 * 10-5 /°C
Water absorption	-	-	-	0.25%
Water saturation	-	-	-	0.60%
Friction against steel	-	-	-	0.05-0.08
Ball indentation hardness H 358/30	-	-	-	150 N/mm ²
Elongation at yield tension 80 N/mm ²	-	-	-	4-5%
max. surface pressure	< 15 N/mm ²	< 15 N/mm ²	< 15 N/mm ²	10 N/mm ²
max. sliding speed	-	-	-	120 m/min

Drive power

$$P_a = \frac{M_d \cdot n}{9550}$$

M_d Required drive torque [Nm]
 n Spindle speed [1/min]
 P_a Required drive power [kW]

Calculation

trapezoidal screw drive

Load ratings of trapezoidal screw drives

As a general principle, the load rating of trapezoidal screw drives is dependent on their material, surface quality, state of wear, surface pressure, lubrication conditions, running speed and temperature, and thus on the duty cycle and the provision for heat dissipation.

The permissible surface pressure is primarily dependent on the running speed of the screw drive.

With motion drives the surface pressure should not exceed 5 N per mm².

The permissible speed can be calculated from the respective bearing surface of the nut and the pv value of the respective nut material.

A_{erf} Required bearing surface [mm²]
 F_{ax} Total axial load [N]
 P_{zul} Maximum permissible surface pressure = 5 N/mm²

pv-factors See table
 v_{Gzul} Maximum linear running speed [m/min]

D Flank diameter [mm]
 n_{zul} Maximum permissible speed of rotation [1/min]

P Thread pitch [mm]
 s_{zul} Permissible feeding speed [m/min]

Required: What travel speed is still permissible at this load?

Thread pitch $P = 6 \text{ mm}$
 Flank-Ø $D = d - \frac{P}{2}$
 $= 36 - \frac{6}{2} \text{ [mm]}$
 $= 33 \text{ mm}$

With pv value for Rg 7 = 300 m/min

pv-factors Material	pv-factors [N/mm ² · m/min]
G-CuSn 7 ZnPb (Rg 7)	300
G-CuSn 12 (G Bz 12)	400
Plastic (PETP)	100
Cast iron GG 22/GG 25	200

Required bearing surface

(VIII)
$$A_{\text{erf}} = \frac{F_{\text{ax}}}{P_{\text{zul}}}$$

Maximum linear running speed

(IX)
$$v_{\text{Gzul}} = \frac{\text{pv-value}}{P_{\text{zul}}}$$

Maximum permissible speed of rotation

(X)
$$n_{\text{zul}} = \frac{v_{\text{Gzul}} \cdot 1000}{D \cdot \pi}$$

Permissible feeding speed

(XI)
$$s_{\text{zul}} = \frac{n_{\text{zul}} \cdot P}{1000}$$

Example load rating calculation

Given: Screw drive,
 Trapezoidal-threaded spindle with bronze nut $P_{\text{zul}} = 5 \text{ N/mm}^2$,
 Total axial load $F_{\text{ax}} = 10000 \text{ N}$

Required bearing surface A_{erf}

from (VIII)
$$A_{\text{erf}} = \frac{F_{\text{ax}}}{P_{\text{zul}}} = \frac{10000 \text{ N}}{5 \text{ N/mm}^2} = 2000 \text{ mm}^2$$

Selection of the bronze nut from the technical data

36 x 6 with bearing surface $A = 2.140 \text{ mm}^2$

Maximum permissible running speed v_{Gzul}

from (IX)
$$v_{\text{Gzul}} = \frac{\text{pv-value}}{P_{\text{zul}}} = \frac{300 \text{ N/mm}^2 \cdot \text{m/min}}{5 \text{ N/mm}^2} = 60 \text{ m/min}$$

Maximum permissible speed of rotation

from (X)
$$n_{\text{zul}} = \frac{v_{\text{Gzul}} \cdot 1000}{D \cdot \pi} = \frac{60 \text{ m/min} \cdot 1000 \text{ mm/m}}{33 \text{ mm} \cdot \pi} = 579 \text{ 1/min}$$

Permissible feeding speed

from (XI)
$$s_{\text{zul}} = \frac{n_{\text{zul}} \cdot P}{1000} = \frac{579 \text{ 1/min} \cdot 6 \text{ mm}}{1000 \text{ mm/m}} = 3,474 \text{ m/min}$$

Result: At a load of 10.000 N, the trapezoidal screw drive can be operated at a speed of 3.474 metres per min.

Calculation

trapezoidal screw drive

Types of bearing

Typical values for the correction factor f_k according to the classic installation cases for standard spindle bearings.

Neff bearing case I

Fixed bearing – loose end, correction factor $f_k=0,25 / f_{kr}=0,43$

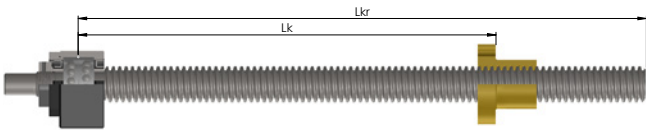

Neff bearing case II

Movable bearing – movable bearing, correction factor $f_k=1 / f_{kr}=1,21$

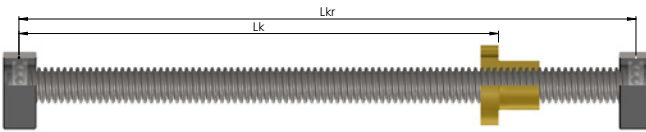

Neff bearing case III

Fixed bearing – movable bearing, correction factor $f_k=2,05 / f_{kr}=1,89$

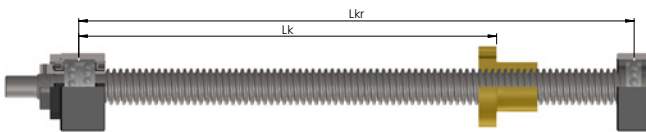

Neff bearing case IV

Fixed bearing – fixed bearing, correction factor $f_k=4 / f_{kr}=2,74$

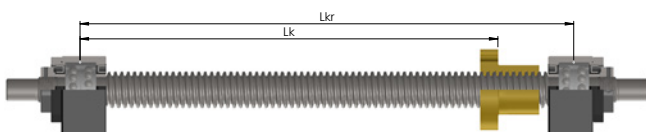

Critical buckling force of ball screws

With slim components such as spindles there is a danger of lateral buckling under axial compressive loads. Using the procedure described below, the permissible, axial force can be determined according to the Euler-Case. The safety factors applying to the system must be considered before determining the permissible compressive force.

Theoretically critical buckling force in [kN]:

$$F_k = \left(\frac{d_2}{L_k} \right)^4 \cdot 10^5 : 1000$$

Maximum permissible axial force in:

$$F_{zul} = F_k \cdot f_k \cdot \frac{1}{S_f}$$

F_{zul}	Maximum permissible axial force [kN]
F_k	Theoretically critical buckling force [kN]
f_k	Correction factor that takes into account the type of spindle bearing
d_2	Core diameter of the spindle [mm]
L_k	Unsupported length on which the force acts on the spindle [mm]
S_f	Safety factor (specified by the user)

Caution!

The operating force must not exceed 80% of the maximum permissible axial force.

Critical speed of ball screws

With slim, rotating components such as spindles there is a risk of resonant vibration. The procedure described below enables the resonant frequency to be estimated, assuming an adequately rigid installation. In addition, speeds close to the critical speed greatly increase the risk of lateral buckling. The critical speed must therefore also be considered in connection with the critical buckling force.

Theoretically critical speed in [1/min]

$$F_{kr} = \left(\frac{d_2}{L_{kr}} \right)^2 \cdot 10^8$$

n_{zul}	Maximum permissible spindle speed [rpm]
n_{kr}	Theoretically critical spindle speed [rpm] that leads to resonant vibrations
f_{kr}	Correction factor that takes into account the type of spindle bearing
d_2	Core diameter of the spindle [mm]
L_{kr}	unsupported spindle length [mm]

Caution!

The operating force must not exceed 80% of the maximum permissible axial force.

Maximum permissible speed of rotation in [rpm]

$$f_{kr} = F_{kr} \cdot f_k \cdot 0,8$$

Calculation

Trapezoidal screw drive

Theoretically permissible buckling force

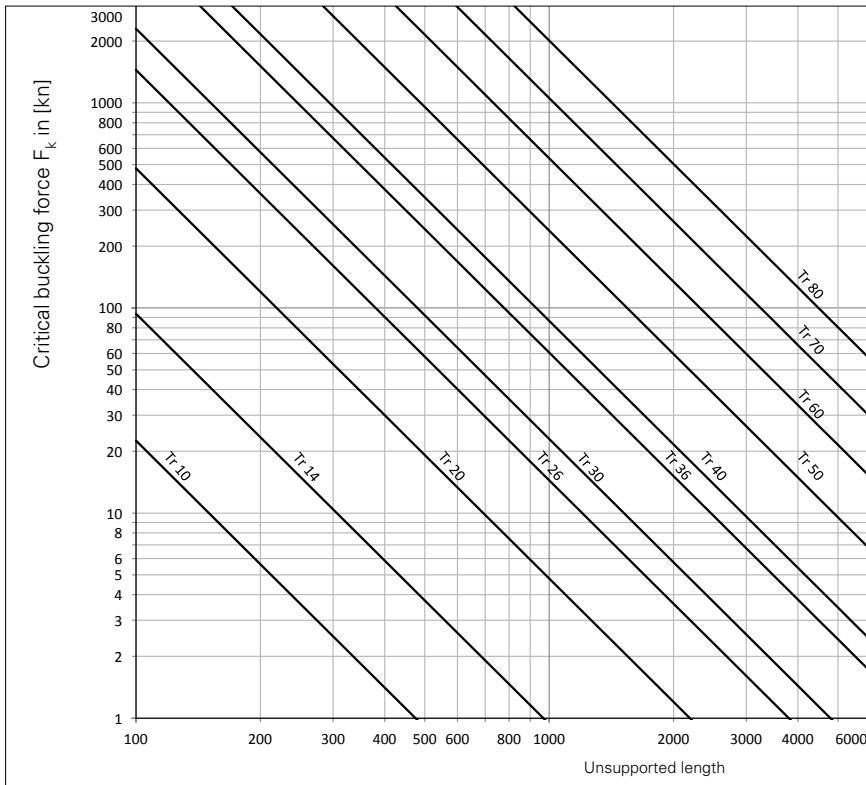

Theoretically permissible speed:

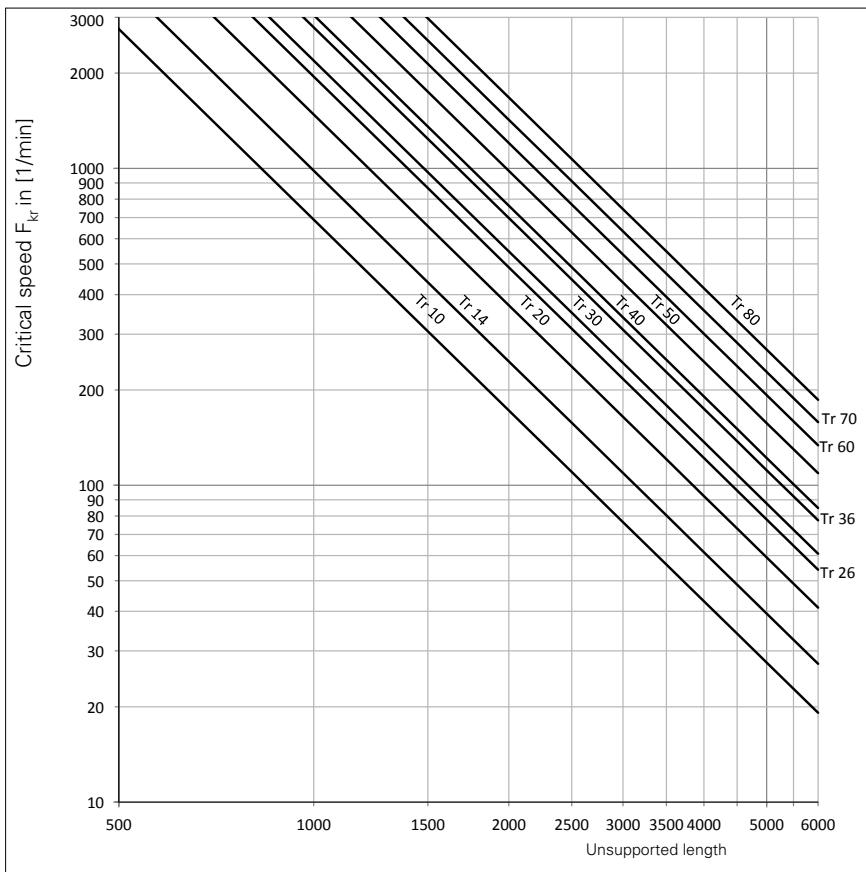

Calculation

Trapezoidal screw drive

Required drive torque and drive power

The required drive moment of a screw drive results from the acting axial load, the thread pitch and the efficiency of the screw drive and its bearing. In case of short acceleration times and high speeds the acceleration torque must be checked.

Fundamentally it must be noted that trapezoidal screw drives have to overcome a breakaway torque when starting up.

Required drive torque

$$M_d = \frac{F_{ax} \cdot P}{2000 \cdot \pi \cdot \eta_A} = + M_{rot}$$

Note:

The required drive torque does not represent a criterion for the selection of the motor. The user must decide here, what power he considers necessary!

Efficiency η for other friction coefficients than $\mu = 0,1$

$$\eta = \frac{\tan \alpha}{\tan (\alpha + \rho')}$$

	μ in start-up ($= \mu_0$)		μ in motion	
	Dry	Lubricated	Dry	Lubricated
Metal nuts	$\approx 0,3$	$\approx 0,1$	$\approx 0,1$	$\approx 0,04$
Plastic nuts	$\approx 0,1$	$\approx 0,04$	$\approx 0,1$	$\approx 0,03$

Required holding torque

$$M_d' = \frac{F_{ax} \cdot P \cdot \eta'}{2000 \cdot \pi} + M_{rot}$$

F_{ax} Total acting axial force [N]
 P Thread pitch [mm]
 η_A Efficiency of the complete drive
 $= \eta_{\text{Ball screw drive}} \cdot \eta_{\text{Fixed bearing}} \cdot \eta_{\text{Movable bearing}}$

$\eta_{\text{TGT}} (\mu = 0.1)$
 $\eta_{\text{Fixed bearing}} = 0.9 \dots 0.95$
 $\eta_{\text{Movable bearing}} = 0.95$
 M_d Required drive torque [Nm]
 M_{rot} Rotary acceleration torque [Nm]
 $= J_{rot} \cdot \alpha_0$
 $= 7,7 \cdot d^4 \cdot L \cdot 10^{-13}$
 J_{rot} Rotary mass moment of inertia [kgm²]
 d Nominal spindle diameter [mm]
 L spindle length [mm]
 α_0 Angular acceleration [rad/s²]

η Efficiency for the transformation of a rotary motion into a longitudinal motion

α Pitch angle of the thread [°]:

$$\tan \alpha = \frac{P}{d_2 \cdot \pi}$$

with P P thread pitch [mm]
 d_2 pitch diameter [mm]

ρ' Thread friction angle [°]
 $\tan \rho' = \mu \cdot 1,07$ for ISO trapezoidal threads
 μ Friction coefficient

Torque due to an axial load

Trapezoidal threads whose pitch angle α is greater than the friction angle ρ' , are not considered to be self-locking. This means that an applied axial load generates a resulting torque on the spindle. The efficiency for the transformation of η' longitudinal motion into a rotary motion is lower than for the transformation of a rotary motion into a longitudinal motion.

F_{ax} Total acting axial force [N]
 P thread pitch [mm]
 η' Efficiency for the transformation of a longitudinal motion into a rotary motion

$$= \frac{\tan (\alpha - \rho')}{\tan \alpha}$$

$$= 0,7 \cdot \eta$$

The influence of the efficiencies of the bearings can be neglected.

M_d' Required holding torque [Nm]
 M_{rot} Rotary acceleration torque [Nm]

$$= J_{rot} \cdot \alpha_0$$

$$= 7,7 \cdot d^4 \cdot L \cdot 10^{-13}$$

J_{rot} Rotary mass moment of inertia [kgm²]
 d Nominal spindle diameter [mm]
 L spindle length [mm]
 α_0 Angular acceleration [rad/s²]

Screw end machining for movable/fixed bearing Form D, F

The type of bearing influences the stiffness of the entire screw drive, and also the vibration and buckling behaviour of the threaded spindle. The end machining is carried out on the ball screw as necessary for the various types of bearing.

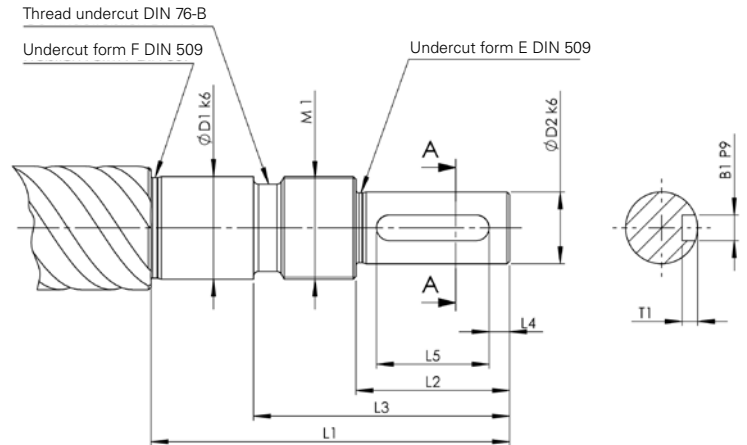

Form D TGS/GGS/KGS	Dimensions [mm]									Bearing ZKLF...2RS
	D ₁	D ₂	L ₁	L ₂	L ₃	L ₄	L ₅	M ₁	B ₁ xT ₁	
Thread core diameter $d_2 > d_1$	12	9	55	20	32	2.5	16	M 12x1	3x1.8	1255
	15	11	58	23	35	3.5	16	M 15x1	4x2.5	1560
	20	14	70	30	44	4	22	M 20x1	5x3	2068
	25	19	82	40	57	6	28	M 25x1.5	6x3.5	2575
	30	24	92	50	67	7	36	M 30x1.5	8x4	3080

Form F TGS/GGS/KGS	Dimensions [mm]									Bearing ZARN...LTN
	D ₁	D ₂	L ₁	L ₂	L ₃	L ₄	L ₅	M ₁	B ₁ xT ₁	
Thread core diameter $d_2 > d_1$	15	11	73	23	35	3.5	16	M 15x1	4x2.5	1545
	20	14	88	30	45	4	22	M 20x1	5x3	2052
	20	14	107	30	50	4	22	M 20x1	5x3	2062
	25	19	105	40	58	6	28	M 25x1.5	6x3.5	2557
	25	19	120	40	63	6	28	M 25x1.5	6x3.5	2572
	35	28	145	60	82	10	40	M 35x1.5	8x4	3585
	40	36	175	80	103	8.5	63	M 40x1.5	10x5	4090

Screw end machining for movable/fixed bearing Form H, J, L

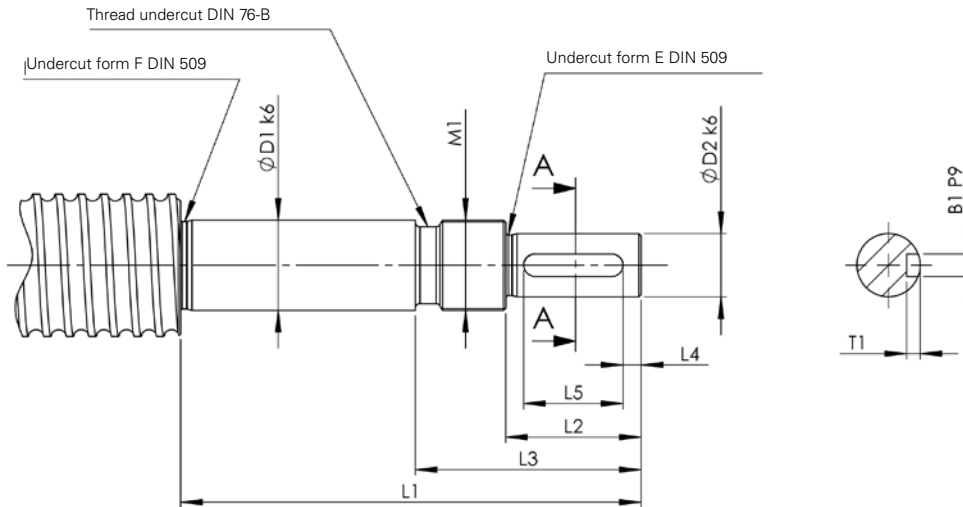

Form H TGS/GGS/KGS	Dimensions [mm]									Bearing ZARF...LTN
	D ₁	D ₂	L ₁	L ₂	L ₃	L ₄	L ₅	M ₁	B ₁ xT ₁	
Thread core diameter $d_2 > d_1$	15	11	85	23	35	3,5	16	M 15x1	4x2,5	1560
	20	14	102	30	44	4	22	M 20x1	5x3	2068
	20	14	122	30	49	4	22	M 20x1	5x3	2080
	25	19	120	40	57	6	28	M 25x1,5	6x3,5	2575
	25	19	135	40	63	6	28	M 25x1,5	6x3,5	2590
	35	28	160	60	81	10	40	M 35x1,5	8x4	35110
	40	36	195	80	105	8,5	63	M 40x1,5	10x5	40115

Form J TGS/GGS/KGS	Dimensions [mm]									Bearing FDX
	D ₁	D ₂	L ₁	L ₂	L ₃	L ₄	L ₅	M ₁	B ₁ xT ₁	
Thread core diameter $d_2 > d_1$	12	9	88	20	32	2,5	16	M 12x1	3x1,8	12
	15	11	92	23	35	3,5	16	M 15x1	4x2,5	15
	20	14	107	30	44	4	22	M 20x1	5x3	20
	25	19	122	40	57	6	28	M 25x1,5	6x3,5	25
	30	24	136	50	72	7	36	M 30x1,5	8x4	30
	40	36	182	80	102	8,5	63	M 40x1,5	10x5	40

Form L TGS/GGS/KGS	Dimensions [mm]									Bearing
	D ₁	D ₂	L ₁	L ₂	L ₃	L ₄	L ₅	M ₁	B ₁ xT ₁	
Thread core diameter $d_2 > d_1$	12	9	58	20	30	2,5	16	M 12x1	3x1,8	7201 BE RS
	15	11	73	23	33	3,5	16	M 15x1	4x2,5	7202 BE RS
	20	14	88	30	43	4	22	M 20x1	5x3	7204 BE RS
	25	19	120	40	55	6	28	M 25x1,5	6x3,5	7205 BE RS
	35	28	145	60	77	10	40	M 35x1,5	8x4	7207 BE RS
	40	36	175	80	103	8,5	63	M 40x1,5	10x5	7208 BE RS

Form A
 Chamfer 2 x 45°: KGS from Ø 12 – 25 mm
 Chamfer 3 x 45°: KGS from Ø 26 – 40 mm
 Chamfer 4 x 45°: KGS from Ø 44 – 50 mm

Screw end machining for movable/fixed bearing Form S, T, W

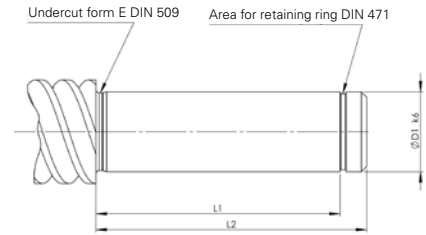

Form S TGS/GGS/KGS	Dimensions [mm]			Spacer bush	Bearing
	D ₁	L ₁	L ₂		
Thread core diameter d ₂ > d ₁	12	40	45	18x12.1x24	6001 RS
	15	46	51	21x15.1x28	6002 RS
	20	53	58	27x20.1x29	6004 RS
	25	53	58	32x25.1x23	6205 RS
	30	60	68	40x30.1x28	6206 RS
	40	80	88	50x40.1x44	6208 RS
	55	102	110	65x55.1x60	6211 RS

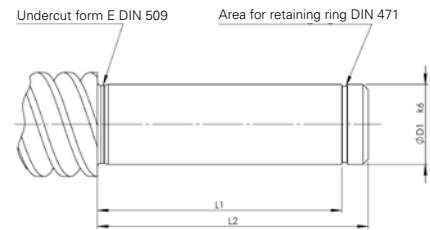

Form T TGS/GGS/KGS	Dimensions [mm]			Inner ring	Needle bearing
	D ₁	L ₁	L ₂		
Thread core diameter d ₂ > d ₁	12	40	45	2 IR 12x16x20	HK 1614 RS
	15	46	51	2 IR 15x20x23	HK 2018 RS
	20	53	58	2 LR 20x25x26.5	HK 2518 RS
	25	53	58	2 LR 25x30x26.5	HK 3018 RS
	30	60	68	2 LR 30x35x30	HK 3518 RS
	40	80	88	4 LR 40x45x20	HK 4518 RS

Form G: Screw end annealed to customer's specification.

Form K: Produced specially to customer's drawing

Form W TGS/GGS/KGS	Dimensions [mm]			Bearing
	D ₁	L ₁	L ₂	
Thread core diameter d ₂ > d ₁	12	8	12	6001 RS
	15	9	13	6002 RS
	20	12	16	6004 RS
	25	15	20	6205 RS
	30	16	21	6206 RS
	40	18	25	6208 RS
55	21	29	6211 RS	

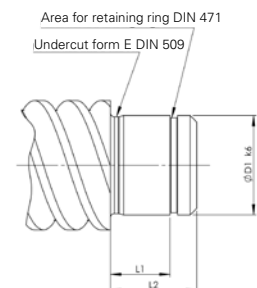

Screw end machining

Form FK - FF - BK - BF

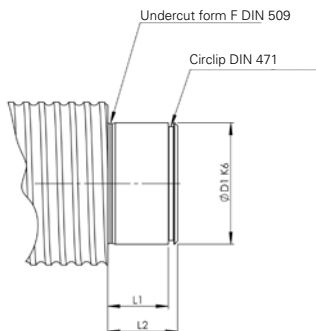
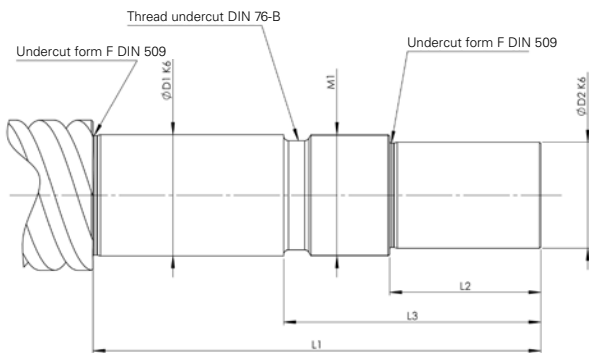
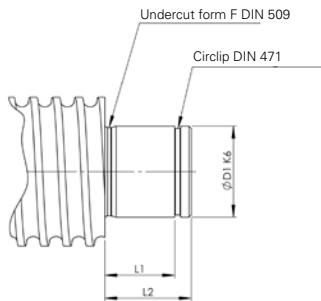
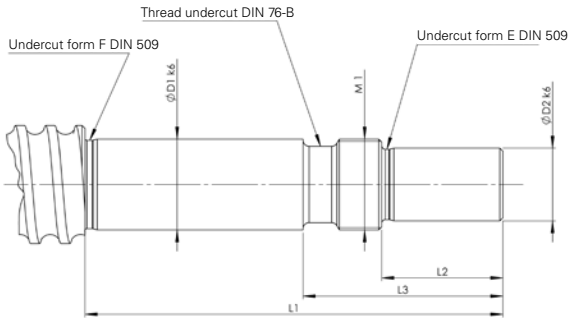

Designation	$\varnothing D_{1 k6}$	$\varnothing D_{2 k6}$	L_1	L_2	L_3	M1
FK 6	6	4	38	8	16	M6x0.75
FK 8	8	6	44	9	19	M8x1
FK 10	10	8	51	15	26	M10x1
FK 12	12	10	51	15	26	M12x1
FK 15	15	12	69	20	33	M15x1
FK 20	20	17	89	25	42	M20x1
FK 25	25	20	106	30	50	M25x1.5
FK 30	30	25	110	38	63	M30x1.5

Designation	$\varnothing D_{1 k6}$	L_2	L_1
FF 10	8	10	7
FF 12	10	11	8
FF 15	15	13	9
FF 20	20	19	14
FF 25	25	20	15
FF 30	30	21	16

Designation	$\varnothing D_{1 k6}$	$\varnothing D_{2 k6}$	L_1	L_2	L_3	M1
BK 10	10	8	54	15	31	M10x1
BK 12	12	10	54	15	29	M12x1
BK 15	15	12	60	20	32	M15x1
BK 17	17	15	76	23	40	M17x1
BK 20	20	17	78	25	40	M20x1
BK 25	25	20	95	30	48	M25x1.5
BK 30	30	25	110	38	63	M30x1.5
BK 35	35	30	128	45	73	M35x1.5
BK 40	40	35	148	50	85	M40x1.5

Designation	$\varnothing D_{1 k6}$	L_2	L_1
BF 10	8	10	7
BF 12	10	11	8
BF 15	15	13	9
BF 17	17	16	12
BF 20	20	16	12
BF 25	25	20	15
BF 30	30	21	16
BF 35	35	22	17
BF 40	40	23	18

Screw end machining Form FL, LLN, LLR

Dimensions

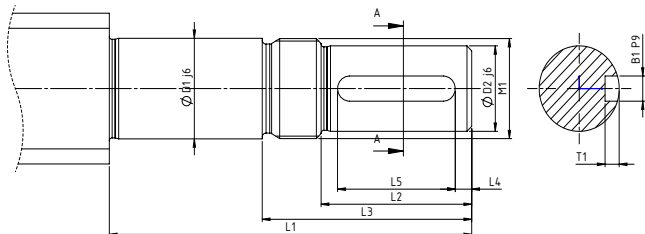

FL01 = Nur für KGS-R-12x05

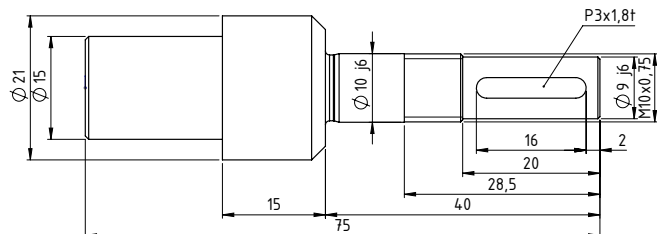

Destination	Dimensions in mm										TGS-Ø	KGS-Ø
	ØD1 j6	ØD2 j6	L1	L2	L3	L4	L5	M1	B1xT1			
FL01	Dimensions according drawing FL01											
FL02	12	10	55	20	28,5	2,5	16	M12x1	3x1,8	18	16	
FL03	15	12	60	25	35	2,5	20	M15x1	4x2,5	24	20	
FL04	20	17	77	32	44,5	3,5	25	M20x1	5x3	30	25	
FL05	25	20	90	40	52	5	30	M25x1,5	6x3,5	36	32	
FL06	25	20	115	50	63,5	7	36	M25x1,5	6x3,5	36	32	
FL07	30	25	128,5	60	74	7,5	45	M30x1,5	8x4	40	40	
FL08	35	28	152,7	80	96	12	56	M35x1,5	8x4	50	50	

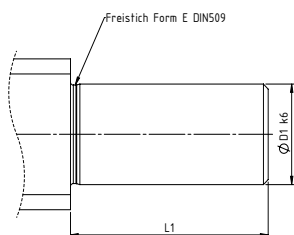

Destination	Dimensions in mm			TGS-Ø	KGS-Ø
	ØD1 j6	L1			
LLN-02	12	32,5	18	16	
LLN-03	15	34	24	20	
LLN-04	20	42	30	25	
LLN-05	25	48	36	32	

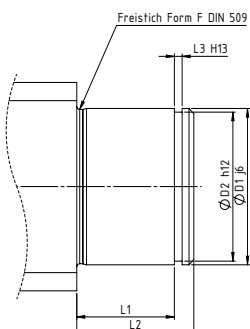

Destination	Dimensions in mm					TGS-Ø	KGS-Ø
	ØD1 j6	ØD2 h12	L1	L2	L3 H13		
LLR-06	25	23,9	18	21,7	1,3	36	32
LLR-07	30	28,6	20	24	1,6	40	40
LLR-08	40	37,5	23	27	1,85	50	50

Bearing units BK-BF

Fixed bearing unit BK

This fixed bearing unit is a pedestal bearing with pre-tensioned axial inclined ball bearings with seals.

The fixed bearing unit is comprised of a burnished steel bearing case with 2 axial inclined ball bearings pre-tensioned by means of a flange, 2 seals with circlips and a securable DRS grooved nut. (Square nuts are used for the smaller sizes).

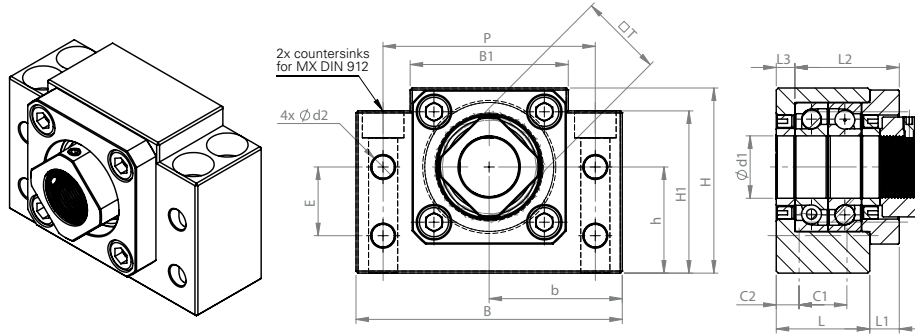

Size	Dimensions in mm																				Bearing designation	C _{stat} in [kN]	C _{dyn} in [kN]	Weight	
	Ø d1	L	L1	L2	L3	B	H	b±0,02	h±0,02	B1	H1	E	P	C1	C2	d2	X	Y	Z	M					T
BK10	10	25	5	29.5	5	60	39	30	22	34	32.5	15	46	13	6	5.5	6.6	10.8	5	M3	16	7000	5.2	1.9	0.4
BK12	12	25	5	29.5	5	60	43	30	25	34	32.5	18	46	13	6	5.5	6.6	10.8	1	M4	19	7001	6	2.1	0.4
BK15	15	27	6	32	6	70	48	35	28	40	38	18	54	15	6	5.5	6.6	11	65	M4	22	7002	6.9	2.4	0.6
BK17	17	35	9	44	7	86	64	43	39	50	55	28	68	19	8	6.6	9	14	85	M4	24	7203	12	4.1	1.3
BK20	20	35	8	43	8	88	60	44	34	52	50	22	70	19	8	6.6	9	14	85	M4	30	7004	13.1	4.2	1.3
BK25	25	42	12	54	9	106	80	53	48	64	70	33	85	22	10	9	11	17	11	M5	35	7205	20.5	7	2.4
BK30	30	45	14	61	9	128	89	64	51	76	78	33	102	23	11	11	14	20	13	M6	40	7206	27.1	9.2	3.4
BK35	35	50	14	67	12	140	96	70	52	88	79	35	114	26	12	11	14	20	13	M8	50	7207	36.8	14.4	4.4
BK40	40	61	18	76	15	160	110	80	60	100	90	37	130	33	14	14	18	26	175	M8	50	7208	46.1	18	6.8

Movable bearing unit BF

This movable bearing unit is a pedestal bearing with a deep-groove ball bearing that adapts itself axially to the elongation of the spindle.

The movable bearing unit consists of a burnished steel bearing case with a deep groove ball bearing.

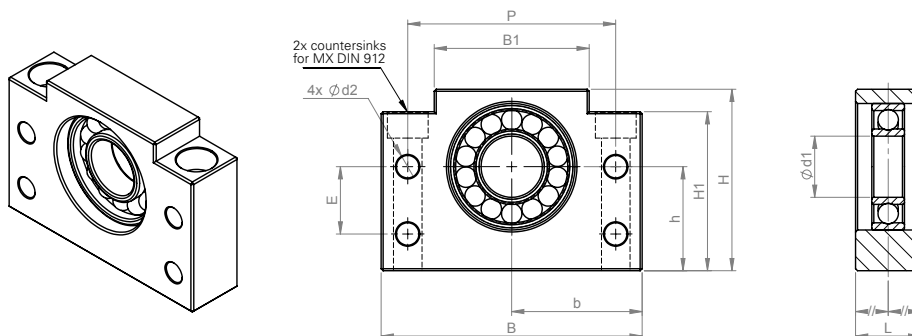

Size	Dimensions in mm															Bearing designation	C _{stat} in [kN]	C _{dyn} in [kN]	Weight
	Ø d1	L	B	H	b±0,02	h±0,02	B1	H1	E	P	d2	X	Y	Z					
BF10	8	20	60	39	30	22	34	32,5	15	46	5,5	6,6	10,8	5	608ZZ	5,2	1,9	0,3	
BF12	10	20	60	43	30	25	34	32,5	18	46	5,5	6,6	10,8	1,5	6000ZZ	6	2,1	0,35	
BF15	15	20	70	48	35	28	40	38	18	54	5,5	6,6	11	6,5	6002ZZ	6,9	2,4	0,4	
BF17	17	23	86	64	43	39	50	55	28	68	6,6	9	14	8,5	6203ZZ	12	4,1	0,75	
BF20	20	26	88	60	44	34	52	50	22	70	6,6	9	14	8,5	6004ZZ	13,1	4,2	0,77	
BF20H	20	26	88	74	44	48	52	64	-	70	-	9	14	8,5	6004ZZ	13,1	4,2	1,017	
BF25	25	30	106	80	53	48	64	70	33	85	9	11	17	11	6205ZZ	20,5	7	1,45	
BF30	30	32	128	89	64	51	76	78	33	102	11	14	20	13	6206ZZ	27,1	9,2	1,95	
BF35	35	32	140	96	70	52	88	79	35	114	11	14	20	13	6207ZZ	36,8	14,4	2,25	
BF40	40	37	160	110	80	60	100	90	37	130	14	18	26	17,5	6208ZZ	46,1	18	3,3	

Bearing units FK-FF

Fixed bearing unit FK

This fixed bearing unit is a flanged bearing with pre-tensioned axial inclined ball bearings with seals.

The fixed bearing unit is comprised of a burnished steel bearing case with 2 axial inclined ball bearings pre-tensioned by means of a flange, 2 seals with circlips and a securable DRS grooved nut. (Square nuts are used for the smaller sizes).

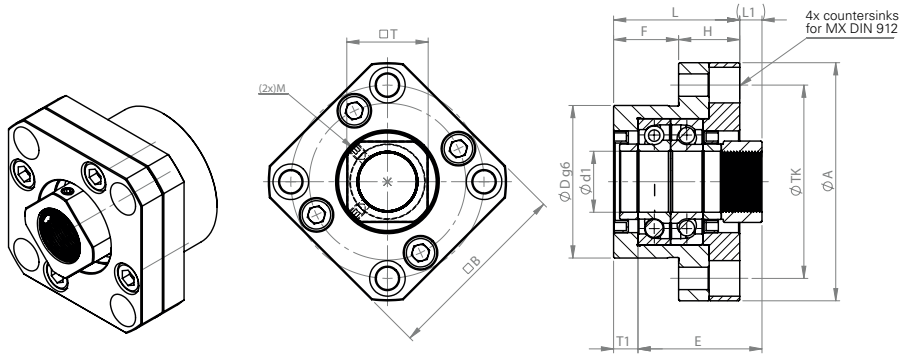

Size	Dimensions in mm																			Bearing designation	C _{stat} in [kN]	C _{dyn} in [kN]	Weight	
	Ø d1	L	H	F	E	D g6	A	TK	B	L1	T1	L2	T2	X	Y	Z	M	T	G					Q
FK05	5	16.5	6	10.5	18.5	20	34	26	26	5.5	3.5	5	3	3.4	6.5	4	M3	11	-	-	605	0.5	0.3	0.1
FK06	6	20	7	13	22	22	36	28	28	5.5	3.5	6.5	4.5	3.4	6.5	4	M3	12	-	-	706A	1	0.7	0.12
FK08	8	23	9	14	26	28	43	35	35	7	4	8	5	3.4	6.5	4	M3	14	-	-	708A	2.7	1	0.16
FK10	10	27	10	17	29.5	34	52	42	42	7.5	5	8.5	6	4.5	8	4	M3	16	-	M6	7000A	5.2	1.9	0.25
FK12	12	27	10	17	29.5	36	54	44	44	7.5	5	8.5	6	4.5	8	4	M4	19	-	M6	7001A	6	2.1	0.26
FK15	15	32	15	17	36	40	63	50	52	10	6	12	8	5.5	9.5	6	M4	22	26	M6	7002A	6.9	2.4	0.4
FK17	17	45	22	23	47	50	77	62	61	11	9	14	12	6.6	11	10	M4	24	30.5	M6	7203A	12	4.1	0.85
FK20	20	52	22	30	50	57	85	70	68	8	10	12	14	6.6	11	10	M4	30	34	M6	7204A	13.1	4.2	1.2
FK25	25	57	27	30	59	63	98	80	79	13	10	20	17	9	15	13	MS	35	39.5	M6	7205A	20.5	7	1.6
FK30	30	62	30	32	61	75	117	95	93	11	12	17	18	11	17.5	15	M6	40	46.5	M6	7206A	27.1	9.2	2.38

Movable bearing units FF

This movable bearing unit is a flanged bearing with a deep-groove ball bearing that adapts itself axially to the elongation of the spindle. The movable bearing unit consists of a burnished steel bearing case with a deep groove ball bearing.

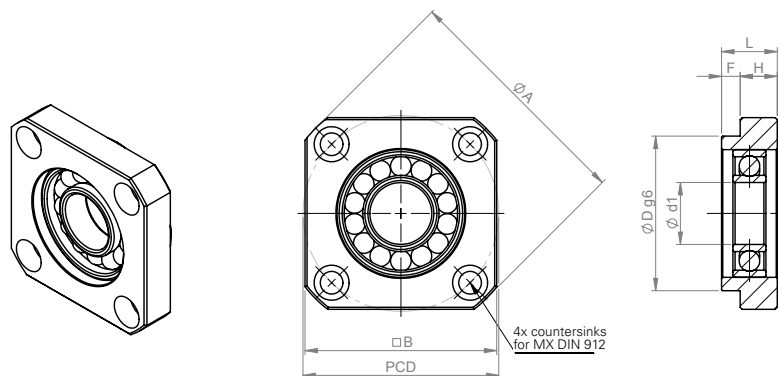

Size	Dimensions in mm											Bearing designation	C _{stat} in [kN]	C _{dyn} in [kN]	Weight
	Ø d1	L	H	F	D g6	A	TK	B	X	Y	Z				
FF 06	6	10	6	4	22	36	28	28	3.4	6.5	4	606ZZ	2	0.7	0.08
FF 10	8	12	7	5	28	43	35	35	3.4	6.5	4	608ZZ	5.2	1.9	0.1
FF 12	10	15	7	8	34	52	42	42	4.5	8	4	6000ZZ	6	2.1	0.15
FF 15	15	17	9	8	40	63	50	52	5.5	9.5	5.5	6002ZZ	6.9	2.4	0.22
FF 17	17	20	11	9	50	77	62	61	6.6	11	6.5	6203ZZ	12	4.1	0.35
FF 20	20	20	11	9	57	85	70	68	6.6	11	6.5	6204ZZ	13.1	4.2	0.45
FF 25	25	24	14	10	63	98	80	79	9	14	8.5	6205ZZ	20.5	7	0.66
FF 30	30	27	18	9	75	117	95	93	11	17	11	6206ZZ	27.1	9.2	1.05

Bearing units FL

Technical data/Dimensions

Fixed bearing unit FL

FL fixed bearing unit with pre-tensioned axial inclined ball bearings up to size FL05. From size FL06 with integrated axial and radial needle bearings. Screw nut conforming to DIN 981 is included in the scope of delivery. Screw end machining: See chapter end machining FL

Housing material: AlCuPbMg (anodised); other housing materials available on request

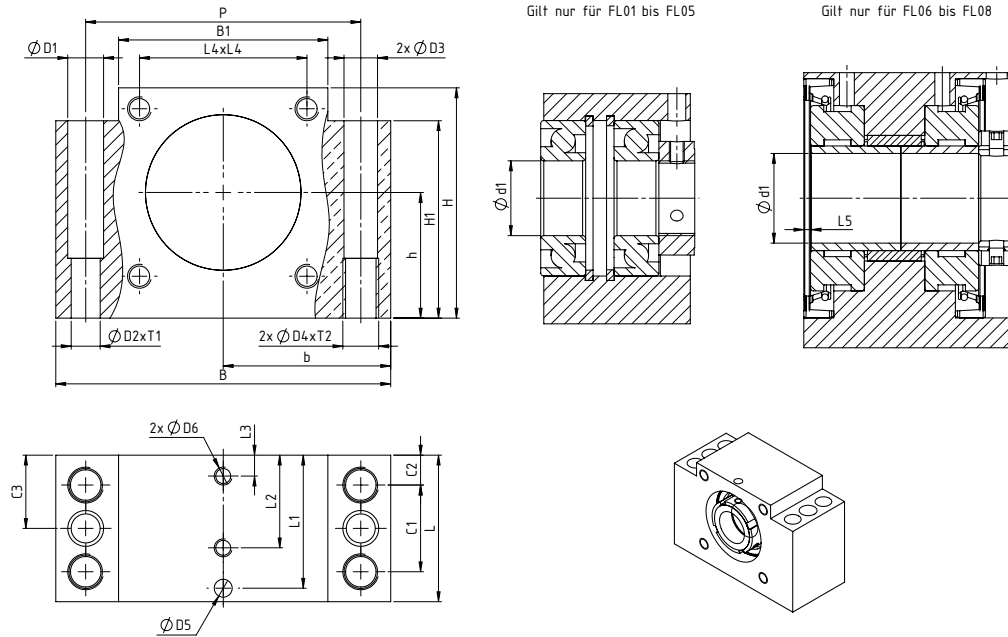

Size	Dimensions in mm																						
	Ød	L	B	H	h js7	H1	B1	P	L1	L2	L3	L4xL4	L5	C1	C2	C3	ØD1	ØD2xT1	2xØD3	2xØD4xT2	ØD5	2xØD6	4xØD7
FL-01	10	32 ¹⁾	62	41	22	34	38	50	-	-	-	28x28	-	16	8	16	5	3,7x10	5,6	M6x10	-	-	M5x10
FL-02	12	37	86	58	32	49	52	68	33	-	-	39x39	-	23	7	18,5	10	7,7x15	9,3	M10x15	6	-	M5x10
FL-03	15	42	94	64	34	55	60	77	37	-	-	45x45	-	25	8,5	21	10	7,7x15	9,3	M10x15	6	-	M6x16
FL-04	20	46	108	72	39	61	68	88	39	-	-	52x52	-	29	8,5	23	12	9,7x22	11,2	M12x20	6	-	M8x16
FL-05	25	49 ²⁾	112	77	42	66	70	92	44,5	-	-	56x56	-	29	10	24,5	12	9,7x20	11,2	M12x20	6	-	M8x16
FL-06	25	71	126	92	50	79	84	105	64,5	48	16,5	-	5,8	44	13,5	35,5	9,7	-	12,6	M14x21	7	M6	-
FL-07	30	71	126	92	50	79	84	105	64,5	46	14,5	-	2,3	44	13,5	35,5	9,7	-	12,6	M14x21	7	M6	-
FL-08	35	75	146	112	60	97	104	125	66,5	47	15,5	-	2,3	50	12,5	37,5	9,7	-	12,6	M14x21	7	M6	-

1) Screw adapter protrudes 20 mm

2) Inclined ball bearing protrudes 1 mm, screw nut protrudes 1.5 mm

Size	TGS/ KGS Ø	Bear- ings	Cstat in [kN]	Cdyn in [kN]	tightening torque [Nm]
FL-01	12	3000-B	3,25	5,7	2
FL-02	16/18	6001	2,37	5,4	6
FL-03	20/24	7202	4,45	8,4	8
FL-04	25/30	7204	7,8	17,0	15
FL-05	32	7205	9,0	15,3	18
FL-06	36	81105	76,0	33,5	25
FL-07	40	81207	199,0	80,0	32
FL-08	50/60/63	81208	265,0	107,0	40

Bearing units LL

Technical data/Dimensions

Movable bearing units LL-K / LL-N / LL-R

LL movable bearing units with LL-K slide bearings (no end machining required), integrated LL-N needle bearings or LL-R deep-groove ball bearings to match the FL fixed bearing units. The LL-R movable bearing units are supplied with a retainer ring conforming to DIN 471.

Screw end machining: See chapter end machining LL

Housing material: AlCuPbMg (anodised), other housing materials available on request

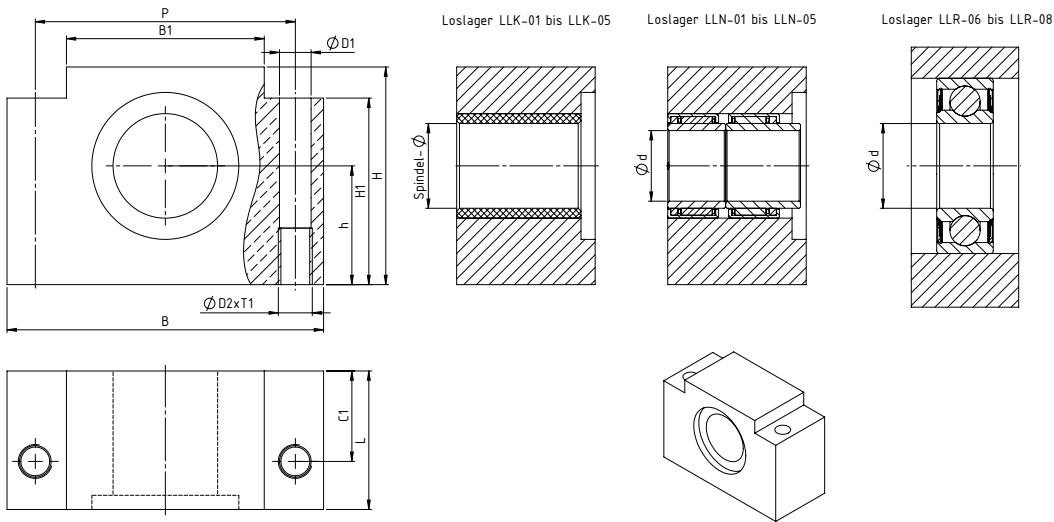

Size	Dimensions in mm										
	Ød	L	B	H	h js7	B1	H1	P	C1	ØD1	ØD2xT1
LLK-01	12	32	62	41	22	38	34	50	24,5	5,6	M6x10
LLK-02	-	37	86	58	32	52	49	68	25	9,3	M10x15
LLN-02	12	37	86	58	32	52	49	68	25	9,3	M10x15
LLK-03	-	42	94	64	34	60	55	77	29	9,3	M10x15
LLN-03	15	42	94	64	34	60	55	77	29	9,3	M10x15
LLK-04	-	46	108	72	39	68	61	88	32	11,2	M12x20
LLN-04	20	46	108	72	39	68	61	88	32	11,2	M12x20
LLK-05	-	49	112	77	42	70	66	92	32	11,2	M12x20
LLN-05	25	49	112	77	42	70	66	92	32	11,2	M12x20
LLR-06	25	38	126	92	50	84	79	105	19	12,6	M14x20
LLR-07	30	38	126	92	50	84	79	105	19	12,6	M14x20
LLR-08	40	44	146	112	60	104	97	125	22	12,6	M14x20

Size	TGS	KGS	Bearing	Cstat in [kN]	Cdyn in [kN]
LLK-01	-	12x05	-	-	-
LLK-02	18x4	16x05/20	-	-	-
LLN-02	18x4	16x05/20	HK-1514	9,8	7,8
LLK-03	20x4 / 24x5	20x05/20/50	-	-	-
LLN-03	20x4 / 24x5	20x05/20/50	HK-1814	10,9	8,1
LLK-04	30x6	25x05/10/25	-	-	-
LLN-04	30x6	25x05/10/25	HK2518	24,0	15,6
LLK-05	-	32x05/10	-	-	-
LLN-05	36x6	32x05/10	HK-3018	29,0	17,2
LLR-06	36x6	32x10/20/40	62205	7,8	14,9
LLR-07	40x7 / 40x14P7	40x05/10/20	62206	11,3	20,7
LLR-08	50x8 / 60x9	50x10/20 / 63x10	62208	17,8	31,0

Bearing units SEB-FN

Technical data/Dimensions

Pillow block unit SEB-FN

Fixed bearing unit as pedestal bearing with pre-tensioned axial inclined ball bearings as a heavy-duty series. The fixed bearing unit consists of a burnished steel bearing housing, ZKLN axial inclined ball bearings, a bearing cover and a precision screw nut (see table for torques).

Size SEB-FN-1605-10-16-40 and SEB-FN-2005-20-50 with grooved screw nut

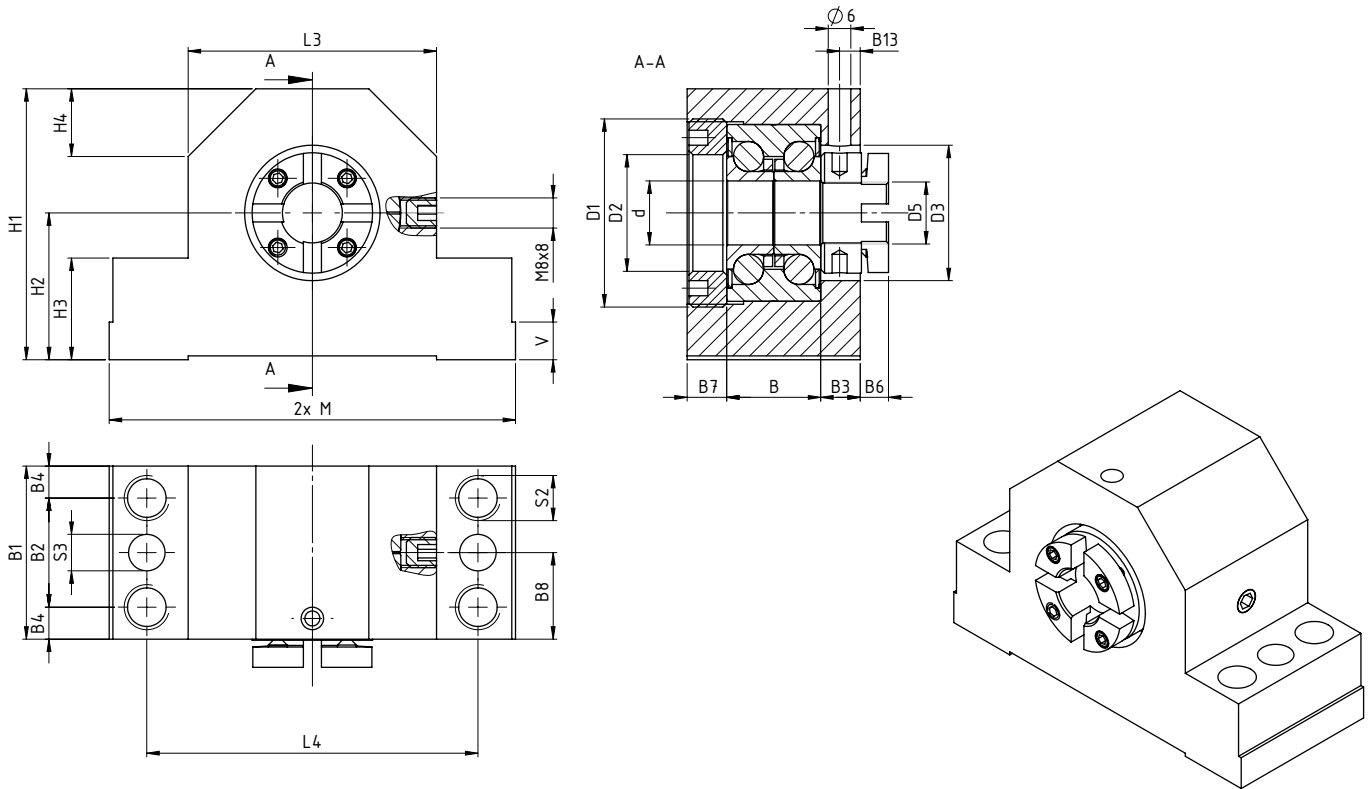

Size	C dyn. [N]	C stat. [N]	M js6	L3	L4	H1	H2 ±0,02	H3	H4	B	B1	B2	B3	B4	B6	B7	B8	B13
SEB-FN-1605-10-16-40	13250	18500	43	52	68	58	32	22	14	20	37	23	8,5	7	-	8,5	18,5	4,5
SEB-FN-2005-20-50	17000	24500	47	60	77	64	34	22	16	25	42	25	8,5	8,5	-	8,5	21	3,5
SEB-FN-2505-10-25-50	18500	31000	54	66	88	72	39	27	18	25	46	29	10,5	8,5	7,5	10,5	23	5,5
SEB-FN-3205-10-20-40-60	26000	47000	56	70	92	77	42	27	19	28	49	29	10,5	10	7,5	10,5	24,5	4,5
SEB-FN-4005-10-20-40	44500	111000	63	80	105	98	58	32	23	56	89	62	20,5	13,5	-	12,5	54,5	14,5
SEB-FN-5010-20-50	47500	127000	72	92	118	112	65	38	25	56	92	65	20,5	13,5	-	15,5	57,5	14,5
SEB-FN-6310-20-40	72000	149000	95	130	160	138	73	50	35	46	85	58	22,5	13,5	-	16,5	39,5	16,5
SEB-FN-8010-20-40	113000	250000	102,5	145	175	165	93	50	40	54	98	58	25,5	20	-	18,5	45,5	17,5

Size	V	S2	S3	d H7	D1	D2	D3	D5	tightening torque spindle nut [Nm]
SEB-FN-1605-10-16-40	8	8,5	7,7	10	M36x1,5	22	27	M10x1	6
SEB-FN-2005-20-50	8	8,5	7,7	12	M45x1,5	28	32	M12x1	8
SEB-FN-2505-10-25-50	10	10,25	9,7	17	M50x1,5	31	36	M17x1	15
SEB-FN-3205-10-20-40-60	10	10,25	9,7	20	M55x1,5	36	42	M20x1	18
SEB-FN-4005-10-20-40	12	12	9,7	25	M62x1,5	43	48	M25x1,5	25
SEB-FN-5010-20-50	12	12	9,7	30	M78x2	54	53	M30x1,5	32
SEB-FN-6310-20-40	16	12	9,7	40	M95x2	68	72	M40x1,5	55
SEB-FN-8010-20-40	16	17,5	11,7	50	M115x2	85	90	M50x1,5	85

Bearing units SEB-LN

Technical data/Dimensions

Pillow block unit SEB-LN

Movable bearing unit as pedestal bearing with deep-groove ball bearings to match the SEB-FN pillow block units. The movable bearing unit consists of a burnished steel bearing housing, deep-groove ball bearings conforming to DIN 625, a retainer ring conforming to DIN 471 and a bearing cover. Accessories are supplied loose.

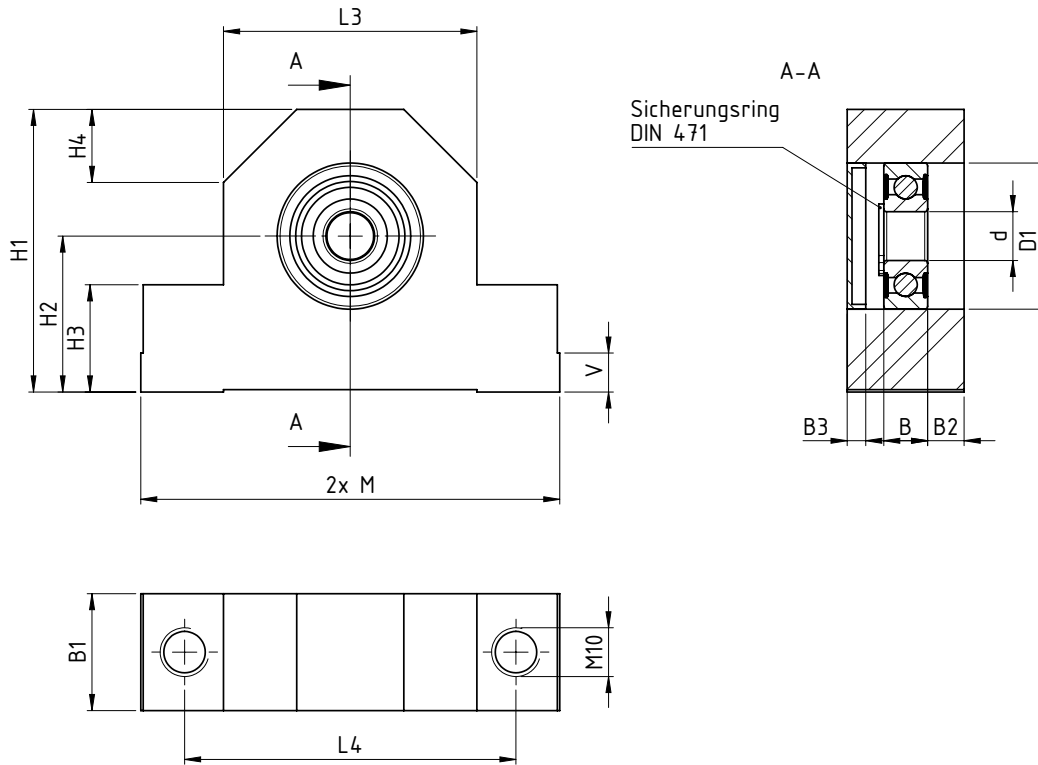

Size	C dyn. [N] (Radial)	C stat. [N] (Radial)	M js7	L3	L4	H1	H2 ±0,02	H3	H4	B	B1	B2	B3	V	S2	d	D1 j6	Circlip DIN 471	Weight [kg]
SEB-LN-1605-10-16-40	6000	2240	43	52	68	58	32	22	15	9	24	7,5	3,8	8	M10	10	30	10x1	0,54
SEB-LN-2005-20-50	6950	2650	47	60	77	64	34	22	17	10	26	8	3,8	8	M10	12	32	12x1	0,73
SEB-LN-2505-10-25-50	9500	4150	54	66	88	72	39	27	19	12	28	10	3,7	10	M12	17	40	17x1	0,96
SEB-LN-3205-10-20-40-60	12700	5700	56	70	92	77	42	27	20	14	34	10	4,8	10	M12	20	47	20x1,2	1,24
SEB-LN-4005-10-20-40	19300	9800	63	80	105	98	58	32	23	16	38	12	4,5	12	M14	30	62	30x1,5	1,82
SEB-LN-5010-20-50	25500	13200	72	92	118	112	65	38	25	17	41	12	5	12	M14	35	72	35x1,5	2,87
SEB-LN-6310-20-40	36500	20800	95	130	160	138	73	50	35	20	46	16	5	16	M14	50	90	50x2	5,39
SEB-LN-8010-20-40	52000	31000	102,5	145	175	165	93	50	40	22	50	16	6	16	M20	60	110	60x2	7,09

Grooved nuts

DRS

This is a securable grooved nut that is secured by two radial brass pins.

Material: heat treated steel, min. 800 N/mm²

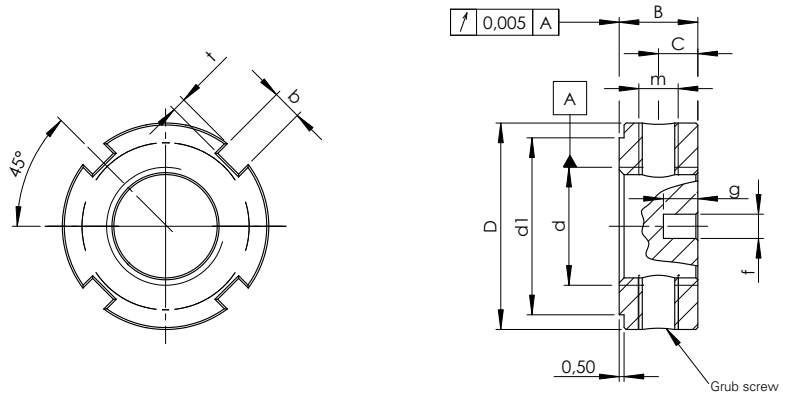

Size	d	D	B	d ₁	c	m	b	t	e	f	g	(Nm)
DRS 6x0.5	M 6x0.5	16	8	12	4	M4	3	2	11	2.5	3.5	2
DRS 10x1	M 10x1	18	8	14	4	M4	3	2	14	2.5	3.5	6
DRS 12x1	M 12x1	22	8	18	4	M4	3	2	17	2.5	3.5	8
DRS 17x1	M 17x1	28	10	23	5	M5	4	2	22.5	3	4	15
DRS 20x1	M 20x1	32	10	27	5	M5	4	2	26	3	4	18
DRS 30x1.5	M 30x1.5	45	12	40	6	M6	5	2	37.5	4	5	32
DRS 45x1.5	M 45x1.5	65	14	59	7	M6	6	2.5				65
DRS 55x2	M 55x2	75	16	68	8	M6	7	3				95
DRS 60x2	M 60x2	80	16	73	8	M6	7	3				100
DRS 70x2	M 70x2	92	18	85	9	M8	8	3.5				130
DRS 80x2	M 80x2	105	18	95	9	M8	8	3.5				160
DRS 90x2	M 90x2	120	20	108	10	M8	10	4				200

GUK

Self-locking grooved nut with polyamide ring.
Secured by a polyamide ring - usable up to max. 100 °C.

Material (strength class): min. 14 H, galvanised and passivated

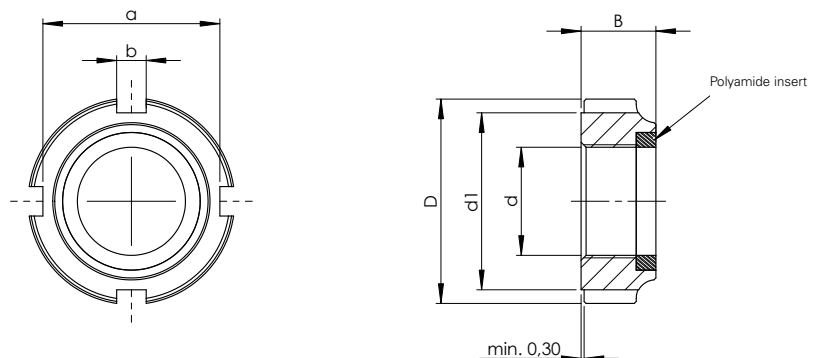

Size	d	D	B	d ₁	a	b	(Nm)	Weight
GUK 12x1	M 12x1	21	7.6	18	18	3	8	10
GUK 15x1	M 15x1	24	8.6	21	21	4	10	13
GUK 20x1	M 20x1	32	9.6	27	27	4	18	24

Adaptor bracket KON

Adaptor bracket for radial fastening of trapezoidal-threaded flanged nuts EFM or ball screw flanged nuts KGF-N/KGF-D according to DIN 69051.

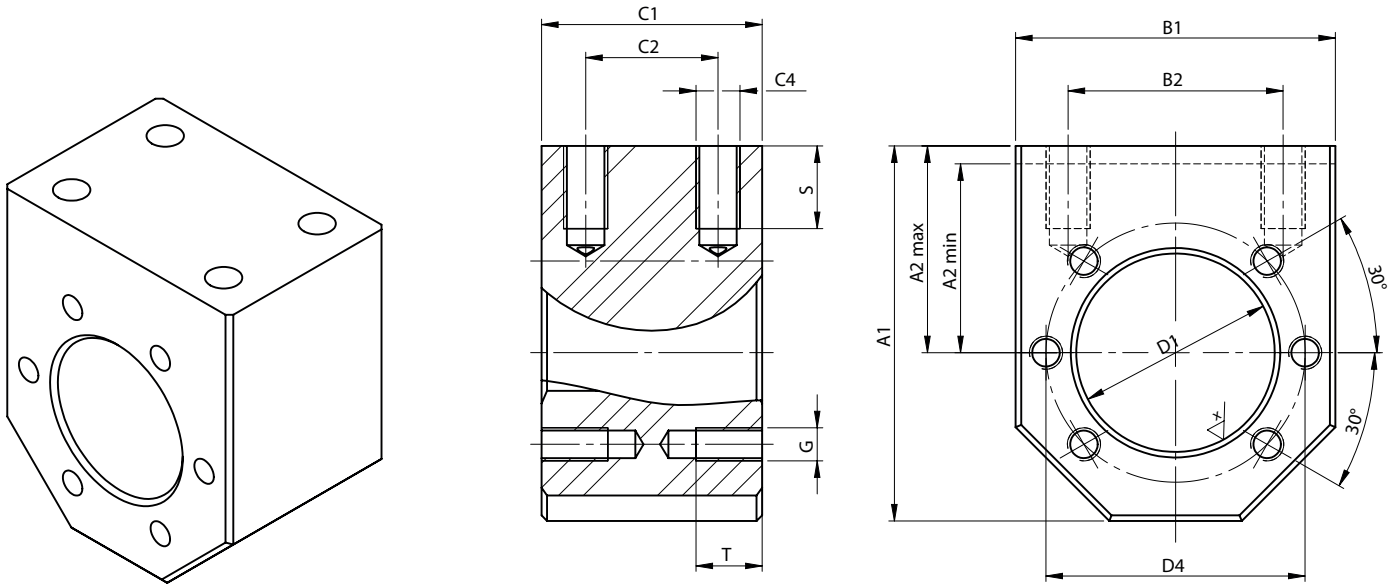

Size	Hole pattern ¹⁾	A1	A2 max	A2 min	B1	B2	C1	C2	C4	S	D1	D4	G	T
KON Tr 16x4/Tr 18x4/KGF-N 1605	3	60	35	25	50	34	40	24	M8	15	28	38	M5	10
KON KGF-D 1605/1610	1	60	35	25	50	34	40	24	M8	15	28	38	M6	10
KON Tr 20x4/Tr 24x5/KGF-N 2005	3	68	37.5	29	58	39	40	24	M8	15	32	45	M6	12
KON KGF-D 2005	1	68	37.5	30	58	39	40	24	M8	15	36	47	M7	12
KON KGF-D 2020/2050	3	75	42.5	32.5	65	49	40	24	M10	15	35	50	M6	12
KON Tr 30x6/KGF-N 2505	3	75	42.5	32.5	65	49	40	24	M10	15	38	50	M6	12
KON KGF-D 2505/2510/2520/2525/2550	1	75	42.5	32.5	65	49	40	24	M10	12	40	51	M6	12
KON Tr 36x6/KGF-N 3205	3	82	45	37	75	54	50	30	M10	12	45	58	M6	12
KON KGF-D 3205	1	92	50	40	85	60	50	30	M12	15	50	65	M8	12
KON KGF-N 3210/3240/4005	3	92	50	42	85	60	50	30	M12	15	53	68	M6	12
KON KGF-D 3210/3220	1	92	50	40	85	60	50	30	M12	15	53	65	M8	12
KON Tr 40x7/KGF-N 4010	3	120	70	50	100	76	65	41	M14	25	63	78	M8	14
KON KGF-D 4005/4010/4020/4040	2	120	70	50	100	76	65	41	M14	25	63	78	M8	14
KON Tr 50x8/KGF-N 5010	3	135	77.5	57.5	115	91	88	64	M16	25	72	90	M10	16
KON KGF-D 5010	2	135	77.5	57.5	115	91	88	64	M16	25	75	93	M10	16
KON KGF-D 5020	2	152	87.5	65	130	101	88	64	M16	30	85	103	M10	16
KON Tr 60x9/KGF-N 6310	3	152	87.5	65	130	101	88	64	M16	30	85	105	M10	16

¹⁾ See catalogue illustration of nut hole pattern

Adapter bracket MAFN

Dimensions

Adapter bracket MAFN

Adapter bracket for radial fastening of TGM-EFM trapezoidal threaded nuts, KGF-D flanged ball nuts conforming to DIN 69051 or flanged ball nuts conforming to the NEFF standard. The MAFN adapter bracket should be fixed to the screwed-on system through the outer edges to establish a form-fitting connection in order to avoid displacement of the mounted position during operation.

Material: AlCuPbMg (anodised); other materials available on request

Standardbohrbild passend zu TGM-EFM/KGF-N

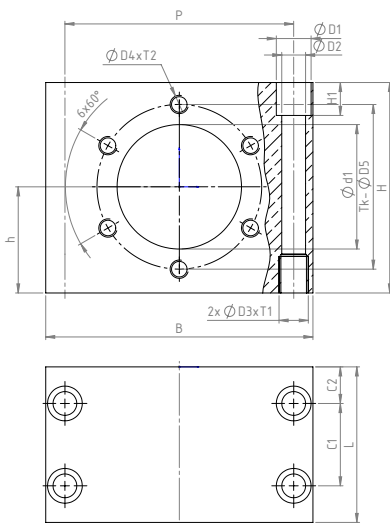

Bohrbild 1 passend zu KGF-D

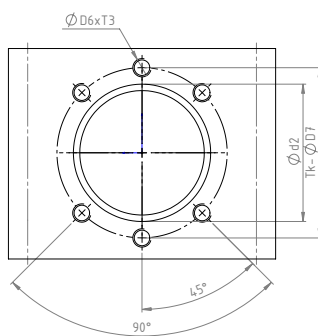

Bohrbild 2 passend zu KGF-D

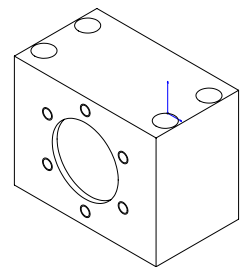
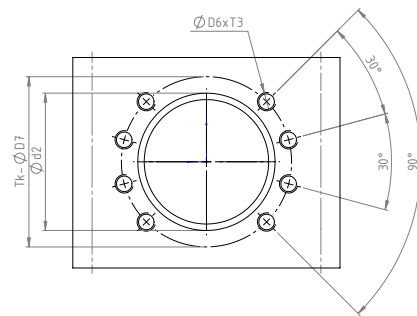

Size	Standard hole pattern - TGM-EFM/KGF-N - Dimensions in [mm]																hole pattern 1 & 2 - KGF-D - Dimensions in [mm]					
	Ød1	L	B	H	h js7	H1	P	C1	C2	ØD1	ØD2	ØD3xT1	ØD4xT2	Tk-ØD5	TGM-EFM	KGM-NF	Bohrbild	Ød2	ØD6xT3	Tk-ØD7	KGM-DF	
MAFN-01	20	35	55	38	21	7	40	20	7,5	10	7,4	M8x12	M4x12	32	-	-	-	-	-	-	-	-
MAFN-02	28	40	70	55	28	11	52	20	10	15	9,3	M10x15	M5x15	38	16xP - 18xP	16x05	1	28	M5x15	38	16x05/16x10	
MAFN-03	32	40	75	62	32	11	56	20	10	15	9,3	M10x15	M6x16	45	20xP - 24xP	20x05	-	-	-	-	-	
MAFN-04	38	40	85	65	34	11	63	20	10	15	9,3	M10x15	M6x16	50	30xP	25x05	-	-	-	-	-	
MAFN-04	-	40	85	65	34	11	63	20	10	15	9,3	M10x15	-	-	-	-	1	40	M6x16	51	25xP	
MAFN-05	45	50	95	74,5	38	13,5	72	26	12	18	11	M12x15	M6x16	58	36xP	32x05	-	-	-	-	-	
MAFN-06	53	60	105	82	42	18	82	30	15	19	13	M16x20	M6x12	68	-	32x10/40 & 40x05	2	63	M8x12	78	40xP	
MAFN-07	53	72	120	94	47	18	99	35	18,5	19	13	M16x20	M6x12	68	40xP	-	2	63	M8x16	78	40xP	
MAFN-08	72	85	146	115	58	18	125	45	20	19	13	M16x20	M10x24	90	50x8	50x10	2	75	M10x24	93	50x10	
MAFN-08	85	85	146	115	58	18	125	45	20	19	13	M16x20	M10x24	105	60x9	63x10	2	90	M10x24	108	63x10	

Universal joint adapter KAR

Universal joint adaptor for universal mounting of trapezoidal-threaded flanged nuts EFM or ball screw flanged nuts KGF-N/KGF-D according to DIN 69051

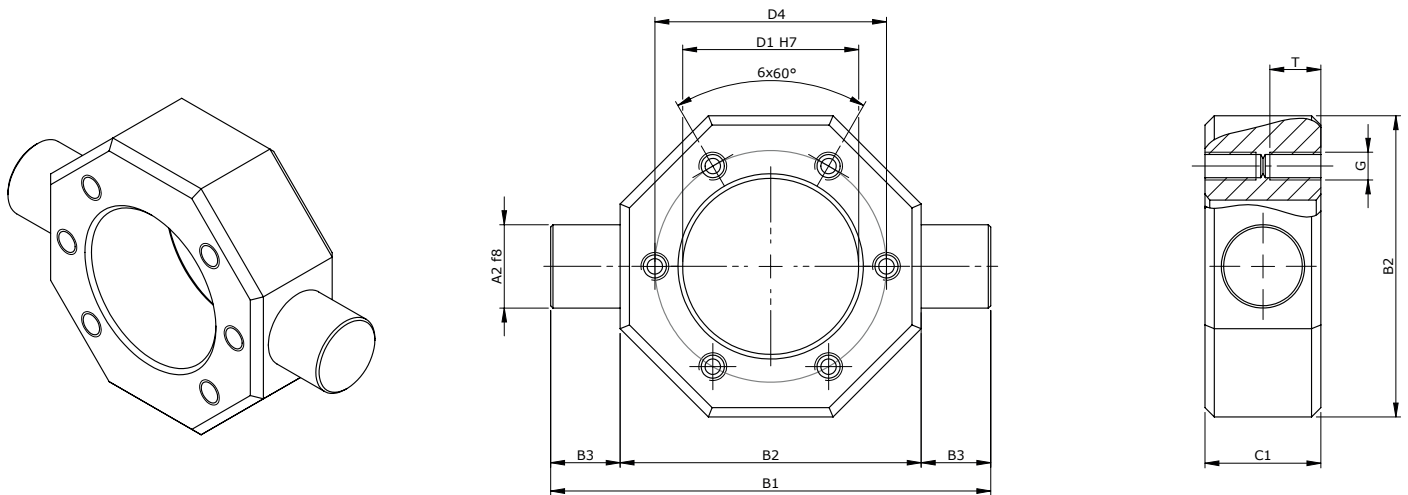

Size	Hole pattern ¹⁾	A2	B1	B2	B3	C1	D1	D4	G	T
KAR Tr 16x4/Tr 18x4/KGF-N 1605	3	12	70	50	10	20	28	38	M5	10
KAR KGF-D 1605/1610	1	12	70	50	10	20	28	38	M5	10
KAR Tr 20x4/Tr 24x5/KGF-N 2005	3	16	85	58	13.5	25	32	45	M6	12
KAR KGF-D 2005	1	16	85	58	13.5	25	36	47	M6	12
KAR KGF-N 2020/2050	3	18	95	65	15	25	35	50	M6	12
KAR Tr 30x6/KGF-N 2505	3	18	95	65	15	25	38	50	M6	12
KAR KGF-D 2505/2510/2520/2525/2550	1	18	95	65	15	25	40	51	M6	12
KAR Tr 36x6/KGF-N 3205	3	20	110	75	17.5	30	45	58	M6	12
KAR KGF-D 3205	1	25	125	85	20	30	45	58	M8	12
KAR KGF-N 3210/3240/4005	3	25	125	85	20	30	53	68	M6	12
KAR KGF-D 3210/3220	1	25	125	85	20	30	53	65	M8	12
KAR Tr 40x7/KGF-N 4010	3	30	140	100	20	40	63	78	M8	14
KAR KGF-D 4005/4010/4020/4040	2	30	140	100	20	40	63	78	M8	14
KAR Tr 50x8/KGF-N 5010	3	40	165	115	25	50	72	90	M10	16
KAR KGF-D 5010	2	40	165	115	25	50	72	93	M10	16
KAR KGF-D 5020	2	40	180	130	25	50	85	103	M10	16
KAR Tr 60x9/KGF-N 6310	3	40	180	130	25	50	85	105	M10	16

¹⁾ See catalogue illustration of nut hole pattern

Installation and maintenance

Trapezoidal screw drives TGT

Installation

Trapezoidal screw drives must be aligned carefully during installation – if suitable measuring equipment is not available, the screw drive should be turned through its entire length by hand before the drive unit is attached.

Variations in the amount of force required and/or marks on the external diameter of the spindle indicate alignment errors between the spindle axis and guide. In this case, the relevant mounting bolts should first be loosened and the screw drive should be turned through by hand. If the amount of force required is now constant throughout, the appropriate components should be aligned, otherwise the alignment error should be localised by loosening further mounting bolts.

Cover

By virtue of their design, trapezoidal screw drives are less sensitive to dirt than ball screw drives, particularly at low speeds (manual operation). Nevertheless motion drives, especially with plastic nuts, require protection against dirt in the same way as ball screw drives.

Lubrication

Oil lubrication

Used only in special cases for trapezoidal screw drives.

Grease lubrication

The usual lubrication method for trapezoidal screw drives. Lubrication intervals are governed by operating conditions; it is advisable to clean the spindle before greasing, especially by using high-performance lubricating machines.

Type of grease: ball bearing grease without solid lubricant. Parts ref. Neff Grease 2

Operating temperature

This depends on the type of nut used, the lubrication conditions and the user's requirements. Please consult us in the case of temperatures above 100 °C (plastic nuts 70 °C).

Wear

This can be checked manually: the nut should be replaced if the axial backlash with a single-start screw drive is more than 1/4 of the pitch.

Ball screw drives KGT

Installation

Ball screw drives are precision machine components; their installation requires specialist knowledge and suitable measuring equipment. Due to the low friction alignment errors can generally not be felt when the screw drive is turned by hand. Radial or eccentric forces must be taken up by external guides. Ball screw drives can absorb only axial forces. To avoid damage to the ball screw drive, limit switches and end stops must be installed in the machine.

Cover

Dirt that occurs during installation should be removed with paraffin, oil or petroleum ether. Cold cleaners and paint solvents are not permitted. Ball screw drives must be protected against dust, swarf, etc. even if equipped with wipers. Possible protective measures include:

- Bellows (suitable only for vertical installation without additional guide).
- Spiral spring cover.
- Telescopic tubes or sleeves (these take up a lot of axial space).

Lubrication

Proper lubrication is important for the achievement of the calculated service life of a ball screw drive, to prevent excessive warming and to ensure smooth, quiet running. The same lubricants are used for the KGT ball screw drives as for roller bearings.

Oil-mist lubrication

In the case of central lubrication with oil mist, note that only ball screw nuts without wipers may be used.

Oil lubrication

Die zugeführte Ölmenge sollte die Austragsverluste an den Abstreifern nicht überschreiten. (Sonst Ölumlaufschmierung).
Ölarten: Viskosität 25 bis 100 mm²/s bei 100 °C.

Grease lubrication

Add grease corresponding to the volume lost via the wipers (under normal operating conditions, it is sufficient to add grease every 200 to 300 hours). Experience shows that single lifetime lubrication is not sufficient because of the seepage of grease.

Grease type:

Roller bearing grease with no solid lubricant content. The first fill takes place at the supplier's with roller bearing grease. We recommend Neff Gear Grease 2/3 in the case of high mechanical stresses.

Operating temperature

The permissible operating temperature range for ball screw drives is between –30 °C and +80 °C, up to +110 °C for brief periods. A precondition for this is correct lubrication. The torque may increase by a factor of up to 10 at temperatures below –20 °C.

Worm Gear Screw Jacks M/J

The range includes a total of 11 worm gear screw jack models in two series: M 0 - M 5 with lifting capacities from 2.5 kN to 100 kN and J 1 - J 5 with static lifting capacities from 150 kN to 500 kN.

Stroke speed

Transmission Ratio H (high speed)

Worm gear screw jacks with trapezoidal-threaded spindle produce a stroke of 1 mm for each full revolution of the worm shaft. Accordingly the linear speed is 1500 mm per min at 1500 rpm. Worm gear screw jacks with a ball screw achieve 6000 mm/min, depending on size and pitch.

Transmission Ratio L (low speed)

Worm gear screw jacks with trapezoidal-threaded spindle produce a stroke of 0.25 mm for each full revolution of the worm shaft. Accordingly the linear speed is 375 mm per min at 1500 rpm.

Please note that higher speeds of travel can be achieved by using spindles with larger thread pitches or multi-start threads.

The worm gear screw jack's maximum drive speed of 3000 rpm must not be exceeded.

The higher efficiency of the ball screw drive also permits a longer duty cycle.

Tolerances and backlash

- The gearbox housings are machined on the six mounting sides. The tolerances conform to DIN ISO 2768-mH
- The axial backlash of the jack screw under alternating load is as follows:
 - Trapezoidal-threaded spindles: up to 0.4 mm (to DIN 103)
 - Ball screws: 0.07 mm
- The lateral backlash between the outside diameter of the spindle and the guide diameter is 0.2 mm.
- The backlash in the worm gears is $\pm 4^\circ$ for transmission ratio L and $\pm 1^\circ$ for transmission ratio H based on the drive shaft.
- Trapezoidal-threaded spindles are manufactured to a straightness of 0.3 – 1.5 mm/m, ball screws to a straightness of 0.02 mm/m over a length of 1000 mm and to the following pitch accuracies:
 - M 0 – M 5: 0.05 mm/300 mm length
 - J 1 – J 5: 0.2 mm/300 mm length.

Lateral forces on the screw jack.

Lateral forces can also be absorbed by our screw jacks. Please contact us.

Self-locking

The self-locking function depends on a variety of parameters:

- High pitches
- Different worm gear transmission ratios
- Lubrication
- Friction parameters
- Environmental influences, such as high or low temperatures, vibrations, etc.
- The mounting position

Versions with ball screw and TGS/KGS with high pitches are therefore not self-locking. Suitable brakes or braking motors must therefore be used in such cases. Self-locking is only conditionally available for smaller pitches (single-start). Self-locking in individual cases on enquiry

Version N

The lifting spindle is driven by a nut thread in the worm gear via the worm shaft. Protection against twisting is achieved by the on-site fastening of the spindle.

Version VK

The lifting spindle is driven by a nut thread in the worm gear via the worm shaft. Protection against twisting is achieved by a square protective tube on the gear side.

Version VP

The lifting spindle is driven by a nut thread in the worm gear via the worm shaft. Protection against twisting is achieved by a feather key in the bearing cover of the gearbox and a milled groove in the spindle.

Version R

The lifting spindle is made to rotate by the worm shaft via the worm gear with a feather key connection to the spindle. The rotary motion of the spindle is converted into a linear motion by the on-site anti-twist securing of the travelling nut.

Anti-unscrewing device A

The anti-unscrewing device prevents the spindle from screwing out of the gearbox. It is standard equipment in the ball screw versions N and V and is available as an option in worm gear screw jacks with trapezoidal-threaded spindles.

The anti-unscrewing device cannot be used as a fixed stop.

Special versions

In addition to the extensive standard range, NEFF can also supply anticlockwise, multi-start and special material worm gear screw jacks on enquiry.

General technical data

Trapezoidal-thread spindle

		M 0	M 1	M 2	M 3	M 4	M 5	J 1	J 2	J 3	J 4	J 5
Maximum lifting force [kN] ¹⁾		2.5	5	10	25	50	100	150	200	250	350	500
Diameter and pitch [mm]		14 x 4	18 x 4	20 x 4	30 x 6	40 x 7	55 x 9	60 x 9	70 x 10	80 x 10	100 x 10	120 x 14
Stroke per revolution of the drive shaft [mm]	Transmission ratio. H ²⁾	1	1	1	1	1	1	1	1	1	1	1
	Transmission ratio. L ²⁾	0.25	0.25	0.25	0.25	0.25	0.25	0.25	0.25	0.25	0.25	0.25
Transmission ratio.	Transmission ratio. H ²⁾	4:1	4:1	4:1	6:1	7:1	9:1	9:1	10:1	10:1	10:1	14:1
	Transmission ratio. L ²⁾	16:1	16:1	16:1	24:1	28:1	36:1	36:1	40:1	40:1	40:1	56:1
Efficiency [%] ³⁾	Transmission ratio. H ²⁾	35	31	29	29	26	24	23	22	20	19	19
	Transmission ratio. L ²⁾	27	25	23	23	21	19	18	17	15	15	15
Weight [kg] (without stroke)		0.6	1.2	2.1	6	17	32	41	57	57	85	160
Weight [kg per 100 mm stroke]		0.1	0.26	0.42	1.14	1.67	3.04	3.1	4.45	6.13	7.9	11.5
Idling torque [Nm]	H	0.02	0.04	0.11	0.15	0.35	0.84	0.88	1.28	1.32	1.62	1.98
	L	0.016	0.03	0.10	0.12	0.25	0.51	0.57	0.92	0.97	1.10	1.42
Housing material		G – AL up to M3					GGG – 40					

Ball screw spindle

		M 0	M 1	M 2	M 3	M 4		M 5	J 3	
Maximum lifting force [kN] ¹⁾		2	5	10	12.5	22	42	65	78	
Diameter and pitch [mm]		1205	1605	2005	2505	4005	4010	5010	8010	
Stroke per revolution of the drive shaft [mm]	Transmission ratio. H ²⁾	1.25	1.25	1.25	0.83	0.71	1.43	1.1	1	
	Transmission ratio. L ²⁾	0.31	0.31	0.31	0.21	0.18	0.36	0.28	0.25	
Transmission ratio.	Transmission ratio. H ²⁾	4:1	4:1	4:1	6:1	7:1		9:1	10:1	
	Transmission ratio. L ²⁾	16:1	16:1	16:1	24:1	28:1		36:1	40:1	
Efficiency [%] ³⁾	Transmission ratio. H ²⁾	60	57	56	55	53	56	47	45	
	Transmission ratio. L ²⁾	48	46	44	43	43	45	37	34	
Weight [kg] (without stroke)		0.6	1.3	2.3	7	19		35	63	
Weight [kg per 100 mm stroke]		0.09	0.26	0.42	1.14	1.67		3.04	6.13	
Idling torque [Nm]	H	0.02	0.04	0.11	0.15	0.35		0.84	1.32	
	L	0.016	0.03	0.10	0.12	0.25		0.51	0.97	
Housing material		G – AL up to M3					GGG – 40			

¹⁾ Dependent on stroke speed, duty cycle, etc.

²⁾ H = high travel speed,
L = low travel speed

³⁾ The specified efficiency values are average values

Dimensions, version N

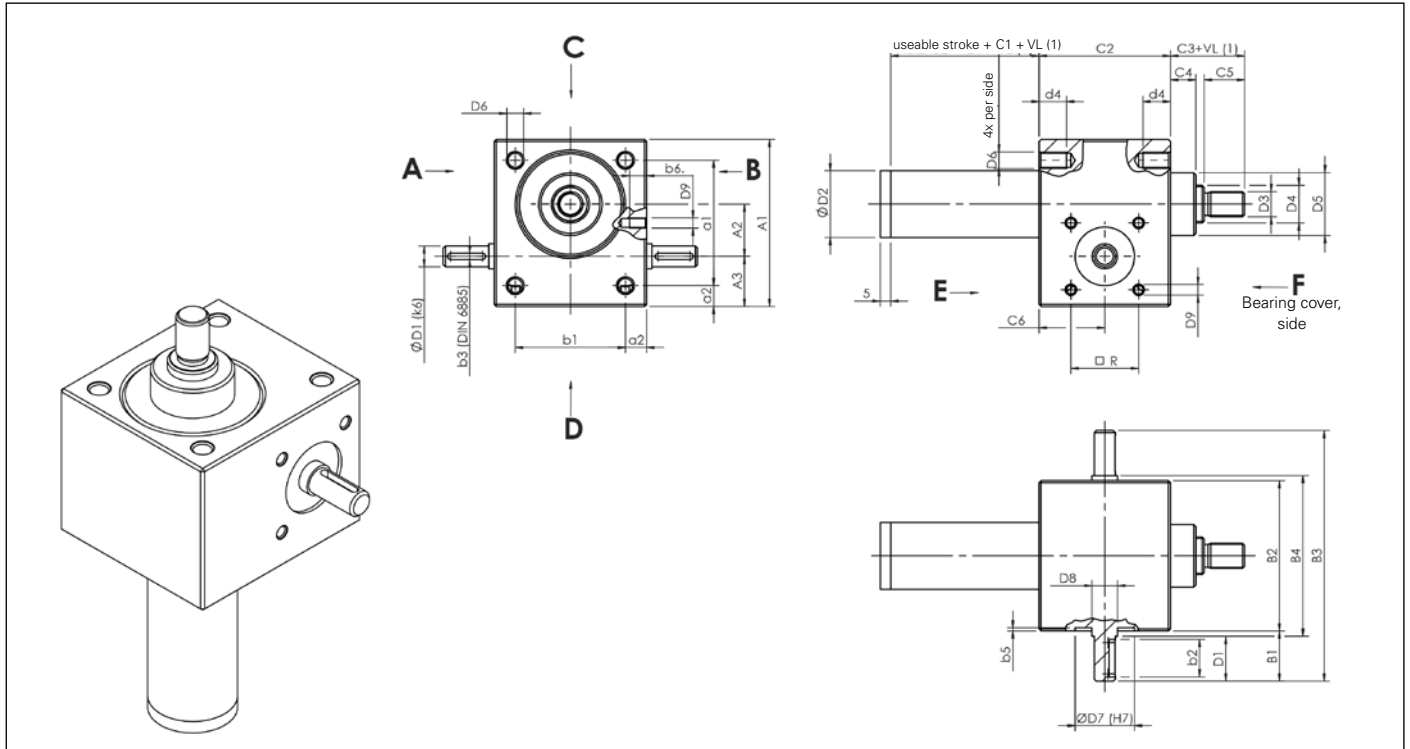

Size	Dimensions [mm]																
	A ₁	A ₂	A ₃	a ₁	a ₂	B ₁	B ₂	B ₃	B ₄	b ₁	b ₂	b ₃	b ₅	C ₁ TR ⁽²⁾	C ₁ KGT/AS ⁽³⁾	C ₂	C ₃
M 0	60	20	18	48	6	21	50	92	52	38	14	3	1.5	20	50	50	27
M 1	80	25	24	60	10	24	72	120	77	52	18	3	1.5	20	50	62	35
M 2	100	32	28	78	11	27.5	85	140	90	63	20	5	1.5	30	60	75	45
M 3	130	45	31	106	12	45	105	195	110	81	36	5	2	35	70	82	50
M 4	180	63	39	150	15	47.5	145	240	150	115	36	6	2	40	90	117	65
M 5	200	71	46	166	17	67.5	165	300	170	131	56	8	2.5	55	100	160	95
J 1	210	71	49	170	20	65	195	325	200	155	56	8	8	55	100	175	95
J 2	240	80	60	190	25	67.5	220	355	225	170	56	8	8	60	110	165	110
J 3 (M6)	240	80	60	190	25	67.5	220	355	225	170	56	8	8	60	110	165	110
J 4 (M7)	290	100	65	230	30	65	250	380	255	190	56	10	8	65	150	220	140
J 5 (M8)	360	135	75	290	35	100	300	500	305	230	90	14	8	100	145	266	200

Size	Dimensions [mm]														
	C ₄	C ₅	C ₆	D _{1k6}	D ₂	D ₃	d ₄	D ₄ Tr	D ₄ KGT	D ₅	D ₆	D ₇ ^{H7}	D ₈	D ₉ x b ₆	TK □ R
M 0	12	12	25	9 x 20	28	M8	12	Tr14 x 4	1205	26	M6	22	10	(M5 x 6)*	24
M 1	12	19	31	10 x 21.5	32	M12	13	Tr18 x 4	1605	30	M8	32	12	M5 x 6	32
M 2	18	20	37.5	14 x 25	40	M14	15	Tr20 x 4	2005	38.7	M8	35	15	M6 x 10	35
M 3	23	22	41	16 x 42.5	50	M20	15	Tr30 x 6	2505	46	M10	40	17	M8 x 10	44
M 4	32	29	58.5	20 x 45	65	M30	16	Tr40 x 7	4005/4010	60	M12	52	25	M10 x 14	55
M 5	40	48	80	25 x 65	90	M36	30	Tr55 x 9	5010	85	M20	62	28	M12 x 16	70
J 1	40	48	87.5	25 x 62.5	95	M48 x 2	40	Tr60 x 9	—	90	M24	72	28	M12 x 16	70
J 2	40	58	82.5	30 x 65	110	M56 x 2	45	Tr70 x 10	—	105	M30	80	32	M12 x 18	(80)
J 3 (M6)	40	58	82.5	30 x 65	125	M64 x 3	45	Tr80 x 10	8010	120	M30	80	32	M12 x 18	(80)
J 4 (M7)	50	78	110	35 x 62.5	150	M72 x 3	54	Tr100 x 10	—	145	M36	85	40	M16 x 30	(80)
J 5 (M8)	60	118	133	48 x 97.5	180	M100 x 3	80	Tr120 x 14	—	170	M42	90	50	M16 x 40	(115)

* Tapped bore for motor adaptor flange on attachment side A and B standard only centralised. Tapped bore on enquiry.
Note: subject to technical changes.

(1) VL: Spindle extension
(2) Mass C1 for screw jacks with trapezoidal screw drive
(3) Mass C1 for screw jacks with ball screw drive or securing against hollowing

Dimensions, version VK

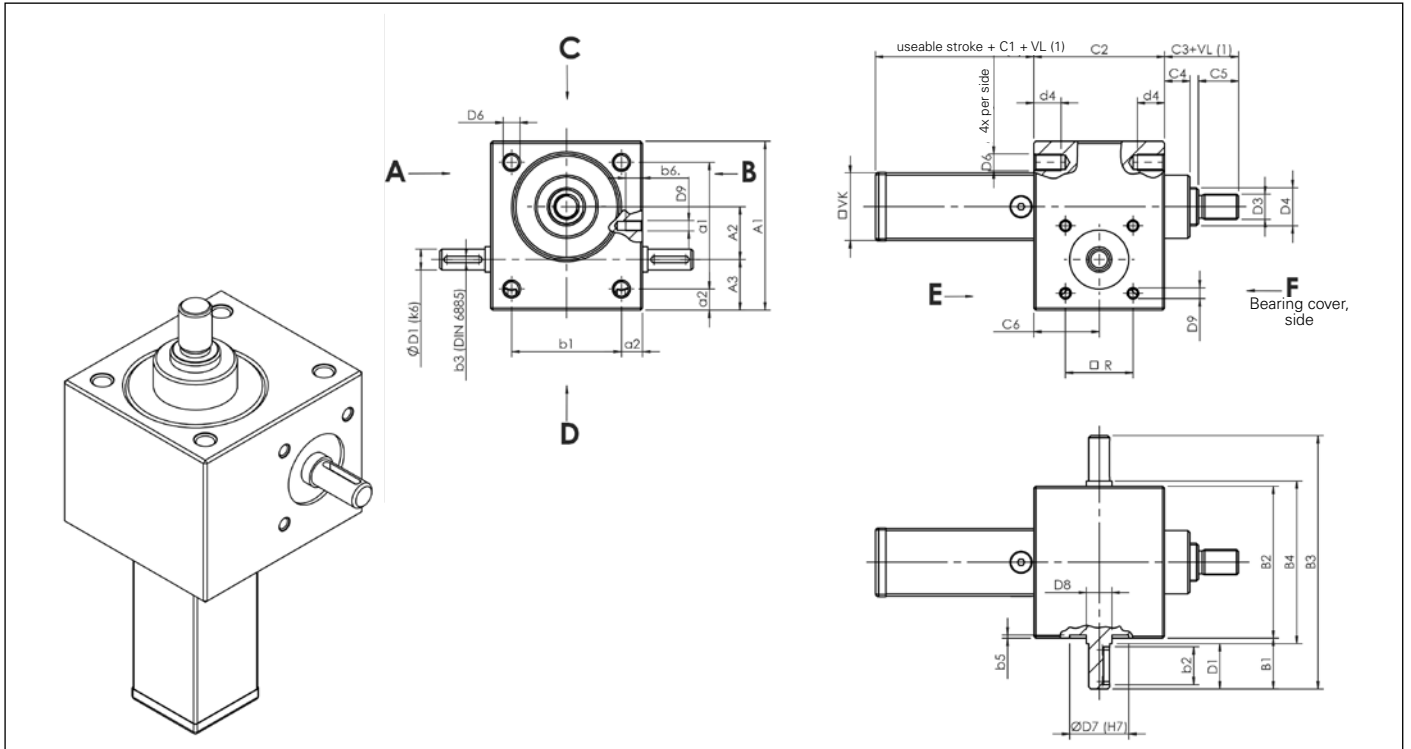

Size	Dimensions [mm]																
	A ₁	A ₂	A ₃	a ₁	a ₂	B ₁	B ₂	B ₃	B ₄	b ₁	b ₂	b ₃	b ₅	C ₁ TR ⁽²⁾	C ₁ KGT/AS ⁽³⁾	C ₂	C ₃
M 0	60	20	18	48	6	21	50	92	52	38	14	3	1.5	20	50	50	27
M 1	80	25	24	60	10	24	72	120	77	52	18	3	1.5	20	50	62	35
M 2	100	32	28	78	11	27.5	85	140	90	63	20	5	1.5	30	60	75	45
M 3	130	45	31	106	12	45	105	195	110	81	36	5	2	35	70	82	50
M 4	180	63	39	150	15	47.5	145	240	150	115	36	6	2	40	90	117	65
M 5	200	71	46	166	17	67.5	165	300	170	131	56	8	2.5	55	100	160	95
J 1	210	71	49	170	20	65	195	325	200	155	56	8	8	55	100	175	95
J 2	240	80	60	190	25	67.5	220	355	225	170	56	8	8	60	110	165	110
J 3 (M6)	240	80	60	190	25	67.5	220	355	225	170	56	8	8	60	110	165	110
J 4 (M7)	290	100	65	230	30	65	250	380	255	190	56	10	8	65	150	220	140
J 5 (M8)	360	135	75	290	35	100	300	500	305	230	90	14	8	100	145	266	200

Size	Dimensions [mm]															
	C ₄	C ₅	C ₆	D _{1k6}	D ₃	d ₄	D ₄ Tr	D ₄ KGT	D ₅	D ₆	D ₇ ^{H7}	D ₈	D ₉ x b ₆ *	TK □ R	V-KGT	
M 0	12	12	25	9 x 20	M8	12	Tr14 x 4	1205	26	M6	22	10	(M5 x 6)*	24	30 x 30	
M 1	12	19	31	10 x 21.5	M12	13	Tr18 x 4	1605	30	M8	32	12	M5 x 6	32	35 x 35	
M 2	18	20	37.5	14 x 25	M14	15	Tr20 x 4	2005	38.7	M8	35	15	M6 x 10	35	40 x 40	
M 3	23	22	41	16 x 42.5	M20	15	Tr30 x 6	2505	46	M10	40	17	M8 x 10	44	50 x 50	
M 4	32	29	58.5	20 x 45	M30	16	Tr40 x 7	4005/4010	60	M12	52	25	M10 x 14	55	70 x 70	
M 5	40	48	80	25 x 65	M36	30	Tr55 x 9	5010	85	M20	62	28	M12 x 16	70	90 x 90	
J 1	40	48	87.5	25 x 62.5	M48 x 2	40	Tr60 x 9	—	90	M24	72	28	M12 x 16	70	90 x 90	
J 2	40	58	82.5	30 x 65	M56 x 2	45	Tr70 x 10	—	105	M30	80	32	M12 x 18	(80)	110 x 110	
J 3 (M6)	40	58	82.5	30 x 65	M64 x 3	45	Tr80 x 10	8010	120	M30	80	32	M12 x 18	(80)	125 x 125	
J 4 (M7)	50	78	110	35 x 62.5	M72 x 3	54	Tr100 x 10	—	145	M36	85	40	M16 x 30	(80)	150 x 150	
J 5 (M8)	60	118	133	48 x 97.5	M100 x 3	80	Tr120 x 14	—	170	M42	90	50	M16 x 40	(115)	180 x 180	

* Tapped bore for motor adaptor flange on attachment side A and B standard only centralised. Tapped bore on enquiry. Note: subject to technical changes.

(1) VL: Spindle extension

(2) Mass C1 for screw jacks with trapezoidal screw drive

(3) Mass C1 for screw jacks with ball screw drive or securing against hollowing

Dimensions, version VP

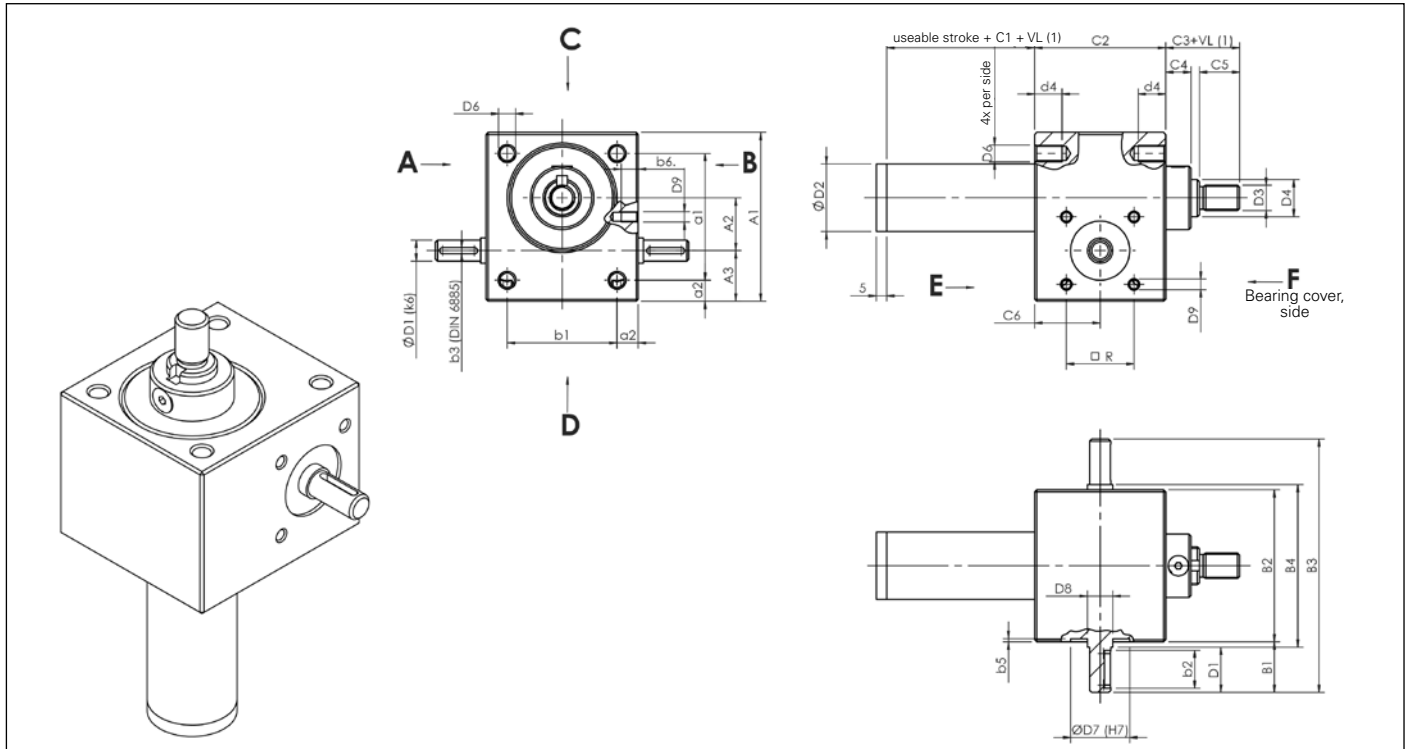

Size	Dimensions [mm]																
	A ₁	A ₂	A ₃	a ₁	a ₂	B ₁	B ₂	B ₃	B ₄	b ₁	b ₂	b ₃	b ₅	C _{1,TR} ⁽²⁾	C _{1,KGT/AS} ⁽³⁾	C ₂	C ₃
M 0	60	20	18	48	6	21	50	92	52	38	14	3	1.5	20	50	50	27
M 1	80	25	24	60	10	24	72	120	77	52	18	3	1.5	20	50	62	35
M 2	100	32	28	78	11	27.5	85	140	90	63	20	5	1.5	30	60	75	45
M 3	130	45	31	106	12	45	105	195	110	81	36	5	2	35	70	82	50
M 4	180	63	39	150	15	47.5	145	240	150	115	36	6	2	40	90	117	65
M 5	200	71	46	166	17	67.5	165	300	170	131	56	8	2.5	55	100	160	95
J 1	210	71	49	170	20	65	195	325	200	155	56	8	8	55	100	175	95
J 2	240	80	60	190	25	67.5	220	355	225	170	56	8	8	60	110	165	110
J 3	240	80	60	190	25	67.5	220	355	225	170	56	8	8	60	110	165	110
J 4	290	100	65	230	30	65	250	380	255	190	56	10	8	65	150	220	140
J 5	360	135	75	290	35	100	300	500	305	230	90	14	8	100	145	266	200

Size	Dimensions [mm]														
	C ₄	C ₅	C ₆	D _{1k6}	D ₂	D ₃	d ₄	D _{4,Tr}	D _{4,KGT}	D ₅	D ₆	D ₇ ^{H7}	D ₈	D ₉ x b ₆	TK □ R
M 0	12	12	25	9 x 20	28	M8	12	Tr14 x 4	1205	26	M6	22	10	(M5 x 6)*	24
M 1	12	19	31	10 x 21.5	32	M12	13	Tr18 x 4	1605	30	M8	32	12	M5 x 6	32
M 2	18	20	37.5	14 x 25	40	M14	15	Tr20 x 4	2005	38.7	M8	35	15	M6 x 10	35
M 3	23	22	41	16 x 42.5	50	M20	15	Tr30 x 6	2505	46	M10	40	17	M8 x 10	44
M 4	32	29	58.5	20 x 45	65	M30	16	Tr40 x 7	4005/4010	60	M12	52	25	M10 x 14	55
M 5	40	48	80	25 x 65	90	M36	30	Tr55 x 9	5010	85	M20	62	28	M12 x 16	70
J 1	40	48	87.5	25 x 62.5	95	M48 x 2	40	Tr60 x 9	–	90	M24	72	28	M12 x 16	70
J 2	40	58	82.5	30 x 65	110	M56 x 2	45	Tr70 x 10	–	105	M30	80	32	M12 x 18	(80)
J 3 (M6)	40	58	82.5	30 x 65	125	M64 x 3	45	Tr80 x 10	8010	120	M30	80	32	M12 x 18	(80)
J 4 (M7)	50	78	110	35 x 62.5	150	M72 x 3	54	Tr100 x 10	–	145	M36	85	40	M16 x 30	(80)
J 5 (M8)	60	118	133	48 x 97.5	180	M100 x 3	80	Tr120 x 14	–	170	M42	90	50	M16 x 40	(115)

* Tapped bore for motor adaptor flange on attachment side A and B standard only centralised. Tapped bore on enquiry.
Note: subject to technical changes.

(1) VL: Spindle extension
(2) Mass C1 for screw jacks with trapezoidal screw drive
(3) Mass C1 for screw jacks with ball screw drive or securing against hollowing

Dimensions, version R

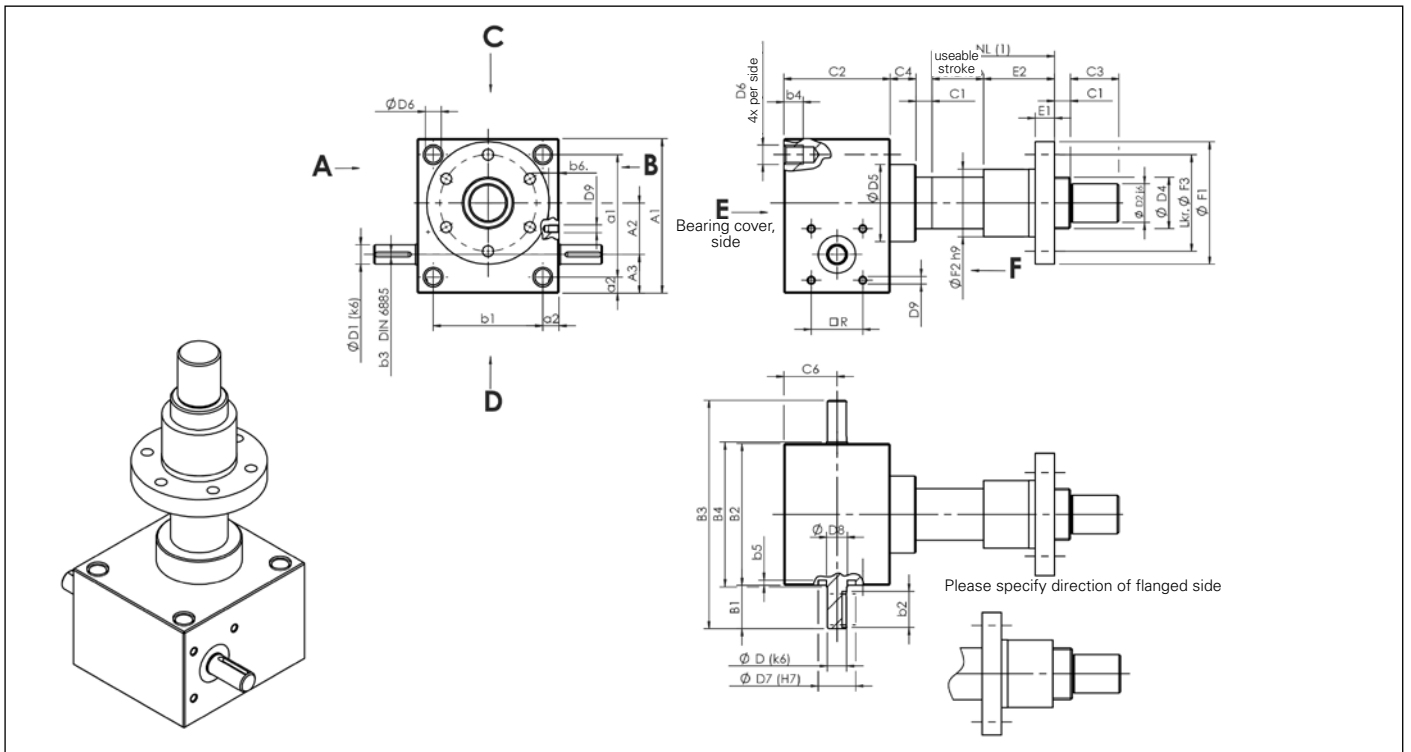

Size	Dimensions [mm]																		
	A ₁	A ₂	A ₃	a ₁	a ₂	B ₁	B ₂	B ₃	B ₄	b ₁	b ₂	b ₃	b ₄	b ₅	C ₁	C ₂	C ₃	C ₄	C ₆
M 0	60	20	18	48	6	21	50	92	52	38	14	3	12	1.5	10	50	12	12	25
M 1	80	25	24	60	10	24	72	120	77	52	18	3	13	1.5	12	62	15	12	31
M 2	100	32	28	78	11	27.5	85	140	90	63	20	5	15	1.5	15	75	20	18	37.5
M 3	130	45	31	106	12	45	105	195	110	81	36	5	15	2	20	82	25	23	41
M 4	180	63	39	150	15	47.5	145	240	150	115	36	6	16	2	25	117	30	32	58.5
M 5	200	71	46	166	17	67.5	165	300	170	131	56	8	30	2.5	25	160	45	40	80
J 1	210	71	49	170	20	65	195	325	200	155	56	8	40	8	25	175	55	40	87.5
J 2	240	80	60	190	25	67.5	220	355	225	170	56	8	45	8	25	165	70	40	82.5
J 3	240	80	60	190	25	67.5	220	355	225	170	56	8	45	8	25	165	75	40	82.5
J 4	290	100	65	230	30	65	250	380	255	190	56	10	54	8	25	220	100	50	110
J 5	360	135	75	290	35	100	300	500	305	230	90	14	80	8	30	266	120	60	133

Size	Dimensions [mm]															
	D _{1k6}	D _{2j6}	D _{4TR}	D _{4KGT}	D ₅	D ₆	D _{7H7}	D ₈	D ₉ x b ₆ *	□ R	E ₁	E ₂	F ₁	F ₂	F ₃	F ₄
M 0	9 x 20	8	Tr14 x 4	1205	26	M6	22	10	M5 x 6*	24	12	35	48	28	38	6
M 1	10 x 21.5	12	Tr18 x 4	1605	30	M8	32	12	(M5 x 6)*	32	12/12	44/44	48/48	28/28	38/38	6/6
M 2	14 x 25	15	Tr20 x 4	2005	36.1	M8	32	15	M6 x 10	35	12/12	44/44	55/55	32/32	45/45	7/7
M 3	16 x 42.5	20	Tr30 x 6	2505	46	M10	40	17	M8 x 10	44	14/14	46/46	62/62	38/38	50/50	7/7
M 4	20 x 45	25	Tr40 x 7	4005/4010	60	M12	52	25	M10 x 14	55	16/16	73/59	95/80	63/53	78/68	9/7
M 5	25 x 65	40	Tr55 x 9	5010	85	M20	62	28	M12 x 16	70	18/18	97/97	110/110	72/72	90/90	11/11
J 1	25 x 62.5	45	Tr60 x 9	—	90	M24	72	28	M12 x 16	70	20	99	125	85	105	11
J 2	30 x 65	55	Tr70 x 10	—	105.2	M30	80	32	M12 x 18	(80)	30	100	180	95	140	17
J 3 (M 6)	30 x 65	60	Tr80 x 10	8010	120	M30	80	32	M12 x 18	(80)	30/22	110/101	190/145	105/105	150/125	17/14
J 4 (M 7)	35 x 62.5	80	Tr100 x 10	—	145	M36	85	40	M16 x 30	(80)	35	130	240	130	185	25
J 5 (M 8)	48 x 97.5	95	Tr120 x 14	—	170	M42	90	50	M16 x 40	(115)	40	160	300	160	230	28

* Tapped bore for motor adaptor flange on attachment side A and B standard only centralised. Tapped bore on enquiry.

Note: subject to technical changes.

(1) NL: usable stroke length

Dimensions

Version N/VK/VP with limit switch attachment

Limit switch with roller plunger:

Actuating cam 30° according to DIN 69639

- Minimum actuation stroke: 2.6 mm +/- 0.5mm
- Differential stroke: 0.85 mm +/- 0.25mm
- Minimum switch-on force: 1 N
- Start-up speed: 0.001 to 0.1 m/s
- Connection: 5-core (brown/blue: normally open; black/black: normally closed; green/yellow: earth conductor)
- Switching capacity: NFC 63146

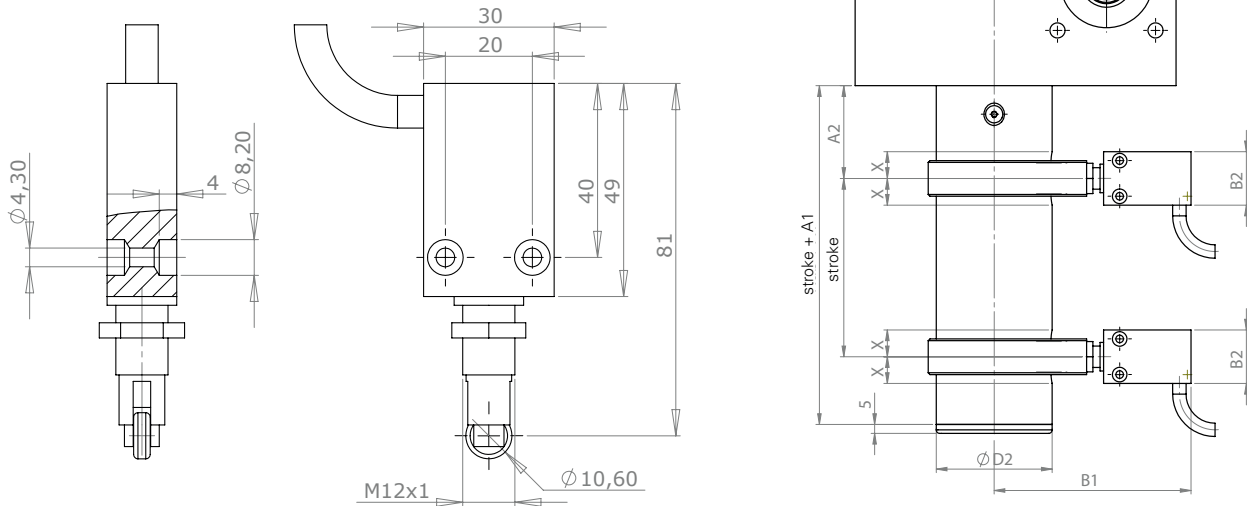

Size	Dimensions [mm]						
	A ₁	A ₂	B ₁	B ₂	M	X	Ø D2
M0	65	27	94	30	M12x1	±10	28
M1	65	27	96	30	M12x1	±10	32
M2	65	32	100	30	M12x1	±10	40
M3	75	41	105	30	M12x1	±10	50
M4	90	52	113	30	M12x1	±10	65
M5	100	60	125	30	M12x1	±10	90
J1	100	60	125	30	M12x1	±10	95
J2	on enquiry						
J3							
J4							
J5							

□ Duty cycle 10-20%

▒ Duty cycle < 10%

■ only static permissible

Performance table

for worm gear screw jacks M/J

M0-TR 14x4

n [rpm]	Stroke speed [m/min]		F=2.5 [kN]				F=2 [kN]				F=1.5 [kN]				F=1 [kN]				F=0.75 [kN]				F=0.5 [kN]				F=0.25 [kN]			
			4:1		16:1		4:1		16:1		4:1		16:1		4:1		16:1		4:1		16:1		4:1		16:1		4:1		16:1	
	H	L	Nm	kW	Nm	kW	Nm	kW	Nm	kW	Nm	kW	Nm	kW	Nm	kW	Nm	kW	Nm	kW	Nm	kW	Nm	kW	Nm	kW	Nm	kW	Nm	kW
1500	1.5	0.375	1.2	0.18	0.4	0.1	0.9	0.15	0.3	0.1	0.7	0.1	0.2	0.1	0.5	0.1	0.2	0.1	0.4	0.1	0.1	0.1	0.2	0.1	0.1	0.1	0.1	0.1	0	0.1
1000	1	0.25	1.2	0.12	0.4	0.1	0.9	0.1	0.3	0.1	0.7	0.1	0.2	0.1	0.5	0.1	0.2	0.1	0.4	0.1	0.1	0.1	0.2	0.1	0.1	0.1	0.1	0.1	0	0.1
750	0.75	0.188	1.2	0.1	0.4	0.1	0.9	0.1	0.3	0.1	0.7	0.1	0.2	0.1	0.5	0.1	0.2	0.1	0.4	0.1	0.1	0.1	0.2	0.1	0.1	0.1	0.1	0.1	0	0.1
600	0.6	0.15	1.2	0.1	0.4	0.1	0.9	0.1	0.3	0.1	0.7	0.1	0.2	0.1	0.5	0.1	0.2	0.1	0.4	0.1	0.1	0.1	0.2	0.1	0.1	0.1	0.1	0.1	0	0.1
500	0.5	0.125	1.2	0.1	0.4	0.1	0.9	0.1	0.3	0.1	0.7	0.1	0.2	0.1	0.5	0.1	0.2	0.1	0.4	0.1	0.1	0.1	0.2	0.1	0.1	0.1	0.1	0.1	0	0.1
300	0.3	0.075	1.2	0.1	0.4	0.1	0.9	0.1	0.3	0.1	0.7	0.1	0.2	0.1	0.5	0.1	0.2	0.1	0.4	0.1	0.1	0.1	0.2	0.1	0.1	0.1	0.1	0.1	0	0.1
100	0.1	0.025	1.2	0.1	0.4	0.1	0.9	0.1	0.3	0.1	0.7	0.1	0.2	0.1	0.5	0.1	0.2	0.1	0.4	0.1	0.1	0.1	0.2	0.1	0.1	0.1	0.1	0.1	0	0.1
50	0.05	0.013	1.2	0.1	0.4	0.1	0.9	0.1	0.3	0.1	0.7	0.1	0.2	0.1	0.5	0.1	0.2	0.1	0.4	0.1	0.1	0.1	0.2	0.1	0.1	0.1	0.1	0.1	0	0.1

M1-TR 18x4

n [rpm]	Stroke speed [m/min]		F=5 [kN]				F=4 [kN]				F=3 [kN]				F=2.5 [kN]				F=2 [kN]				F=1.5 [kN]				F=1 [kN]			
			4:1		16:1		4:1		16:1		4:1		16:1		4:1		16:1		4:1		16:1		4:1		16:1		4:1		16:1	
	H	L	Nm	kW	Nm	kW	Nm	kW	Nm	kW	Nm	kW	Nm	kW	Nm	kW	Nm	kW	Nm	kW	Nm	kW	Nm	kW	Nm	kW	Nm	kW	Nm	kW
1500	1.5	0.375	2.7	0.42	0.9	0.1	2.1	0.33	0.7	0.1	1.6	0.25	0.5	0.1	1.3	0.21	0.4	0.1	1.1	0.2	0.3	0.1	0.8	0.1	0.3	0.1	0.5	0.1	0.2	0.1
1000	1	0.25	2.7	0.28	0.9	0.1	2.1	0.22	0.7	0.1	1.6	0.17	0.5	0.1	1.3	0.14	0.4	0.1	1.1	0.1	0.3	0.1	0.8	0.1	0.3	0.1	0.5	0.1	0.2	0.1
750	0.75	0.188	2.7	0.21	0.9	0.1	2.1	0.17	0.7	0.1	1.6	0.13	0.5	0.1	1.3	0.1	0.4	0.1	1.1	0.1	0.3	0.1	0.8	0.1	0.3	0.1	0.5	0.1	0.2	0.1
600	0.6	0.15	2.7	0.17	0.9	0.1	2.1	0.13	0.7	0.1	1.6	0.1	0.5	0.1	1.3	0.1	0.4	0.1	1.1	0.1	0.3	0.1	0.8	0.1	0.3	0.1	0.5	0.1	0.2	0.1
500	0.5	0.125	2.7	0.14	0.9	0.1	2.1	0.1	0.7	0.1	1.6	0.1	0.5	0.1	1.3	0.1	0.4	0.1	1.1	0.1	0.3	0.1	0.8	0.1	0.3	0.1	0.5	0.1	0.2	0.1
300	0.3	0.075	2.7	0.1	0.9	0.1	2.1	0.1	0.7	0.1	1.6	0.1	0.5	0.1	1.3	0.1	0.4	0.1	1.1	0.1	0.3	0.1	0.8	0.1	0.3	0.1	0.5	0.1	0.2	0.1
100	0.1	0.025	2.7	0.1	0.9	0.1	2.1	0.1	0.7	0.1	1.6	0.1	0.5	0.1	1.3	0.1	0.4	0.1	1.1	0.1	0.3	0.1	0.8	0.1	0.3	0.1	0.5	0.1	0.2	0.1
50	0.05	0.013	2.7	0.1	0.9	0.1	2.1	0.1	0.7	0.1	1.6	0.1	0.5	0.1	1.3	0.1	0.4	0.1	1.1	0.1	0.3	0.1	0.8	0.1	0.3	0.1	0.5	0.1	0.2	0.1

M2-TR 20x4

n [rpm]	Stroke speed [m/min]		F=10 [kN]				F=8 [kN]				F=6 [kN]				F=4 [kN]				F=3 [kN]				F=2 [kN]				F=1 [kN]			
			4:1		16:1		4:1		16:1		4:1		16:1		4:1		16:1		4:1		16:1		4:1		16:1		4:1		16:1	
	H	L	Nm	kW	Nm	kW	Nm	kW	Nm	kW	Nm	kW	Nm	kW	Nm	kW	Nm	kW	Nm	kW	Nm	kW	Nm	kW	Nm	kW	Nm	kW	Nm	kW
1500	1.5	0.375	5.7	0.89	1.9	0.3	4.5	0.71	1.5	0.24	3.4	0.54	1.1	0.18	2.3	0.36	0.8	0.1	1.7	0.27	0.6	0.1	1.1	0.2	0.4	0.1	0.6	0.1	0.2	0.1
1000	1	0.25	5.7	0.6	1.9	0.2	4.5	0.48	1.5	0.16	3.4	0.36	1.1	0.12	2.3	0.24	0.8	0.1	1.7	0.18	0.6	0.1	1.1	0.1	0.4	0.1	0.6	0.1	0.2	0.1
750	0.75	0.188	5.7	0.45	1.9	0.15	4.5	0.36	1.5	0.12	3.4	0.27	1.1	0.1	2.3	0.18	0.8	0.1	1.7	0.13	0.6	0.1	1.1	0.1	0.4	0.1	0.6	0.1	0.2	0.1
600	0.6	0.15	5.7	0.36	1.9	0.12	4.5	0.29	1.5	0.1	3.4	0.21	1.1	0.1	2.3	0.14	0.8	0.1	1.7	0.1	0.6	0.1	1.1	0.1	0.4	0.1	0.6	0.1	0.2	0.1
500	0.5	0.125	5.7	0.3	1.9	0.1	4.5	0.24	1.5	0.1	3.4	0.18	1.1	0.1	2.3	0.12	0.8	0.1	1.7	0.1	0.6	0.1	1.1	0.1	0.4	0.1	0.6	0.1	0.2	0.1
300	0.3	0.075	5.7	0.18	1.9	0.1	4.5	0.14	1.5	0.1	3.4	0.11	1.1	0.1	2.3	0.1	0.8	0.1	1.7	0.1	0.6	0.1	1.1	0.1	0.4	0.1	0.6	0.1	0.2	0.1
100	0.1	0.025	5.7	0.1	1.9	0.1	4.5	0.1	1.5	0.1	3.4	0.1	1.1	0.1	2.3	0.1	0.8	0.1	1.7	0.1	0.6	0.1	1.1	0.1	0.4	0.1	0.6	0.1	0.2	0.1
50	0.05	0.013	5.7	0.1	1.9	0.1	4.5	0.1	1.5	0.1	3.4	0.1	1.1	0.1	2.3	0.1	0.8	0.1	1.7	0.1	0.6	0.1	1.1	0.1	0.4	0.1	0.6	0.1	0.2	0.1

M3-Tr 30x6

n [rpm]	Stroke speed [m/min]		F=25 [kN]				F=20 [kN]				F=15 [kN]				F=10 [kN]				F=5 [kN]				F=2.5 [kN]				F=1 [kN]			
			6:1		24:1		6:1		24:1		6:1		24:1		6:1		24:1		6:1		24:1		6:1		24:1		6:1		24:1	
	H	L	Nm	kW	Nm	kW	Nm	kW	Nm	kW	Nm	kW	Nm	kW	Nm	kW	Nm	kW	Nm	kW	Nm	kW	Nm	kW	Nm	kW	Nm	kW	Nm	kW
1500	1.5	0.375	14.7	2.31	5.2	0.82	11.8	1.85	4.2	0.66	8.8	1.39	3.1	0.49	5.9	0.93	2.1	0.33	2.9	0.46	1	0.2	1.5	0.2	0.5	0.1	0.6	0.1	0.2	0.1
1000	1	0.25	14.7	1.54	5.2	0.55	11.8	1.23	4.2	0.44	8.8	0.93	3.1	0.33	5.9	0.62	2.1	0.22	2.9	0.31	1	0.1	1.5	0.2	0.5	0.1	0.6	0.1	0.2	0.1
750	0.75	0.188	14.7	1.16	5.2	0.41	11.8	0.93	4.2	0.33	8.8	0.69	3.1	0.25	5.9	0.46	2.1	0.16	2.9	0.23	1	0.1	1.5	0.1	0.5	0.1	0.6	0.1	0.2	0.1
600	0.6	0.15	14.7	0.93	5.2	0.33	11.8	0.74	4.2	0.26	8.8	0.56	3.1	0.2	5.9	0.37	2.1	0.13	2.9	0.19	1	0.1	1.5	0.1	0.5	0.1	0.6	0.1	0.2	0.1
500	0.5	0.125	14.7	0.77	5.2	0.27	11.8	0.62	4.2	0.22	8.8	0.46	3.1	0.16	5.9	0.31	2.1	0.11	2.9	0.15	1	0.1	1.5	0.1	0.5	0.1	0.6	0.1	0.2	0.1
300	0.3	0.075	14.7	0.46	5.2	0.16	11.8	0.37	4.2	0.13	8.8	0.28	3.1	0.1	5.9	0.19	2.1	0.1	2.9	0.1	1	0.1	1.5	0.1	0.5	0.1	0.6	0.1	0.2	0.1
100	0.1	0.025	14.7	0.15	5.2	0.1	11.8	0.12	4.2	0.1	8.8	0.1	3.1	0.1	5.9	0.1	2.1	0.1	2.9	0.1	1	0.1	1.5	0.1	0.5	0.1	0.6	0.1	0.2	0.1
50	0.05	0.013	14.7	0.1	5.2	0.1	11.8	0.1	4.2	0.1	8.8	0.1	3.1	0.1	5.9	0.1	2.1	0.1	2.9	0.1	1	0.1	1.5	0.1	0.5	0.1	0.6	0.1	0.2	0.1

Note: values are valid at an ambient temperature of 20 °C

- Duty cycle 10-20%
- Duty cycle < 10%
- only static permissible

Performance table

for worm gear screw jacks M/J

M4-TR 40x7

n [rpm]	Stroke speed [m/min]		F=50 [kN]				F=40 [kN]				F=30 [kN]				F=20 [kN]				F=10 [kN]				F=5 [kN]				F=2.5 [kN]			
			7:1		28:1		7:1		28:1		7:1		28:1		7:1		28:1		7:1		28:1		7:1		28:1		7:1		28:1	
	H	L	Nm	kW	Nm	kW	Nm	kW	Nm	kW	Nm	kW	Nm	kW	Nm	kW	Nm	kW	Nm	kW	Nm	kW	Nm	kW	Nm	kW	Nm	kW		
1500	1.5	0.375	31.8	5	11.1	1.7	25.5	4	8.8	1.4	19.1	3	6.6	1	12.7	2	4.4	0.7	6.4	1	2.2	0.3	3.2	0.5	1.1	0.2	1.6	0.3	0.6	0.1
1000	1	0.25	31.8	3.3	11.1	1.2	25.5	2.7	8.8	0.9	19.1	2	6.6	0.7	12.7	1.3	4.4	0.5	6.4	0.7	2.2	0.2	3.2	0.3	1.1	0.1	1.6	0.2	0.6	0.1
750	0.75	0.188	31.8	2.5	11.1	0.9	25.5	2	8.8	0.7	19.1	1.5	6.6	0.5	12.7	1	4.4	0.35	6.4	0.5	2.2	0.2	3.2	0.3	1.1	0.1	1.6	0.1	0.6	0.1
600	0.6	0.15	31.8	2	11.1	0.7	25.5	1.6	8.8	0.6	19.1	1.2	6.6	0.4	12.7	0.8	4.4	0.3	6.4	0.4	2.2	0.1	3.2	0.2	1.1	0.1	1.6	0.1	0.6	0.1
500	0.5	0.125	31.8	1.7	11.1	0.6	25.5	1.3	8.8	0.5	19.1	1	6.6	0.3	12.7	0.7	4.4	0.2	6.4	0.3	2.2	0.1	3.2	0.2	1.1	0.1	1.6	0.1	0.6	0.1
300	0.3	0.075	31.8	1	11.1	0.3	25.5	0.8	8.8	0.3	19.1	0.6	6.6	0.2	12.7	0.4	4.4	0.1	6.4	0.2	2.2	0.1	3.2	0.1	1.1	0.1	1.6	0.1	0.6	0.1
100	0.1	0.025	31.8	0.3	11.1	0.1	25.5	0.3	8.8	0.1	19.1	0.2	6.6	0.1	12.7	0.1	4.4	0.1	6.4	0.1	2.2	0.1	3.2	0.1	1.1	0.1	1.6	0.1	0.6	0.1
50	0.05	0.013	31.8	0.2	11.1	0.1	25.5	0.1	8.8	0.1	19.1	0.1	6.6	0.1	12.7	0.1	4.4	0.1	6.4	0.1	2.2	0.1	3.2	0.1	1.1	0.1	1.6	0.1	0.6	0.1

M5-TR 55x9

n [rpm]	Stroke speed [m/min]		F=100 [kN]				F=80 [kN]				F=60 [kN]				F=40 [kN]				F=20 [kN]				F=10 [kN]				F=5 [kN]			
			9:1		36:1		9:1		36:1		9:1		36:1		9:1		36:1		9:1		36:1		9:1		36:1		9:1		36:1	
	H	L	Nm	kW	Nm	kW	Nm	kW	Nm	kW	Nm	kW	Nm	kW	Nm	kW	Nm	kW	Nm	kW	Nm	kW	Nm	kW	Nm	kW	Nm	kW		
1500	1.5	0.375	67.2	10.5	21.5	3.4	53.9	8.5	17.3	2.7	40.6	6.4	13.1	2.1	27.4	4.3	8.9	1.4	14.1	2.2	4.7	0.7	7.5	1.2	2.6	0.4	4.2	0.7	1.6	0.2
1000	1	0.25	67.2	7.0	21.5	2.2	53.9	5.6	17.3	1.8	40.6	4.3	13.1	1.4	27.4	2.9	8.9	0.9	14.1	1.5	4.7	0.5	7.5	0.8	2.6	0.3	4.2	0.4	1.6	0.2
750	0.75	0.188	67.2	5.3	21.5	1.7	53.9	4.2	17.3	1.4	40.6	3.2	13.1	1.0	27.4	2.1	8.9	0.7	14.1	1.1	4.7	0.4	7.5	0.6	2.6	0.2	4.2	0.3	1.6	0.1
600	0.6	0.15	67.2	4.2	21.5	1.3	53.9	3.4	17.3	1.1	40.6	2.6	13.1	0.8	27.4	1.7	8.9	0.6	14.1	0.9	4.7	0.3	7.5	0.5	2.6	0.2	4.2	0.3	1.6	0.1
500	0.5	0.125	67.2	3.5	21.5	1.1	53.9	2.8	17.3	0.9	40.6	2.1	13.1	0.7	27.4	1.4	8.9	0.5	14.1	0.7	4.7	0.2	7.5	0.4	2.6	0.1	4.2	0.2	1.6	0.1
300	0.3	0.075	67.2	2.1	21.5	0.7	53.9	1.7	17.3	0.5	40.6	1.3	13.1	0.4	27.4	0.9	8.9	0.3	14.1	0.4	4.7	0.1	7.5	0.2	2.6	0.1	4.2	0.1	1.6	0.1
100	0.1	0.025	67.2	0.7	21.5	0.2	53.9	0.6	17.3	0.2	40.6	0.4	13.1	0.1	27.4	0.3	8.9	0.1	14.1	0.1	4.7	0.1	7.5	0.1	2.6	0.1	4.2	0.1	1.6	0.1
50	0.05	0.013	67.2	0.4	21.5	0.1	53.9	0.3	17.3	0.1	40.6	0.2	13.1	0.1	27.4	0.1	8.9	0.1	14.1	0.1	4.7	0.1	7.5	0.1	2.6	0.1	4.2	0.1	1.6	0.1

J1-TR 60x9

n [rpm]	Stroke speed [m/min]		F=150 [kN]				F=100 [kN]				F=80 [kN]				F=60 [kN]				F=40 [kN]				F=20 [kN]				F=10 [kN]			
			9:1		36:1		9:1		36:1		9:1		36:1		9:1		36:1		9:1		36:1		9:1		36:1		9:1		36:1	
	H	L	Nm	kW	Nm	kW	Nm	kW	Nm	kW	Nm	kW	Nm	kW	Nm	kW	Nm	kW	Nm	kW	Nm	kW	Nm	kW	Nm	kW	Nm	kW		
1500	1.5	0.375	125.7	19.7	42.6	6.7	83.8	13.2	28.4	4.5	67	10.5	22.7	3.6	50.3	7.9	17.1	2.7	33.5	5.3	11.4	1.8	16.8	2.6	5.7	0.9	8.4	1.3	2.8	0.4
1000	1	0.25	125.7	13.2	42.6	4.5	83.8	8.8	28.4	3	67	7	22.7	2.4	50.3	5.3	17.1	1.8	33.5	3.5	11.4	1.2	16.8	1.8	5.7	0.6	8.4	0.9	2.8	0.3
750	0.75	0.188	125.7	9.9	42.6	3.3	83.8	6.6	28.4	2.2	67	5.3	22.7	1.8	50.3	3.9	17.1	1.3	33.5	2.6	11.4	0.9	16.8	1.3	5.7	0.4	8.4	0.7	2.8	0.2
600	0.6	0.15	125.7	7.9	42.6	2.7	83.8	5.3	28.4	1.8	67	4.2	22.7	1.4	50.3	3.2	17.1	1.1	33.5	2.1	11.4	0.7	16.8	1.1	5.7	0.4	8.4	0.5	2.8	0.2
500	0.5	0.125	125.7	6.6	42.6	2.2	83.8	4.4	28.4	1.5	67	3.5	22.7	1.2	50.3	2.6	17.1	0.9	33.5	1.8	11.4	0.6	16.8	0.9	5.7	0.3	8.4	0.4	2.8	0.1
300	0.3	0.075	125.7	3.9	42.6	1.3	83.8	2.6	28.4	0.9	67	2.1	22.7	0.7	50.3	1.6	17.1	0.5	33.5	1.1	11.4	0.4	16.8	0.5	5.7	0.2	8.4	0.3	2.8	0.1
100	0.1	0.025	125.7	1.3	42.6	0.4	83.8	0.9	28.4	0.3	67	0.7	22.7	0.2	50.3	0.5	17.1	0.2	33.5	0.4	11.4	0.1	16.8	0.2	5.7	0.1	8.4	0.1	2.8	0.1
50	0.05	0.013	125.7	0.7	42.6	0.2	83.8	0.4	28.4	0.1	67	0.4	22.7	0.1	50.3	0.3	17.1	0.1	33.5	0.2	11.4	0.1	16.8	0.1	5.7	0.1	8.4	0.1	2.8	0.1

J2-TR 70x10

n [rpm]	Stroke speed [m/min]		F=200 [kN]				F=150 [kN]				F=100 [kN]				F=80 [kN]				F=60 [kN]				F=40 [kN]				F=20 [kN]			
			10:1		40:1		10:1		40:1		10:1		40:1		10:1		40:1		10:1		40:1		10:1		40:1		10:1		40:1	
	H	L	Nm	kW	Nm	kW	Nm	kW	Nm	kW	Nm	kW	Nm	kW	Nm	kW	Nm	kW	Nm	kW	Nm	kW	Nm	kW	Nm	kW	Nm	kW		
1500	1.5	0.375	146.0	22.9	47.7	7.5	109.8	17.2	36.0	5.7	73.6	11.6	24.3	3.8	59.2	9.3	19.6	3.1	44.7	7.0	15.0	2.4	30.2	4.7	10.3	1.6	15.7	2.5	5.6	0.9
1000	1	0.25	146.0	15.3	47.7	5.0	109.8	11.5	36.0	3.8	73.6	7.7	24.3	2.5	59.2	6.2	19.6	2.1	44.7	4.7	15.0	1.6	30.2	3.2	10.3	1.1	15.7	1.6	5.6	0.6
750	0.75	0.188	146.0	11.5	47.7	3.7	109.8	8.6	36.0	2.8	73.6	5.8	24.3	1.9	59.2	4.6	19.6	1.5	44.7	3.5	15.0	1.2	30.2	2.4	10.3	0.8	15.7	1.2	5.6	0.4
600	0.6	0.15	146.0	9.2	47.7	3.0	109.8	6.9	36.0	2.3	73.6	4.6	24.3	1.5	59.2	3.7	19.6	1.2	44.7	2.8	15.0	0.9	30.2	1.9	10.3	0.6	15.7	1.0	5.6	0.4
500	0.5	0.125	146.0	7.6	47.7	2.5	109.8	5.7	36.0	1.9	73.6	3.9	24.3	1.3	59.2	3.1	19.6	1.0	44.7	2.3	15.0	0.8	30.2	1.6	10.3	0.5	15.7	0.8	5.6	0.3
300	0.3	0.075	146.0	4.6	47.7	1.5	109.8	3.4	36.0	1.1	73.6	2.3	24.3	0.8	59.2	1.9	19.6	0.6	44.7	1.4	15.0	0.5	30.2	0.9	10.3	0.3	15.7	0.5	5.6	0.1
100	0.1	0.025	146.0	1.5	47.7	0.5	109.8	1.1	36.0	0.4	73.6	0.8	24.3	0.3	59.2	0.6	19.6	0.2	44.7	0.5	15.0	0.1	30.2	0.3	10.3	0.1	15.7	0.2	5.6	0.1
50	0.05	0.013	146.0	0.8	47.7	0.2	109.8	0.6	36.0	0.2	73.6	0.4	24.3	0.1	59.2	0.3	19.6	0.1	44.7	0.2	15.0	0.1	30.2	0.1	10.3	0.1	15.7	0.1	5.6	0.1

Note: values are valid at an ambient temperature of 20 °C

Performance table

for worm gear screw jacks M/J

 Duty cycle 10-20%

 Duty cycle < 10%

 only static permissible

J3-Tr 80x10

n [rpm]	Stroke speed [m/min]		F=250 [kN]				F=200 [kN]				F=150 [kN]				F=100 [kN]				F=80 [kN]				F=60 [kN]				F=40 [kN]			
			10:1		40:1		10:1		40:1		10:1		40:1		10:1		40:1		10:1		40:1		10:1		40:1		10:1		40:1	
	H	L	Nm	kW	Nm	kW	Nm	kW	Nm	kW	Nm	kW	Nm	kW	Nm	kW	Nm	kW	Nm	kW	Nm	kW	Nm	kW	Nm	kW	Nm	kW		
1500	1.5	0.375	209.4	32.9	71.1	11.2	167.5	26.3	56.8	8.9	125.7	19.7	42.6	6.7	83.8	13.2	28.4	4.5	67	10.5	22.7	3.6	50.3	7.9	17.1	2.7	33.5	5.3	11.4	1.8
1000	1	0.25	209.4	21.9	71.1	7.4	167.5	17.5	56.8	6	125.7	13.2	42.6	4.5	83.8	8.8	28.4	3	67	7	22.7	2.4	50.3	5.3	17.1	1.8	33.5	3.5	11.4	1.2
750	0.75	0.188	209.4	16.4	71.1	5.6	167.5	13.2	56.8	4.5	125.7	9.9	42.6	3.3	83.8	6.6	28.4	2.2	67	5.3	22.7	1.8	50.3	3.9	17.1	1.3	33.5	2.6	11.4	0.9
600	0.6	0.15	209.4	13.2	71.1	4.5	167.5	10.5	56.8	3.6	125.7	7.9	42.6	2.7	83.8	5.3	28.4	1.8	67	4.2	22.7	1.4	50.3	3.2	17.1	1.1	33.5	2.1	11.4	0.7
500	0.5	0.125	209.4	11	71.1	3.7	167.5	8.8	56.8	3	125.7	6.6	42.6	2.2	83.8	4.4	28.4	1.5	67	3.5	22.7	1.2	50.3	2.6	17.1	0.9	33.5	1.8	11.4	0.6
300	0.3	0.075	209.4	6.6	71.1	2.2	167.5	5.3	56.8	1.8	125.7	3.9	42.6	1.3	83.8	2.6	28.4	0.9	67	2.1	22.7	0.7	50.3	1.6	17.1	0.5	33.5	1.1	11.4	0.4
100	0.1	0.025	209.4	2.2	71.1	0.7	167.5	1.8	56.8	0.6	125.7	1.3	42.6	0.4	83.8	0.9	28.4	0.3	67	0.7	22.7	0.2	50.3	0.5	17.1	0.2	33.5	0.4	11.4	0.1
50	0.05	0.013	209.4	1.1	71.1	0.4	167.5	0.9	56.8	0.3	125.7	0.7	42.6	0.2	83.8	0.4	28.4	0.1	67	0.4	22.7	0.1	50.3	0.3	17.1	0.1	33.5	0.2	11.4	0.1

J4-TR 100x10

n [rpm]	Stroke speed [m/min]		F=350 [kN]				F=300 [kN]				F=250 [kN]				F=200 [kN]				F=150 [kN]				F=100 [kN]				F=50 [kN]			
			10:1		40:1		10:1		40:1		10:1		40:1		10:1		40:1		10:1		40:1		10:1		40:1		10:1		40:1	
	H	L	Nm	kW	Nm	kW	Nm	kW	Nm	kW	Nm	kW	Nm	kW	Nm	kW	Nm	kW	Nm	kW	Nm	kW	Nm	kW	Nm	kW	Nm	kW		
1500	1.5	0.375	371.4	58.3	126.6	19.9	318.3	50	108.5	17	265.3	41.7	90.4	14.2	212.2	33.3	72.3	11.4	159.2	25	54.3	8.5	106.1	16.7	36.2	5.7	53.1	8.3	18.1	2.8
1000	1	0.25	371.4	38.9	126.6	13.3	318.3	33.3	108.5	11.4	265.3	27.8	90.4	9.5	212.2	22.2	72.3	7.6	159.2	16.7	54.3	5.7	106.1	11.1	36.2	3.8	53.1	5.6	18.1	1.9
750	0.75	0.188	371.4	29.2	126.6	9.9	318.3	25	108.5	8.5	265.3	20.8	90.4	7.1	212.2	16.7	72.3	5.7	159.2	12.5	54.3	4.3	106.1	8.3	36.2	2.8	53.1	4.2	18.1	1.4
600	0.6	0.15	371.4	23.3	126.6	8	318.3	20	108.5	6.8	265.3	16.7	90.4	5.7	212.2	13.3	72.3	4.5	159.2	10	54.3	3.4	106.1	6.7	36.2	2.3	53.1	3.3	18.1	1.1
500	0.5	0.125	371.4	19.4	126.6	6.6	318.3	16.7	108.5	5.7	265.3	13.9	90.4	4.7	212.2	11.1	72.3	3.8	159.2	8.3	54.3	2.8	106.1	5.6	36.2	1.9	53.1	2.8	18.1	0.9
300	0.3	0.075	371.4	11.7	126.6	4	318.3	10	108.5	3.4	265.3	8.3	90.4	2.8	212.2	6.7	72.3	2.3	159.2	5	54.3	1.7	106.1	3.3	36.2	1.1	53.1	1.7	18.1	0.6
100	0.1	0.025	371.4	3.9	126.6	1.3	318.3	3.3	108.5	1.1	265.3	2.8	90.4	0.9	212.2	2.2	72.3	0.8	159.2	1.7	54.3	0.6	106.1	1.1	36.2	0.4	53.1	0.6	18.1	0.2
50	0.05	0.013	371.4	1.9	126.6	0.7	318.3	1.7	108.5	0.6	265.3	1.4	90.4	0.5	212.2	1.1	72.3	0.4	159.2	0.8	54.3	0.3	106.1	0.6	36.2	0.2	53.1	0.3	18.1	0.1

J5-TR 120x14

n [rpm]	Stroke speed [m/min]		F=500 [kN]				F=400 [kN]				F=300 [kN]				F=200 [kN]				F=150 [kN]				F=100 [kN]				F=50 [kN]			
			14:1		56:1		14:1		56:1		14:1		56:1		14:1		56:1		14:1		56:1		14:1		56:1		14:1		56:1	
	H	L	Nm	kW	Nm	kW	Nm	kW	Nm	kW	Nm	kW	Nm	kW	Nm	kW	Nm	kW	Nm	kW	Nm	kW	Nm	kW	Nm	kW	Nm	kW		
1000	1	0.25	531	55.6	181	18.9	424	44.4	145	15.2	318	33.3	108	11.4	212	22.2	72	7.6	159	16.7	54	5.7	106	11.1	36	3.8	53	5.6	18	1.9
750	0.75	0.188	531	41.7	181	14.2	424	33.3	145	11.4	318	25	108	8.5	212	16.7	72	5.7	159	12.5	54	4.3	106	8.3	36	2.8	53	4.2	18	1.4
600	0.6	0.15	531	33.3	181	11.4	424	26.7	145	9.1	318	20	108	6.8	212	13.3	72	4.5	159	10	54	3.4	106	6.7	36	2.3	53	3.3	18	1.1
500	0.5	0.125	531	27.8	181	9.5	424	22.2	145	7.6	318	16.7	108	5.7	212	11.1	72	3.8	159	8.3	54	2.8	106	5.6	36	1.9	53	2.8	18	0.9
300	0.3	0.075	531	16.7	181	5.7	424	13.3	145	4.5	318	10	108	3.4	212	6.7	72	2.3	159	5	54	1.7	106	3.3	36	1.1	53	1.7	18	0.6
100	0.1	0.025	531	5.6	181	1.9	424	4.4	145	1.5	318	3.3	108	1.1	212	2.2	72	0.8	159	1.7	54	0.6	106	1.1	36	0.4	53	0.6	18	0.2
50	0.05	0.013	531	2.8	181	0.9	424	2.2	145	0.8	318	1.7	108	0.6	212	1.1	72	0.4	159	0.8	54	0.3	106	0.6	36	0.2	53	0.3	18	0.1

Note: values are valid at an ambient temperature of 20 °C

Ordering code

Worm gear screw jacks

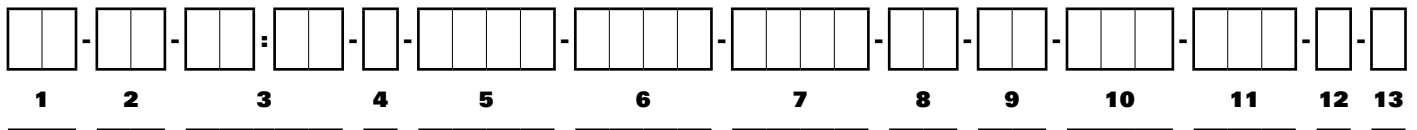

No.	Designation	Code	Description
1	Size	M1, M2, ...	
		J1, J2, ...	
2	Design	N	Lifting spindle
		VP	Lifting spindle, protected against twisting by feather key
		VK	Lifting spindle, protected against twisting by square tube
		R	Rotating spindle
3	Transmission ratio	4:1 / 16:1	For M0, M1, M2
		6:1 / 24:1	For M3
		7:1 / 28:1	For M4
		9:1 / 36:1	For M5 and J1
		10:1 / 40:1	For J2, J3, J4
		14:1 / 56:1	For J5
4	Type of spindle	T	Trapezoidal screw drive
		K	Ball screw drive
5	Spindle dimension		e.g. 2005 = diameter 20 mm, pitch 5 mm
6	Stroke in [mm]		Specification of the stroke length
7	Attached part for version N/VK/VP		Spindle extension VL, Usable stroke length NL, e.g. due to block dimension bellows, mounting situation. See product drawings at page 57-60.
	Usable stroke length NL for version R		
8	Spindle end	M	Metric threaded stem
		A	End with chamfer
		S	Custom (according to specification, description or drawing)
		Z	Centric stem (standard for version R)
9	Attached part for version N/VK/VP	0	None
		BP	With fastening plate mounted
		GA	With spherical bearing mounted
		GK	With fork end mounted
		HG	With high-performance fork end mounted
	Nut type for version R	F-D	Flanged nut according to DIN 69051 (flange direction to housing)
		F-N	Flanged nut according to NEFF-Norm (flange direction to housing)
		D-F	Flanged nut according to DIN 69051 (flange direction to screw end)
		N-F	Flanged nut according to NEFF-Norm (flange direction to screw end)
10	Spindle cover	0	None
		FB	With bellows
		SF	With spiral spring cover
11	Anti-unscrewing device	0	None
		AS	With (installed as standard in KGT)
12	Shaft end	0	On both sides A+B (Standard)
		A	Shaft end on Side A
		B	Shaft end on side B
13	Special requirements	0	None
		1	According to specification, description or drawing

High-Performance Screw Jacks MH/JH

Technical Data

High-Performance Screw Jacks Series MH/JH

The High Performance Screw Jacks are convincing with optimized worm gearing for higher efficiency and longer duty cycles. The separate lubrication system of the screw and the gear box allows an input-speed up to 3000 1/min. Enhanced drive torque and maximum lifetime are given by hardened and grinded worm gears.

High Performance Screw Jacks with trapezoidal screw

		MH 1	MH 2	MH 3	MH 4	MH 5	JH 3
Maximum lifting force [kN] ¹⁾		15	17	46	88	106	350
Diameter and pitch [mm]		18 x 4	20 x 4	30 x 6	40 x 7	55 x 9	80 x 10
Stroke per revolution of the drive shaft [mm]	ratio H ²⁾	1	1	1	1	1	1
	ratio L ²⁾	0,25	0,25	0,25	0,25	0,25	0,25
Transmission ratio	ratio H ²⁾	4:1	4:1	6:1	7:1	9:1	10:1
	ratio L ²⁾	16:1	16:1	24:1	28:1	36:1	40:1
Overall efficiency [%] ³⁾	ratio H ²⁾	37	34	34	32	27	21
	ratio L ²⁾	32	30	29	28	24	16
Weight [kg] (without stroke)		1,2	2,1	6	17	32	57
Weight [kg per 100 mm stroke]		0,26	0,42	1,14	1,67	3,04	6,13
Idling torque [Nm]	H	0,04	0,11	0,15	0,35	0,84	1,32
	L	0,03	0,10	0,12	0,25	0,51	0,97
Housing material		G – AL to M3			GGG – 40		
Gear efficiency ⁴⁾	H	0,83-0,86	0,82-0,87	0,81-0,86	0,84-0,87	0,74-0,8	0,63-0,78
	L	0,7-0,76	0,67-0,76	0,64-0,75	0,65-0,77	0,61-0,69	0,46-0,55
Maximum drive torque (Nm)	H	9	23,3	38,4	78,6	162,1	268,4
	L	9	23,3	38,4	78,6	162,1	182,9

High Performance Screw Jacks with ball screw

		MH 1	MH 2	MH 3	MH 4	MH 5	JH 3
Maximum lifting force [kN] ¹⁾		9	10	12,5	24	69	82
Diameter and pitch [mm]		1605	2005	2505	4005	5010	8010
Stroke per revolution of the drive shaft [mm]	ratio H ²⁾	1,25	1,25	0,83	0,71	1,1	1
	ratio L ²⁾	0,31	0,31	0,21	0,18	0,28	0,25
Transmission ratio	ratio H ²⁾	4:1	4:1	6:1	7:1	9:1	10:1
	ratio L ²⁾	16:1	16:1	24:1	28:1	36:1	40:1
Overall efficiency [%] ³⁾	ratio H ²⁾	83	82	80	78	70	60
	ratio L ²⁾	78	72	67	66	60	45
Weight [kg] (without stroke)		1,3	2,3	7	19	35	63
Weight [kg per 100 mm stroke]		0,26	0,42	1,14	1,67	3,04	6,13
Idling torque [Nm]	H	0,04	0,11	0,15	0,35	0,84	1,32
	L	0,03	0,10	0,12	0,25	0,51	0,97
Housing material		G – AL to M3			GGG – 40		
Gear efficiency ⁴⁾	H	0,83-0,86	0,82-0,87	0,81-0,86	0,84-0,87	0,74-0,8	0,63-0,78
	L	0,7-0,76	0,67-0,76	0,64-0,75	0,65-0,77	0,61-0,69	0,46-0,55
Maximum drive torque (Nm)	H	9	23,3	38,4	78,6	162,1	268,4
	L	9	23,3	38,4	78,6	162,1	182,9

¹⁾ Dependent on stroke speed, duty cycle, etc.

²⁾ H = High travel speed,

L = Low travel speed.

³⁾ The specified overall values are average values

⁴⁾ Calculate with the low value if you have lower speeds, with the high value if you have higher input speeds.

High-Performance Screw Jacks MH/JH

Dimensions - Design N

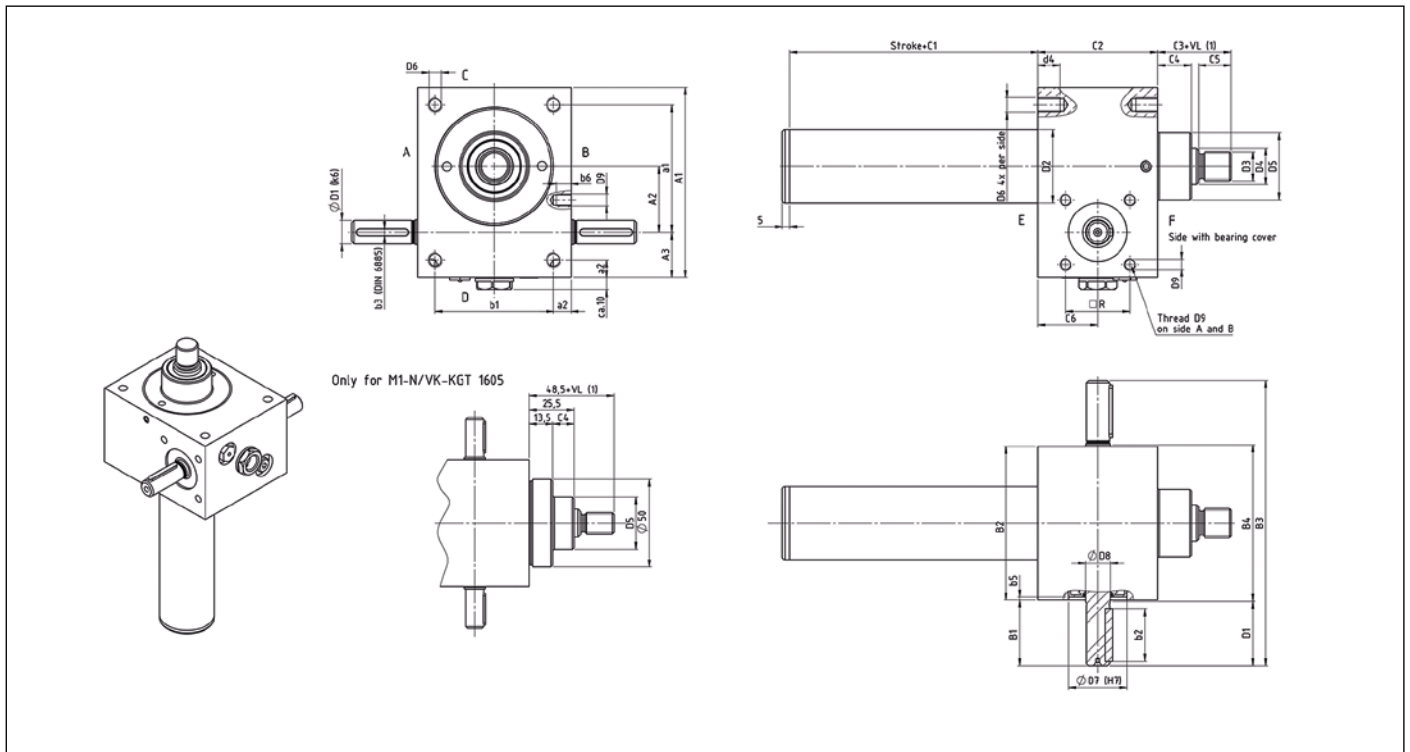

Size	Dimensions [mm]																
	A ₁	A ₂	A ₃	a ₁	a ₂	B ₁	B ₂	B ₃	B ₄	b ₁	b ₂	b ₃	b ₅	C ₁ TR ⁽²⁾	C ₁ KGT/AS ⁽³⁾	C ₂	C ₃
MH 1	80	25	24	60	10	24	72	120	77	52	18	3	1,5	20	50	62	35
MH 2	100	32	28	78	11	27,5	85	140	90	63	20	5	1,5	30	60	75	45
MH 3	130	45	31	106	12	45	105	195	110	81	36	5	2	35	70	82	50
MH 4	180	63	39	150	15	47,5	145	240	150	115	36	6	2	40	90	117	65
MH 5	200	71	46	166	17	67,5	165	300	170	131	56	8	2,5	55	100	160	95
JH 3	240	80	60	190	25	67,5	220	355	225	170	56	8	8	60	110	165	110

Size	Dimensions [mm]														
	C ₄	C ₅	C ₆	D _{1k6}	D ₂	D ₃	d ₄	D ₄ Tr	D ₄ KGT	D ₅	D ₆	D ₇ ^{H7}	D ₈	D ₉ x b ₆	TK □ R
MH 1	12	19	31	10 x 21,5	32	M12	13	Tr18 x 4	1605	30	M8	32	12	M5 x 6	32
MH 2	18	20	37,5	14 x 25	40	M14	15	Tr20 x 4	2005	38,7	M8	35	15	M6 x 10	35
MH 3	23	22	41	16 x 42,5	50	M20	15	Tr30 x 6	2505	46	M10	40	17	M8 x 10	44
MH 4	32	29	58,5	20 x 45	65	M30	16	Tr40 x 7	4005/4010	60	M12	52	25	M10 x 14	55
MH 5	40	48	80	25 x 65	90	M36	30	Tr55 x 9	5010	85	M20	62	28	M12 x 16	70
JH 3	40	58	82,5	30 x 65	125	M64 x 3	45	Tr80 x 10	8010	120	M30	80	32	M12 x 18	(80)

Note: subject to technical changes

- (1) Screw extension
- (2) For trapezoidal screw
- (3) For ballscrews or anti-unscrewing device

High-Performance Screw Jacks MH/JH

Dimensions - Design VK

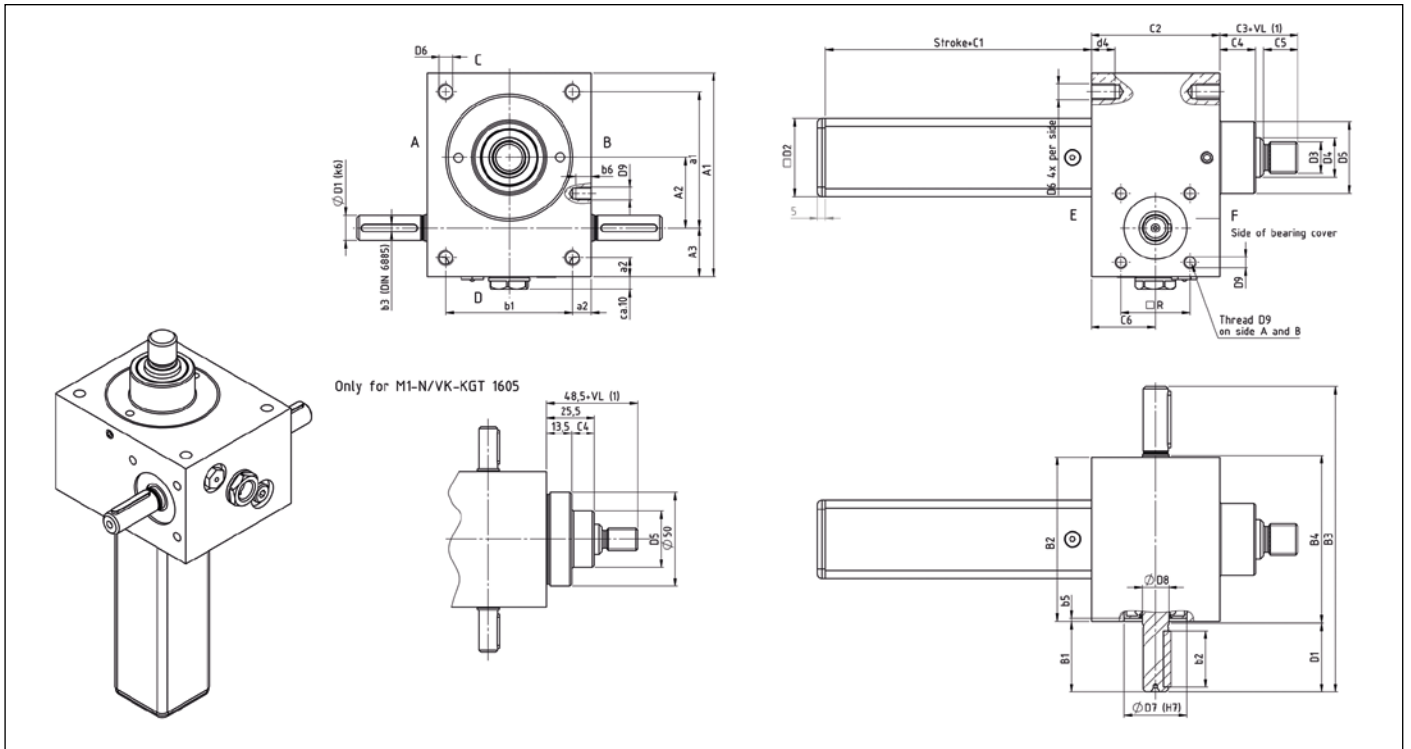

Size	Dimensions [mm]															
	A ₁	A ₂	A ₃	a ₁	a ₂	B ₁	B ₂	B ₃	B ₄	b ₁	b ₂	b ₃	b ₅	C ₁	C ₂	C ₃
MH 1	80	25	24	60	10	24	72	120	77	52	18	3	1,5	50	62	35
MH 2	100	32	28	78	11	27,5	85	140	90	63	20	5	1,5	60	75	45
MH 3	130	45	31	106	12	45	105	195	110	81	36	5	2	70	82	50
MH 4	180	63	39	150	15	47,5	145	240	150	115	36	6	2	90	117	65
MH 5	200	71	46	166	17	67,5	165	300	170	131	56	8	2,5	100	160	95
JH 3	240	80	60	190	25	67,5	220	355	225	170	56	8	8	110	165	110

Size	Dimensions [mm]														
	C ₄	C ₅	C ₆	D _{1K6}	D ₃	d ₄	D _{4Tr}	D _{4KGT}	D ₅	D ₆	D ₇ ^{H7}	D ₈	D ₉ x b ₆	TK □ R	V-KGT
MH 1	12	19	31	10 x 21,5	M12	13	Tr18 x 4	1605	30	M8	32	12	M5 x 6	32	35 x 35
MH 2	18	20	37,5	14 x 25	M14	15	Tr20 x 4	2005	38,7	M8	35	15	M6 x 10	35	40 x 40
MH 3	23	22	41	16 x 42,5	M20	15	Tr30 x 6	2505	46	M10	40	17	M8 x 10	44	50 x 50
MH 4	32	29	58,5	20 x 45	M30	16	Tr40 x 7	4005/4010	60	M12	52	25	M10 x 14	55	70 x 70
MH 5	40	48	80	25 x 65	M36	30	Tr55 x 9	5010	85	M20	62	28	M12 x 16	70	90 x 90
JH 3	40	58	82,5	30 x 65	M64 x 3	45	Tr80 x 10	8010	120	M30	80	32	M12 x 18	(80)	125 x 125

Note: subject to technical changes

(1) Screw extension

High-Performance Screw Jacks MH/JH

Dimensions - Design R

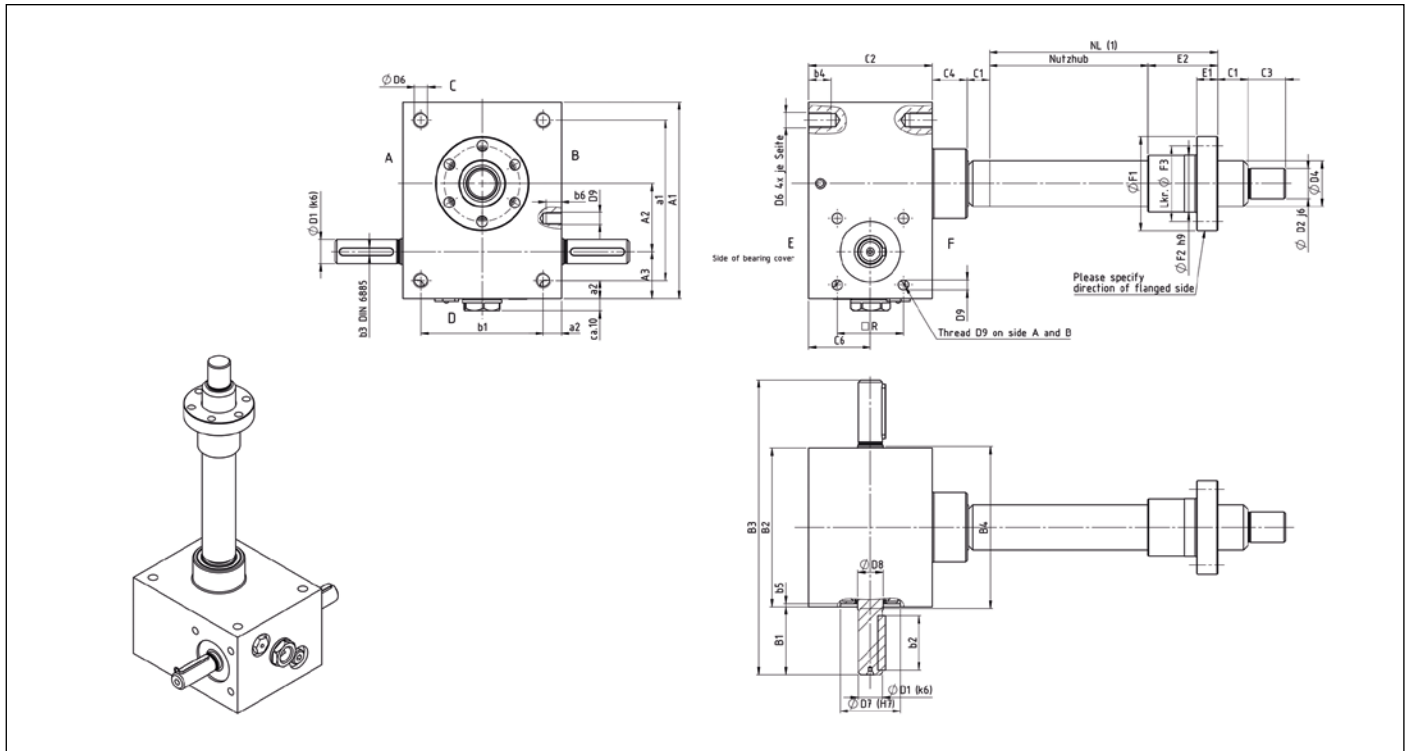

Size	Dimensions [mm]																		
	A ₁	A ₂	A ₃	a ₁	a ₂	B ₁	B ₂	B ₃	B ₄	b ₁	b ₂	b ₃	b ₄	b ₅	C ₁	C ₂	C ₃	C ₄	C ₆
MH 1	80	25	24	60	10	24	72	120	77	52	18	3	13	1,5	12	62	15	12	31
MH 2	100	32	28	78	11	27,5	85	140	90	63	20	5	15	1,5	15	75	20	18	37,5
MH 3	130	45	31	106	12	45	105	195	110	81	36	5	15	2	20	82	25	23	41
MH 4	180	63	39	150	15	47,5	145	240	150	115	36	6	16	2	25	117	30	32	58,5
MH 5	200	71	46	166	17	67,5	165	300	170	131	56	8	30	2,5	25	160	45	40	80
JH 3	240	80	60	190	25	67,5	220	355	225	170	56	8	45	8	25	165	75	40	82,5

Size	Dimensions [mm]																
	D _{1k6}	D _{2j6}	D _{4TR}	D _{4KGT}	D ₅	D ₆	D _{7^{H7}}	D ₈	D ₉ x b ₆	□ R	E ₁	E ₂	F ₁	F ₂	F ₃	F ₄	
MH 1	10 x 21,5	12	Tr18 x 4	1605	30	M8	32	12	(M5 x 6)*	32	12/12	44/44	48/48	28/28	38/38	6/6	
MH 2	14 x 25	15	Tr20 x 4	2005	36,1	M8	32	15	M6 x 10	35	12/12	44/44	55/55	32/32	45/45	7/7	
MH 3	16 x 42,5	20	Tr30 x 6	2505	46	M10	40	17	M8 x 10	44	14/14	46/46	62/62	38/38	50/50	7/7	
MH 4	20 x 45	25	Tr40 x 7	4005/4010	60	M12	52	25	M10 x 14	55	16/16	73/59	95/80	63/53	78/68	9/7	
MH 5	25 x 65	40	Tr55 x 9	5010	85	M20	62	28	M12 x 16	70	18/18	97/97	110/110	72/72	90/90	11/11	
JH 3	30 x 65	60	Tr80 x 10	8010	120	M30	80	32	M12 x 18	(80)	30/22	110/101	190/145	105/105	150/125	17/14	

(1) NL: usable stroke length

Note: subject to technical changes

High-Performance Screw Jacks MH/JH with limit switches

Technical Data and Dimensions

Limit switch with roller plunger:

Actuating cam 30° according to DIN 69639

- Minimum actuation stroke: 2.6 mm +/- 0.5mm
- Differential stroke: 0.85 mm +/- 0.25mm
- Minimum switch-on force: 1 N
- Start-up speed: 0.001 to 0.1 m/s
- Connection: 5-core (brown/blue: normally open; black/black: normally closed; green/yellow: earth conductor)
- Switching capacity: NFC 63146

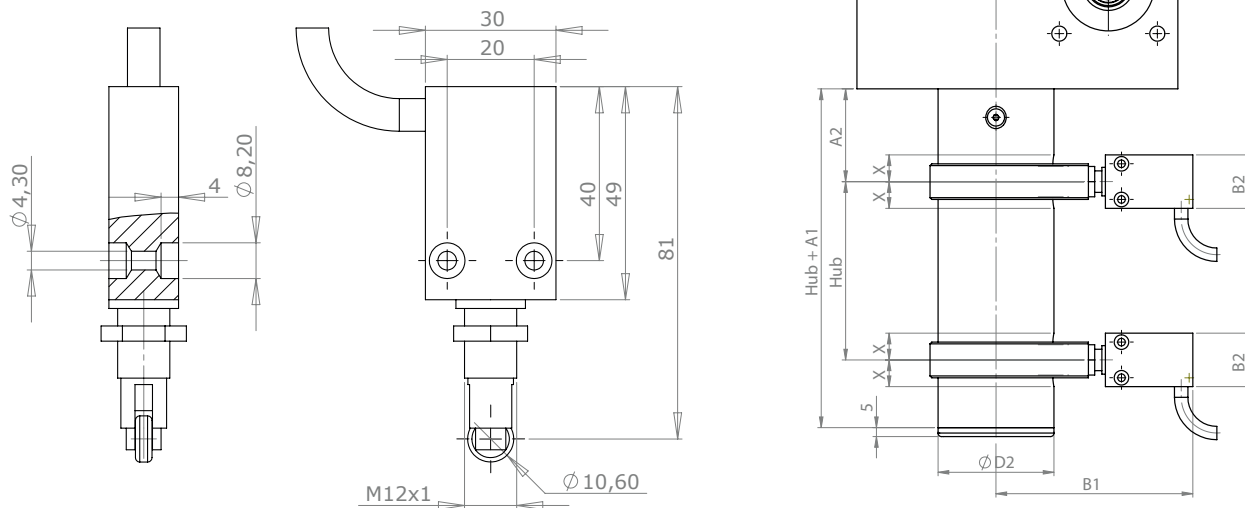

Size	Dimensions [mm]						
	A ₁	A ₂	B ₁	B ₂	M	X	Ø D2
MH 1	65	27	96	30	M12x1	±10	32
MH 2	65	32	100	30	M12x1	±10	40
MH 3	75	41	105	30	M12x1	±10	50
MH 4	90	52	113	30	M12x1	±10	65
MH 5	100	60	125	30	M12x1	±10	90
JH 3	on enquiry						

Performance Data

High-Performance Screw Jacks MH/JH

NEFF Performance tables

The NEFF Performance tables illustrate a simple overview to check the drive power, the drive torque and the holding torque for different speeds and lifting forces. Please calculate the max. surface pressure and the max. travel speed separately. These values are not included in the performance tables.

See chapter: Calculation Trapezoidal drives

To calculate Screw jacks with other screw pitches use the formula below¹⁾

$$\frac{\text{required screw pitch } P \text{ (mm)}}{\text{standard screw pitch } P \text{ (mm)}} \times \text{Value of NEFF Performance tables}$$

¹⁾ Circa Values! No consideration of efficiency

For exact calculation, please use the design and calculation criteria in the chapter: Calculation Screw Jacks

Legend for NEFF Performance tables

- F** Lifting force
- H** Transmission ratio for low travel speed
- L** Transmission ratio for high travel speed
- Nm** Drive torque for lifting torque
- HNm** Holding torque for static lifting force
- kW** Driving power as a function of speed

NEFF Operating time chart

NEFF Operating time charts calculate for 20° C ambient temperature and the standard screw sizes.

Please contact us if you need operating time charts for other temperature or screw sizes.

To calculate the operating time in %/h for other speeds, use the speed factor $f_{n_{\text{neff}}}$ in the tables of the chart.

Different efficiency from different speeds ignore in the calculation.

Performance Data

High-Performance Screw Jacks MH/JH

Duty cycle chart for 1500 1/min and 20° C temperature.

To calculate the Operating time ED_n/h for other speeds, multiply the Operating time in [%] with the speed-factor fn_{neff} :

$$ED_n/h \text{ in } [\%] = ED_d/h \times fn_{neff}$$

If different speeds determine the average of speed:

$$n_m = n_1 \times q_1 + n_2 \times q_2 + \dots + n_i \times q_i / 100$$

n_1, n_2, \dots = Speed in [1/min] during the clearance

q_1, q_2, \dots = Dues of load duration in [%]

n_m = Average speed in [1/min]

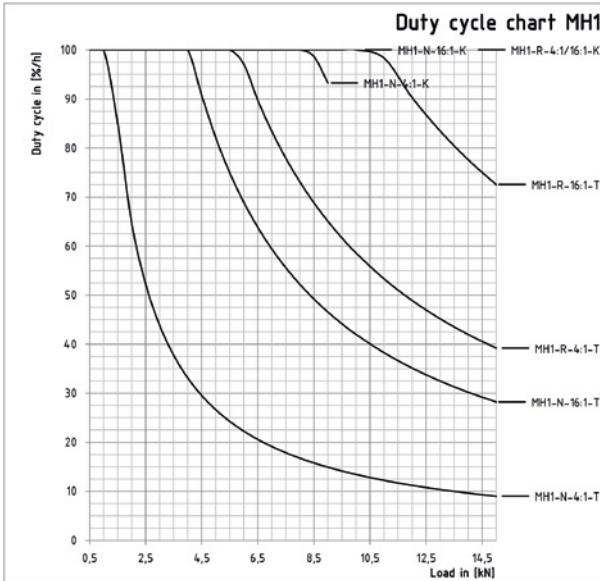

speed	speed factor fn_{neff}
3000	0,5
2500	0,6
2000	0,75
1000	1,5
750	2
500	3
250	6

MH1-T-18x4

n [1/ min]	Stroke speed [m/min]		F=15 [kN]		F=10 [kN]		F=8 [kN]		F=5 [kN]		F=2 [kN]		F=1 [kN]													
			4:1		16:1		4:1		16:1		4:1		16:1		4:1		16:1									
	H	L	Nm	kW	Nm	kW	Nm	kW	Nm	kW	Nm	kW	Nm	kW	Nm	kW	Nm	kW	Nm	kW	Nm	kW				
3000	3,00	0,75	6,49	2,04	1,90	0,60	4,34	1,36	1,27	0,40	3,48	1,09	1,02	0,32	2,19	0,69	0,65	0,20	0,90	0,28	0,28	0,09	0,47	0,09	0,15	0,05
2750	2,75	0,69	6,49	1,87	1,90	0,55	4,34	1,25	1,27	0,37	3,48	1,00	1,02	0,30	2,19	0,63	0,65	0,19	0,90	0,26	0,28	0,08	0,47	0,09	0,15	0,04
2500	2,50	0,63	6,49	1,70	1,90	0,50	4,34	1,14	1,27	0,33	3,48	0,91	1,02	0,27	2,19	0,57	0,65	0,17	0,90	0,24	0,28	0,07	0,47	0,09	0,15	0,04
2250	2,25	0,56	6,49	1,53	1,90	0,45	4,34	1,02	1,27	0,30	3,48	0,82	1,02	0,24	2,19	0,52	0,65	0,15	0,90	0,21	0,28	0,07	0,47	0,09	0,15	0,04
2000	2,00	0,50	6,49	1,36	1,90	0,40	4,34	0,91	1,27	0,27	3,48	0,73	1,02	0,21	2,19	0,46	0,65	0,14	0,90	0,19	0,28	0,06	0,47	0,09	0,15	0,03
1500	1,50	0,38	6,49	1,02	1,90	0,30	4,34	0,68	1,27	0,20	3,48	0,55	1,02	0,16	2,19	0,34	0,65	0,10	0,90	0,14	0,28	0,04	0,47	0,09	0,15	0,02
1000	1,00	0,25	6,49	0,68	1,90	0,20	4,34	0,45	1,27	0,13	3,48	0,36	1,02	0,11	2,19	0,23	0,65	0,07	0,90	0,09	0,28	0,03	0,47	0,09	0,15	0,02
500	0,50	0,13	6,49	0,34	1,90	0,10	4,34	0,23	1,27	0,07	3,48	0,18	1,02	0,05	2,19	0,11	0,65	0,03	0,90	0,05	0,28	0,01	0,47	0,09	0,15	0,01

MH1-K-1605

n [1/min]	Stroke speed [m/min]		F=9 [kN]			F=8 [kN]			F=6 [kN]											
			4:1		16:1	4:1		16:1	4:1		16:1									
	H	L	Nm	HNm	kW	Nm	HNm	kW	Nm	HNm	kW	Nm	HNm	kW	Nm	HNm	kW			
3000	3,75	0,94	2,20	1,15	0,69	0,64	0,23	0,20	1,96	1,02	0,61	0,57	0,20	0,18	1,48	0,36	0,46	0,44	0,14	0,14
2750	3,44	0,86	2,20	1,15	0,63	0,64	0,23	0,18	1,96	1,02	0,56	0,57	0,20	0,16	1,48	0,36	0,43	0,44	0,14	0,13
2500	3,13	0,78	2,20	1,15	0,58	0,64	0,23	0,17	1,96	1,02	0,51	0,57	0,20	0,15	1,48	0,36	0,39	0,44	0,14	0,11
2250	2,81	0,70	2,20	1,15	0,52	0,65	0,23	0,15	1,96	1,02	0,46	0,58	0,20	0,14	1,48	0,36	0,35	0,44	0,14	0,10
2000	2,50	0,63	2,22	1,13	0,47	0,65	0,23	0,14	1,98	1,00	0,41	0,58	0,20	0,12	1,50	0,35	0,31	0,44	0,14	0,09
1500	1,88	0,47	2,22	1,13	0,35	0,66	0,22	0,10	1,96	1,02	0,31	0,58	0,20	0,09	1,48	0,36	0,23	0,44	0,14	0,07
1000	1,25	0,31	2,22	1,11	0,23	0,69	0,21	0,07	1,98	0,98	0,21	0,58	0,20	0,06	1,53	0,72	0,16	0,47	0,13	0,05
500	0,63	0,16	2,22	1,11	0,12	0,69	0,21	0,04	1,98	0,98	0,10	0,58	0,20	0,03	1,53	0,72	0,08	0,47	0,13	0,02

MH1-K-1605

n [1/min]	Stroke speed [m/min]		F=4 [kN]			F=2 [kN]			F=1 [kN]											
			4:1		16:1	4:1		16:1	4:1		16:1									
	H	L	Nm	HNm	kW	Nm	HNm	kW	Nm	HNm	kW	Nm	HNm	kW						
3000	3,75	0,94	1,00	0,49	0,31	0,30	0,09	0,09	0,52	0,22	0,16	0,17	0,03	0,05	0,28	0,28	0,09	0,10	-	0,03
2750	3,44	0,86	1,00	0,49	0,29	0,30	0,09	0,09	0,52	0,22	0,15	0,17	0,03	0,05	0,28	0,09	0,08	0,10	-	0,03
2500	3,13	0,78	1,00	0,49	0,26	0,30	0,09	0,08	0,52	0,22	0,14	0,17	0,03	0,04	0,28	0,09	0,07	0,10	-	0,03
2250	2,81	0,70	1,00	0,49	0,24	0,30	0,09	0,07	0,52	0,22	0,12	0,17	0,03	0,04	0,28	0,09	0,07	0,10	-	0,02
2000	2,50	0,63	1,01	0,48	0,21	0,30	0,08	0,06	0,53	0,22	0,11	0,17	0,03	0,03	0,28	0,09	0,06	0,10	-	0,02
1500	1,88	0,47	1,00	0,49	0,16	0,30	0,09	0,05	0,52	0,22	0,08	0,17	0,03	0,03	0,28	0,09	0,04	0,10	-	0,02
1000	1,25	0,31	1,01	0,47	0,11	0,32	0,08	0,03	0,54	0,21	0,06	0,18	0,02	0,02	0,29	0,09	0,03	0,10	-	0,01
500	0,63	0,16	1,01	0,47	0,05	0,32	0,08	0,02	0,54	0,21	0,03	0,18	0,02	0,01	0,29	0,09	0,02	0,10	-	0,01

Performance Data

High-Performance Screw Jacks MH/JH

Duty cycle chart for 1500 1/min and 20° C temperature.

To calculate the Operating time ED_n/h for other speeds, multiply the Operating time in [%] with the speed-factor f_{n_{neff}}:

$$ED_n/h \text{ in } [\%] = ED_d/h \times f_{n_{neff}}$$

If different speeds determine the average of speed:

$$n_m = n_1 \times q_1 + n_2 \times q_2 + \dots + n_i \times q_i / 100$$

n₁, n₂, ... = Speed in [1/min] during the clearance

q₁, q₂, ... = Dues of load duration in [%]

n_m = Average speed in [1/min]

speed	speed factor f _{n_{neff}}
3000	0,5
2500	0,6
2000	0,75
1000	1,5
750	2
500	3
250	6

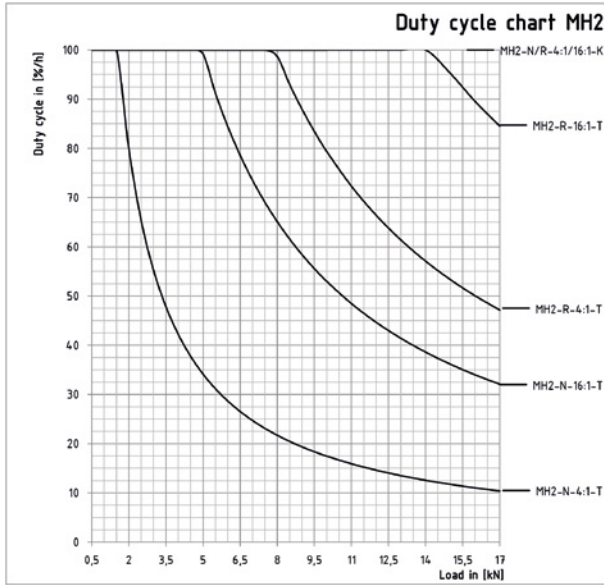

MH2-T-20x4																										
n [1/min]	Stroke speed [m/min]		F=17 [kN]				F=13 [kN]				F=8 [kN]				F=5 [kN]				F=2 [kN]				F=1 [kN]			
			4:1		16:1		4:1		16:1		4:1		16:1		4:1		16:1		4:1		16:1		4:1		16:1	
	H	L	Nm	kW	Nm	kW	Nm	kW	Nm	kW	Nm	kW	Nm	kW	Nm	kW	Nm	kW	Nm	kW	Nm	kW	Nm	kW	Nm	kW
3000	3,00	0,75	8,07	2,53	2,35	0,74	6,20	1,95	1,82	0,57	3,85	1,21	1,16	0,36	2,45	0,77	0,76	0,24	1,05	0,33	0,37	0,11	0,58	0,18	0,23	0,07
2750	2,75	0,69	8,07	2,32	2,35	0,68	6,20	1,78	1,82	0,53	3,85	1,11	1,16	0,33	2,45	0,71	0,76	0,22	1,05	0,30	0,37	0,11	0,58	0,17	0,23	0,07
2500	2,50	0,63	8,07	2,11	2,35	0,62	6,20	1,62	1,82	0,48	3,85	1,01	1,16	0,30	2,45	0,64	0,76	0,20	1,05	0,27	0,37	0,10	0,58	0,15	0,23	0,06
2250	2,25	0,56	8,07	1,90	2,35	0,55	6,20	1,46	1,82	0,43	3,85	0,91	1,16	0,27	2,45	0,58	0,76	0,18	1,05	0,25	0,37	0,09	0,58	0,14	0,23	0,05
2000	2,00	0,50	8,07	1,69	2,35	0,49	6,20	1,30	1,82	0,38	3,85	0,81	1,16	0,24	2,45	0,51	0,76	0,16	1,05	0,22	0,37	0,08	0,58	0,12	0,23	0,05
1500	1,50	0,38	8,07	1,27	2,35	0,37	6,20	0,97	1,82	0,29	3,85	0,61	1,16	0,18	2,45	0,38	0,76	0,12	1,05	0,16	0,37	0,06	0,58	0,09	0,23	0,04
1000	1,00	0,25	8,07	0,84	2,35	0,25	6,20	0,65	1,82	0,19	3,85	0,40	1,16	0,12	2,45	0,26	0,76	0,08	1,05	0,11	0,37	0,04	0,58	0,06	0,23	0,02
500	0,50	0,13	8,07	0,42	2,35	0,12	6,20	0,32	1,82	0,10	3,85	0,20	1,16	0,06	2,45	0,13	0,76	0,04	1,05	0,05	0,37	0,02	0,58	0,03	0,23	0,01

MH2-K-2005																				
n [1/min]	Stroke speed [m/min]		F=10 [kN]						F=8 [kN]						F=6 [kN]					
			4:1			16:1			4:1			16:1			4:1			16:1		
	H	L	Nm	HNm	kW	Nm	HNm	kW	Nm	HNm	kW	Nm	HNm	kW	Nm	HNm	kW	Nm	HNm	kW
3000	3,75	0,94	2,54	1,20	0,80	0,79	0,18	0,25	2,05	0,93	0,64	0,66	0,12	0,21	1,57	0,67	0,49	0,51	0,07	0,16
2750	3,44	0,86	2,54	1,20	0,73	0,79	0,18	0,23	2,05	0,93	0,59	0,66	0,12	0,19	1,57	0,67	0,45	0,51	0,07	0,15
2500	3,13	0,78	2,54	1,20	0,66	0,79	0,18	0,21	2,05	0,93	0,54	0,66	0,12	0,17	1,57	0,67	0,41	0,51	0,07	0,13
2250	2,81	0,70	2,54	1,20	0,60	0,79	0,18	0,19	2,05	0,93	0,48	0,66	0,12	0,15	1,57	0,67	0,37	0,51	0,07	0,12
2000	2,50	0,63	2,54	1,20	0,53	0,79	0,18	0,16	2,05	0,93	0,43	0,66	0,12	0,14	1,57	0,67	0,33	0,51	0,07	0,11
1500	1,88	0,47	2,54	1,20	0,40	0,79	0,18	0,12	2,05	0,93	0,32	0,66	0,12	0,10	1,57	0,67	0,25	0,51	0,07	0,08
1000	1,25	0,31	2,54	1,20	0,27	0,79	0,18	0,08	2,05	0,93	0,21	0,66	0,12	0,07	1,57	0,67	0,16	0,51	0,07	0,05
500	0,63	0,16	2,54	1,20	0,13	0,79	0,18	0,04	2,05	0,93	0,11	0,66	0,12	0,03	1,57	0,67	0,08	0,51	0,07	0,03

MH2-K-2005																				
n [1/min]	Stroke speed [m/min]		F=4 [kN]						F=2 [kN]						F=1 [kN]					
			4:1			16:1			4:1			16:1			4:1			16:1		
	H	L	Nm	HNm	kW	Nm	HNm	kW	Nm	HNm	kW	Nm	HNm	kW	Nm	HNm	kW	Nm	HNm	kW
3000	3,75	0,94	1,08	0,35	0,34	0,38	0,01	0,12	0,60	0,15	0,19	0,24	-	0,08	0,35	0,02	0,11	0,17	-	0,05
2750	3,44	0,86	1,08	0,35	0,31	0,38	0,01	0,11	0,60	0,15	0,17	0,24	-	0,07	0,35	0,02	0,10	0,17	-	0,05
2500	3,13	0,78	1,08	0,35	0,28	0,38	0,01	0,10	0,60	0,15	0,16	0,24	-	0,06	0,35	0,02	0,09	0,17	-	0,04
2250	2,81	0,70	1,08	0,35	0,25	0,38	0,01	0,09	0,60	0,15	0,14	0,24	-	0,06	0,35	0,02	0,08	0,17	-	0,04
2000	2,50	0,63	1,08	0,35	0,23	0,38	0,01	0,08	0,60	0,15	0,12	0,24	-	0,05	0,35	0,02	0,07	0,17	-	0,04
1500	1,88	0,47	1,08	0,35	0,17	0,38	0,01	0,06	0,60	0,15	0,09	0,24	-	0,04	0,35	0,02	0,06	0,17	-	0,03
1000	1,25	0,31	1,08	0,35	0,11	0,38	0,01	0,04	0,60	0,15	0,06	0,24	-	0,03	0,35	0,02	0,04	0,17	-	0,02
500	0,63	0,16	1,08	0,35	0,06	0,38	0,01	0,02	0,60	0,15	0,03	0,24	-	0,01	0,35	0,02	0,02	0,17	-	0,01

Performance Data

High-Performance Screw Jacks MH/JH

Duty cycle chart for 1500 1/min and 20° C temperature.

To calculate the Operating time ED_n/h for other speeds, multiply the Operating time in [%] with the speed-factor fn_{neff} :

$$ED_n/h \text{ in } [\%] = ED_d/h \times fn_{neff}$$

If different speeds determine the average of speed:

$$n_m = n_1 \times q_1 + n_2 \times q_2 + \dots + n_i \times q_i / 100$$

n_1, n_2, \dots = Speed in [1/min] during the clearance

q_1, q_2, \dots = Dues of load duration in [%]

n_m = Average speed in [1/min]

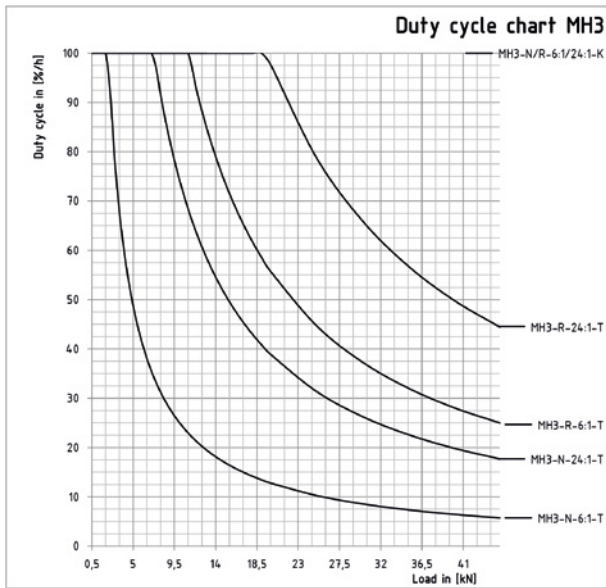

speed	speed factor fn_{neff}
3000	0,5
2500	0,6
2000	0,75
1000	1,5
750	2
500	3
250	6

MH3-T-30x6

n [1/ min]	Stroke speed [m/min]		F=46 [kN]				F=35 [kN]				F=20 [kN]				F=10 [kN]				F=5 [kN]				F=1 [kN]			
			6:1		24:1		6:1		24:1		6:1		24:1		6:1		24:1		6:1		24:1		6:1		24:1	
	H	L	Nm	kW	Nm	kW	Nm	kW	Nm	kW	Nm	kW	Nm	kW	Nm	kW	Nm	kW	Nm	kW	Nm	kW	Nm	kW	Nm	kW
3000	3,00	0,75	21,64	6,80	6,41	2,01	16,49	5,18	4,90	1,54	9,47	2,98	2,84	0,89	4,79	1,51	1,47	0,46	2,45	0,77	0,79	0,25	0,58	0,18	0,24	0,07
2750	2,75	0,69	21,64	6,23	6,41	1,85	16,49	4,75	4,90	1,41	9,47	2,73	2,84	0,82	4,79	1,38	1,47	0,42	2,45	0,71	0,79	0,23	0,58	0,17	0,24	0,07
2500	2,50	0,63	21,64	5,67	6,41	1,68	16,49	4,32	4,90	1,28	9,47	2,48	2,84	0,74	4,79	1,25	1,47	0,39	2,45	0,64	0,79	0,21	0,58	0,15	0,24	0,06
2250	2,25	0,56	21,64	5,10	6,41	1,51	16,49	3,89	4,90	1,15	9,47	2,23	2,84	0,67	4,79	1,13	1,47	0,35	2,45	0,58	0,79	0,19	0,58	0,14	0,24	0,06
2000	2,00	0,50	21,64	4,53	6,41	1,34	16,49	3,45	4,90	1,03	9,47	1,98	2,84	0,60	4,79	1,00	1,47	0,31	2,45	0,51	0,79	0,16	0,58	0,12	0,24	0,05
1500	1,50	0,38	21,64	3,40	6,41	1,01	16,49	2,59	4,90	0,77	9,47	1,49	2,84	0,45	4,79	0,75	1,47	0,23	2,45	0,38	0,79	0,12	0,58	0,09	0,24	0,04
1000	1,00	0,25	21,64	2,27	6,41	0,67	16,49	1,73	4,90	0,51	9,47	0,99	2,84	0,30	4,79	0,50	1,47	0,15	2,45	0,26	0,79	0,08	0,58	0,06	0,24	0,02
500	0,50	0,13	21,64	1,13	6,41	0,34	16,49	0,86	4,90	0,26	9,47	0,50	2,84	0,15	4,79	0,25	1,47	0,08	2,45	0,13	0,79	0,04	0,58	0,03	0,24	0,01

MH3-K-2505

n [1/min]	Stroke speed [m/min]		F=12,5 [kN]						F=10 [kN]						F=7,5 [kN]							
			6:1			24:1			6:1			24:1			6:1			24:1				
	H	L	Nm	HNm	kW	Nm	HNm	kW	Nm	HNm	kW	Nm	HNm	kW	Nm	HNm	kW	Nm	HNm	kW	Nm	HNm
3000	2,50	0,63	2,21	0,91	0,70	0,74	0,10	0,23	1,80	0,70	0,57	0,62	0,06	0,19	1,39	0,48	0,44	0,49	0,01	0,16		
2750	2,29	0,57	2,21	0,91	0,64	0,74	0,10	0,21	1,80	0,70	0,52	0,62	0,06	0,18	1,39	0,48	0,40	0,49	0,01	0,14		
2500	2,08	0,52	2,21	0,91	0,58	0,74	0,10	0,19	1,80	0,70	0,47	0,62	0,06	0,16	1,39	0,48	0,36	0,49	0,01	0,13		
2250	1,88	0,47	2,21	0,91	0,52	0,74	0,10	0,18	1,80	0,70	0,42	0,62	0,06	0,15	1,39	0,48	0,33	0,49	0,01	0,12		
2000	1,67	0,42	2,21	0,91	0,46	0,74	0,10	0,16	1,80	0,70	0,38	0,62	0,06	0,13	1,39	0,48	0,29	0,49	0,01	0,10		
1500	1,25	0,31	2,21	0,91	0,35	0,74	0,10	0,12	1,80	0,70	0,28	0,62	0,06	0,10	1,39	0,48	0,22	0,49	0,01	0,08		
1000	0,83	0,21	2,21	0,91	0,23	0,74	0,10	0,08	1,80	0,70	0,19	0,62	0,06	0,06	1,39	0,48	0,15	0,49	0,01	0,05		
500	0,42	0,10	2,21	0,91	0,12	0,74	0,10	0,04	1,80	0,70	0,09	0,62	0,06	0,03	1,39	0,48	0,07	0,49	0,01	0,03		

MH3-K-2505

n [1/min]	Stroke speed [m/min]		F=5 [kN]						F=2,5 [kN]						F=1 [kN]					
			6:1			24:1			6:1			24:1			6:1			24:1		
	H	L	Nm	HNm	kW	Nm	HNm	kW	Nm	HNm	kW	Nm	HNm	kW	Nm	HNm	kW	Nm	HNm	kW
3000	2,50	0,63	0,98	0,27	0,31	0,37	-	0,12	0,56	0,06	0,18	0,24	-	0,08	0,32	-	0,10	0,17	-	0,05
2750	2,29	0,57	0,98	0,27	0,28	0,37	-	0,11	0,56	0,06	0,16	0,24	-	0,07	0,32	-	0,09	0,17	-	0,05
2500	2,08	0,52	0,98	0,27	0,26	0,37	-	0,10	0,56	0,06	0,15	0,24	-	0,06	0,32	-	0,08	0,17	-	0,04
2250	1,88	0,47	0,98	0,27	0,23	0,37	-	0,09	0,56	0,06	0,13	0,24	-	0,06	0,32	-	0,07	0,17	-	0,04
2000	1,67	0,42	0,98	0,27	0,20	0,37	-	0,08	0,56	0,06	0,12	0,24	-	0,05	0,32	-	0,07	0,17	-	0,04
1500	1,25	0,31	0,98	0,27	0,15	0,37	-	0,06	0,56	0,06	0,09	0,24	-	0,04	0,32	-	0,05	0,17	-	0,03
1000	0,83	0,21	0,98	0,27	0,10	0,37	-	0,04	0,56	0,06	0,06	0,24	-	0,03	0,32	-	0,03	0,17	-	0,02
500	0,42	0,10	0,98	0,27	0,05	0,37	-	0,02	0,56	0,06	0,03	0,24	-	0,01	0,32	-	0,02	0,17	-	0,01

Performance Data

High-Performance Screw Jacks MH/JH

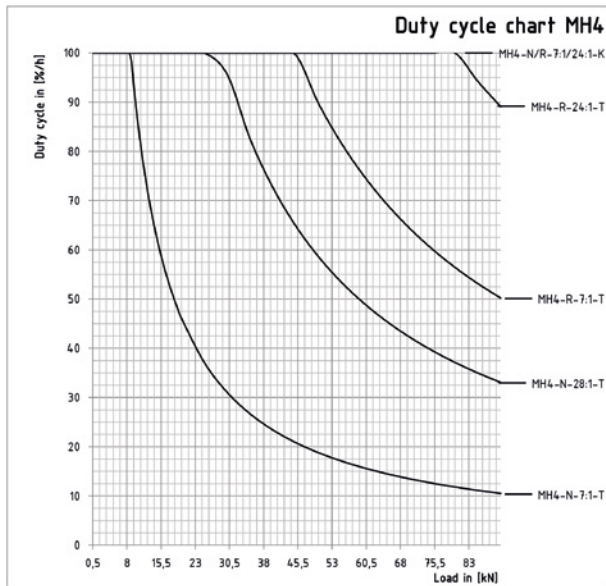

Duty cycle chart for 1500 1/min and 20° C temperature.

To calculate the Operating time ED_n/h for other speeds, multiply the Operating time in [%] with the speed-factor fn_{neff} :

$$ED_n/h \text{ in } [\%] = ED_d/h \times fn_{neff}$$

If different speeds determine the average of speed:

$$n_m = n_1 \times q_1 + n_2 \times q_2 + \dots + n_i \times q_i / 100$$

n_1, n_2, \dots = Speed in [1/min] during the clearance

q_1, q_2, \dots = Dues of load duration in [%]

n_m = Average speed in [1/min]

speed	speed factor fn_{neff}
3000	0,5
2500	0,6
2000	0,75
1000	1,5
750	2
500	3
250	6

MH4-T-40x7																										
n [1/ min]	Stroke speed [m/min]		F=88 [kN]				F=60 [kN]				F=40 [kN]				F=20 [kN]				F=10 [kN]				F=5 [kN]			
			7:1		28:1		7:1		28:1		7:1		28:1		7:1		28:1		7:1		28:1		7:1		28:1	
	H	L	Nm	kW	Nm	kW	Nm	kW	Nm	kW	Nm	kW	Nm	kW	Nm	kW	Nm	kW	Nm	kW	Nm	kW	Nm	kW	Nm	kW
3000	3,00	0,75	44,12	13,86	12,76	4,01	30,19	9,48	8,78	2,76	20,24	6,36	5,93	1,86	10,30	3,23	3,09	0,97	5,32	1,67	1,67	0,52	2,84	0,09	0,96	0,30
2750	2,75	0,69	44,12	12,70	12,76	3,67	30,19	8,69	8,78	2,53	20,24	5,83	5,93	1,71	10,30	2,97	3,09	0,89	5,32	1,53	1,67	0,48	2,84	0,09	0,96	0,28
2500	2,50	0,63	44,12	11,55	12,76	3,34	30,19	7,90	8,78	2,30	20,24	5,30	5,93	1,55	10,30	2,70	3,09	0,81	5,32	1,39	1,67	0,44	2,84	0,09	0,96	0,25
2250	2,25	0,56	44,12	10,39	12,76	3,01	30,19	7,11	8,78	2,07	20,24	4,77	5,93	1,40	10,30	2,43	3,09	0,73	5,32	1,25	1,67	0,39	2,84	0,09	0,96	0,23
2000	2,00	0,50	44,12	9,24	12,76	2,67	30,19	6,32	8,78	1,84	20,24	4,24	5,93	1,24	10,30	2,16	3,09	0,65	5,32	1,11	1,67	0,35	2,84	0,09	0,96	0,20
1500	1,50	0,38	44,12	6,93	12,76	2,00	30,19	4,74	8,78	1,38	20,24	3,18	5,93	0,93	10,30	1,62	3,09	0,49	5,32	0,84	1,67	0,26	2,84	0,09	0,96	0,15
1000	1,00	0,25	44,12	4,62	12,76	1,34	30,19	3,16	8,78	0,92	20,24	2,12	5,93	0,62	10,30	1,08	3,09	0,32	5,32	0,56	1,67	0,17	2,84	0,09	0,96	0,10
500	0,50	0,13	44,12	2,31	12,76	0,67	30,19	1,58	8,78	0,46	20,24	1,06	5,93	0,31	10,30	0,54	3,09	0,16	5,32	0,28	1,67	0,09	2,84	0,09	0,96	0,05

MH4-K-4005																				
n [1/min]	Stroke speed [m/min]		F=24 [kN]						F=20 [kN]						F=15 [kN]					
			7:1			28:1			7:1			28:1			7:1			28:1		
	H	L	Nm	HNm	kW	Nm	HNm	kW	Nm	HNm	kW	Nm	HNm	kW	Nm	HNm	kW	Nm	HNm	kW
3000	2,14	0,54	3,83	1,34	1,20	1,29	0,11	0,41	3,25	1,06	1,02	1,12	0,05	0,35	2,52	0,71	0,79	0,89	-0,02	0,28
2750	1,96	0,49	3,83	1,34	1,10	1,29	0,11	0,37	3,25	1,06	0,94	1,12	0,05	0,32	2,52	0,71	0,73	0,89	-0,02	0,26
2500	1,79	0,45	3,83	1,34	1,00	1,29	0,11	0,34	3,25	1,06	0,85	1,12	0,05	0,29	2,52	0,71	0,66	0,89	-0,02	0,23
2250	1,61	0,40	3,83	1,34	0,90	1,29	0,11	0,30	3,25	1,06	0,77	1,12	0,05	0,26	2,52	0,71	0,59	0,89	-0,02	0,21
2000	1,43	0,36	3,83	1,34	0,80	1,29	0,11	0,27	3,25	1,06	0,68	1,12	0,05	0,23	2,52	0,71	0,53	0,89	-0,02	0,19
1500	1,07	0,27	3,83	1,34	0,60	1,29	0,11	0,20	3,25	1,06	0,51	1,12	0,05	0,18	2,52	0,71	0,40	0,89	-0,02	0,14
1000	0,71	0,18	3,83	1,34	0,40	1,29	0,11	0,14	3,25	1,06	0,34	1,12	0,05	0,12	2,52	0,71	0,26	0,89	-0,02	0,09
500	0,36	0,09	3,83	1,34	0,20	1,29	0,11	0,07	3,25	1,06	0,17	1,12	0,05	0,06	2,52	0,71	0,13	0,89	-0,02	0,05

MH4-K-4005																				
n [1/min]	Stroke speed [m/min]		F=10 [kN]						F=7,5 [kN]						F=5 [kN]					
			7:1			28:1			7:1			28:1			7:1			28:1		
	H	L	Nm	HNm	kW	Nm	HNm	kW	Nm	HNm	kW	Nm	HNm	kW	Nm	HNm	kW	Nm	HNm	kW
3000	2,14	0,54	1,80	0,36	0,57	0,68	-	0,21	1,44	0,18	0,45	0,58	-	0,18	1,07	-	0,34	0,47	-	0,15
2750	1,96	0,49	1,80	0,36	0,52	0,68	-	0,20	1,44	0,18	0,41	0,58	-	0,17	1,07	-	0,31	0,47	-	0,13
2500	1,79	0,45	1,80	0,36	0,47	0,68	-	0,18	1,44	0,18	0,38	0,58	-	0,15	1,07	-	0,28	0,47	-	0,12
2250	1,61	0,40	1,80	0,36	0,42	0,68	-	0,16	1,44	0,18	0,34	0,58	-	0,14	1,07	-	0,25	0,47	-	0,11
2000	1,43	0,36	1,80	0,36	0,38	0,68	-	0,14	1,44	0,18	0,30	0,58	-	0,12	1,07	-	0,22	0,47	-	0,10
1500	1,07	0,27	1,80	0,36	0,28	0,68	-	0,11	1,44	0,18	0,23	0,58	-	0,09	1,07	-	0,17	0,47	-	0,07
1000	0,71	0,18	1,80	0,36	0,19	0,68	-	0,07	1,44	0,18	0,15	0,58	-	0,06	1,07	-	0,11	0,47	-	0,05
500	0,36	0,09	1,80	0,36	0,09	0,68	-	0,04	1,44	0,18	0,08	0,58	-	0,03	1,07	-	0,06	0,47	-	0,02

Performance Data

High-Performance Screw Jacks MH/JH

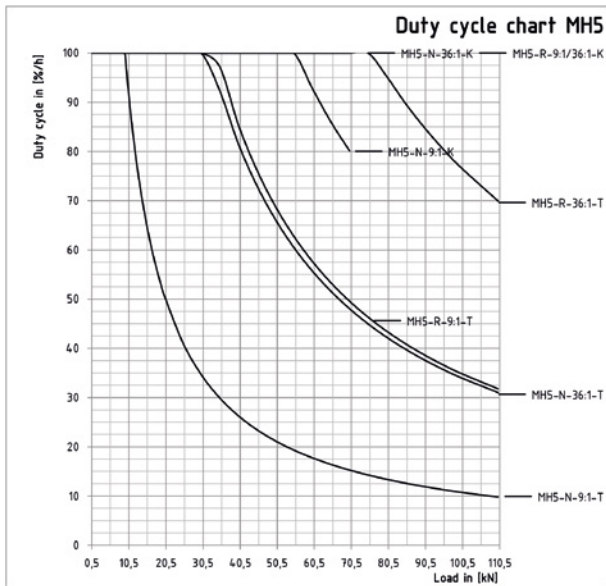

Duty cycle chart for 1500 1/min and 20° C temperature.

To calculate the Operating time ED_n/h for other speeds, multiply the Operating time in [%] with the speed-factor fn_{neff} :

$$ED_n/h \text{ in } [\%] = ED_d/h \times fn_{neff}$$

If different speeds determine the average of speed:

$$n_m = n_1 \times q_1 + n_2 \times q_2 + \dots + n_i \times q_i / 100$$

n_1, n_2, \dots = Speed in [1/min] during the clearance

q_1, q_2, \dots = Dues of load duration in [%]

n_m = Average speed in [1/min]

speed	speed factor fn_{neff}
3000	0,5
2500	0,6
2000	0,75
1000	1,5
750	2
500	3
250	6

MH5-T-55x9

n [1/ min]	Stroke speed [m/min]		F=106 [kN]				F=80 [kN]				F=60 [kN]				F=40 [kN]				F=20 [kN]				F=10 [kN]			
			9:1		36:1		9:1		36:1		9:1		36:1		9:1		36:1		9:1		36:1		9:1		36:1	
	H	L	Nm	kW	Nm	kW	Nm	kW	Nm	kW	Nm	kW	Nm	kW	Nm	kW	Nm	kW	Nm	kW	Nm	kW	Nm	kW	Nm	kW
3000	3,00	0,75	62,8	19,7	17,8	5,6	47,5	14,9	13,5	4,2	35,7	11,2	10,2	3,2	23,9	7,5	6,9	2,2	12,1	3,8	3,6	1,1	6,2	0,1	1,9	0,6
2750	2,75	0,69	62,8	18,1	17,8	5,1	47,5	13,7	13,5	3,9	35,7	10,3	10,2	2,9	23,9	6,9	6,9	2,0	12,1	3,5	3,6	1,0	6,2	0,1	1,9	0,5
2500	2,50	0,62	62,8	16,4	17,8	4,7	47,5	12,4	13,5	3,5	35,7	9,4	10,2	2,7	23,9	6,3	6,9	1,8	12,1	3,2	3,6	0,9	6,2	0,1	1,9	0,5
2250	2,25	0,56	62,8	14,8	17,8	4,2	47,5	11,2	13,5	3,2	35,7	8,4	10,2	2,4	23,9	5,6	6,9	1,6	12,1	2,9	3,6	0,8	6,2	0,1	1,9	0,4
2000	2,00	0,50	62,8	13,2	17,8	3,7	47,5	9,9	13,5	2,8	35,7	7,5	10,2	2,1	23,9	5,0	6,9	1,4	12,1	2,5	3,6	0,7	6,2	0,1	1,9	0,4
1500	1,50	0,38	62,8	9,9	17,8	2,8	47,5	7,5	13,5	2,1	35,7	5,6	10,2	1,6	23,9	3,8	6,9	1,1	12,1	1,9	3,6	0,6	6,2	0,1	1,9	0,3
1000	1,00	0,25	62,8	6,6	17,8	1,9	47,5	5,0	13,5	1,4	35,7	3,7	10,2	1,1	23,9	2,5	6,9	0,7	12,1	1,3	3,6	0,4	6,2	0,1	1,9	0,2
500	0,50	0,13	62,8	3,3	17,8	0,9	47,5	2,5	13,5	0,7	35,7	1,9	10,2	0,5	23,9	1,3	6,9	0,4	12,1	0,6	3,6	0,2	6,2	0,1	1,9	0,1

MH5-K-5010

n [1/min]	Stroke speed [m/min]		F=69 [kN]						F=60 [kN]						F=40 [kN]							
			9:1			36:1			9:1			36:1			9:1			36:1				
	H	L	Nm	HNm	kW	Nm	HNm	kW	Nm	HNm	kW	Nm	HNm	kW	Nm	HNm	kW	Nm	HNm	kW	Nm	HNm
3000	4,29	1,07	22,78	8,44	7,16	6,84	1,65	2,15	19,86	7,30	6,24	5,98	1,40	1,88	13,36	4,75	4,20	4,07	0,85	1,28		
2750	3,93	0,98	22,78	8,44	6,56	6,84	1,65	1,97	19,86	7,30	5,72	5,98	1,40	1,72	13,36	4,75	3,85	4,07	0,85	1,17		
2500	3,57	0,89	22,78	8,44	5,96	6,84	1,65	1,79	19,86	7,30	5,20	5,98	1,40	1,57	13,36	4,75	3,50	4,07	0,85	1,07		
2250	3,21	0,80	22,78	8,44	5,37	6,84	1,65	1,61	19,86	7,30	4,68	5,98	1,40	1,41	13,36	4,75	3,15	4,07	0,85	0,96		
2000	2,86	0,71	22,78	8,44	4,77	6,84	1,65	1,43	19,86	7,30	4,16	5,98	1,40	1,25	13,36	4,75	2,80	4,07	0,85	0,85		
1500	2,14	0,54	22,78	8,44	3,58	6,84	1,65	1,07	19,86	7,30	3,12	5,98	1,40	0,94	13,36	4,75	2,10	4,07	0,85	0,64		
1000	1,43	0,36	22,78	8,44	2,39	6,84	1,65	0,72	19,86	7,30	2,08	5,98	1,40	0,63	13,36	4,75	1,40	4,07	0,85	0,43		
500	0,71	0,18	22,78	8,44	1,19	6,84	1,65	0,36	19,86	7,30	1,04	5,98	1,40	0,31	13,36	4,75	0,70	4,07	0,85	0,21		

MH5-K-5010

n [1/min]	Stroke speed [m/min]		F=20 [kN]						F=10 [kN]						F=5 [kN]					
			9:1			36:1			9:1			36:1			9:1			36:1		
	H	L	Nm	HNm	kW	Nm	HNm	kW	Nm	HNm	kW	Nm	HNm	kW	Nm	HNm	kW	Nm	HNm	kW
3000	4,29	1,07	6,85	2,20	2,15	2,16	0,30	0,68	3,60	0,92	1,13	1,20	0,03	0,38	1,98	0,29	0,62	0,73	-	0,23
2750	3,93	0,98	6,85	2,20	1,97	2,16	0,30	0,62	3,60	0,92	1,04	1,20	0,03	0,35	1,98	0,29	0,57	0,73	-	0,21
2500	3,57	0,89	6,85	2,20	1,79	2,16	0,30	0,57	3,60	0,92	0,94	1,20	0,03	0,32	1,98	0,29	0,52	0,73	-	0,19
2250	3,21	0,80	6,85	2,20	1,61	2,16	0,30	0,51	3,60	0,92	0,85	1,20	0,03	0,28	1,98	0,29	0,47	0,73	-	0,17
2000	2,86	0,71	6,85	2,20	1,44	2,16	0,30	0,45	3,60	0,92	0,75	1,20	0,03	0,25	1,98	0,29	0,41	0,73	-	0,15
1500	2,14	0,54	6,85	2,20	1,08	2,16	0,30	0,34	3,60	0,92	0,57	1,20	0,03	0,19	1,98	0,29	0,31	0,73	-	0,11
1000	1,43	0,36	6,85	2,20	0,72	2,16	0,30	0,23	3,60	0,92	0,38	1,20	0,03	0,13	1,98	0,29	0,21	0,73	-	0,08
500	0,71	0,18	6,85	2,20	0,36	2,16	0,30	0,11	3,60	0,92	0,19	1,20	0,03	0,06	1,98	0,29	0,10	0,73	-	0,04

Performance Data

High-Performance Screw Jacks MH/JH

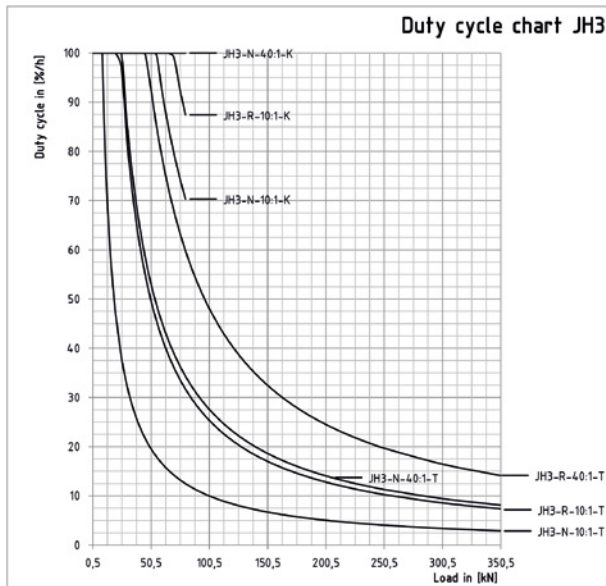

Duty cycle chart for 1500 1/min and 20° C temperature.

To calculate the Operating time ED_n/h for other speeds, multiply the Operating time in [%] with the speed-factor fn_{neff} :

$$ED_n/h \text{ in } [\%] = ED_d/h \times fn_{neff}$$

If different speeds determine the average of speed:

$$n_m = n_1 \times q_1 + n_2 \times q_2 + \dots + n_i \times q_i / 100$$

n_1, n_2, \dots = Speed in [1/min] during the clearance

q_1, q_2, \dots = Dues of load duration in [%]

n_m = Average speed in [1/min]

speed	speed factor fn_{neff}
3000	0,5
2500	0,6
2000	0,75
1000	1,5
750	2
500	3
250	6

JH3-K-8010

n [1/min]	Stroke speed [m/min]		F=82 [kN]						F=70 [kN]						F=60 [kN]					
			10:1			40:1			10:1			40:1			10:1			40:1		
	H	L	Nm	HNm	kW	Nm	HNm	kW	Nm	HNm	kW	Nm	HNm	kW	Nm	HNm	kW	Nm	HNm	kW
3000	3,33	0,83	23,07	4,94	7,25	8,22	0,20	2,58	19,89	4,03	6,25	7,16	0,03	2,25	17,24	3,26	5,41	6,28	-	1,97
2750	3,06	0,76	23,07	4,94	6,64	8,22	0,20	2,37	19,89	4,03	5,73	7,16	0,03	2,06	17,24	3,26	4,96	6,28	-	1,81
2500	2,78	0,69	23,07	4,94	6,04	8,22	0,20	2,15	19,89	4,03	5,21	7,16	0,03	1,87	17,24	3,26	4,51	6,28	-	1,64
2250	2,50	0,63	23,07	4,94	5,44	8,22	0,20	1,94	19,89	4,03	4,69	7,16	0,03	1,69	17,24	3,26	4,06	6,28	-	1,48
2000	2,22	0,56	23,07	4,94	4,83	8,22	0,20	1,72	19,89	4,03	4,17	7,16	0,03	1,50	17,24	3,26	3,61	6,28	-	1,31
1500	1,67	0,42	23,07	4,94	3,62	8,22	0,20	1,29	19,89	4,03	3,12	7,16	0,03	1,12	17,24	3,26	2,71	6,28	-	0,99
1000	1,11	0,28	23,07	4,94	2,42	8,22	0,20	0,86	19,89	4,03	2,08	7,16	0,03	0,75	17,24	3,26	1,80	6,28	-	0,66
500	0,56	0,14	23,07	4,94	1,21	8,22	0,20	0,43	19,89	4,03	1,04	7,16	0,03	0,37	17,24	3,26	0,90	6,28	-	0,33

JH3-K-8010

n [1/min]	Stroke speed [m/min]		F=40 [kN]						F=20 [kN]						F=10 [kN]					
			10:1			40:1			10:1			40:1			10:1			40:1		
	H	L	Nm	HNm	kW	Nm	HNm	kW	Nm	HNm	kW	Nm	HNm	kW	Nm	HNm	kW	Nm	HNm	kW
3000	3,33	0,83	11,93	1,74	3,75	4,51	-	1,42	6,63	0,21	2,08	2,74	-	0,86	3,97	-	1,25	1,85	-	0,58
2750	3,06	0,76	11,93	1,74	3,44	4,51	-	1,30	6,63	0,21	1,91	2,74	-	0,79	3,97	-	1,14	1,85	-	0,53
2500	2,78	0,69	11,93	1,74	3,12	4,51	-	1,18	6,63	0,21	1,73	2,74	-	0,72	3,97	-	1,04	1,85	-	0,49
2250	2,50	0,63	11,93	1,74	2,81	4,51	-	1,06	6,63	0,21	1,56	2,74	-	0,65	3,97	-	0,94	1,85	-	0,44
2000	2,22	0,56	11,93	1,74	2,50	4,51	-	0,94	6,63	0,21	1,39	2,74	-	0,57	3,97	-	0,83	1,85	-	0,39
1500	1,67	0,42	11,93	1,74	1,87	4,51	-	0,71	6,63	0,21	1,04	2,74	-	0,43	3,97	-	0,62	1,85	-	0,29
1000	1,11	0,28	11,93	1,74	1,25	4,51	-	0,47	6,63	0,21	0,69	2,74	-	0,29	3,97	-	0,42	1,85	-	0,19
500	0,56	0,14	11,93	1,74	0,62	4,51	-	0,24	6,63	0,21	0,35	2,74	-	0,14	3,97	-	0,21	1,85	-	0,10

JH3-T-80x10

n [1/min]	Stroke speed [m/min]		F=350 [kN]				F=200 [kN]				F=100 [kN]				F=50 [kN]				F=20 [kN]				F=10 [kN]			
			4:1		16:1		10:1		40:1		10:1		40:1		10:1		40:1		10:1		40:1		10:1		40:1	
	H	L	Nm	kW	Nm	kW	Nm	kW	Nm	kW	Nm	kW	Nm	kW	Nm	kW	Nm	kW	Nm	kW	Nm	kW	Nm	kW	Nm	kW
3000	3,00	0,75	279,8	87,9	93,8	29,5	160,5	50,4	54,0	17,0	80,9	25,4	27,5	8,6	41,1	12,9	14,2	4,5	17,2	5,4	6,3	2,0	9,3	0,1	3,6	1,1
2750	2,75	0,69	279,8	80,6	93,8	27,0	160,5	46,2	54,0	15,6	80,9	23,3	27,5	7,9	41,1	11,8	14,2	4,1	17,2	5,0	6,3	1,8	9,3	0,1	3,6	1,0
2500	2,50	0,63	279,8	73,3	93,8	24,6	160,5	42,0	54,0	14,1	80,9	21,2	27,5	7,2	41,1	10,8	14,2	3,7	17,2	4,5	6,3	1,6	9,3	0,1	3,6	0,9
2250	2,25	0,56	279,8	65,9	93,8	22,1	160,5	37,8	54,0	12,7	80,9	19,1	27,5	6,5	41,1	9,7	14,2	3,4	17,2	4,1	6,3	1,5	9,3	0,1	3,6	0,9
2000	2,00	0,50	279,8	58,6	93,8	19,6	160,5	33,6	54,0	11,3	80,9	16,9	27,5	5,8	41,1	8,6	14,2	3,0	17,2	3,6	6,3	1,3	9,3	0,1	3,6	0,8
1500	1,50	0,38	279,8	44	93,8	14,7	160,5	25,2	54,0	8,5	80,9	12,7	27,5	4,3	41,1	6,5	14,2	2,2	17,2	2,7	6,3	1,0	9,3	0,1	3,6	0,6
1000	1,00	0,25	279,8	29,3	93,8	9,8	160,5	16,8	54,0	5,7	80,9	8,5	27,5	2,9	41,1	4,3	14,2	1,5	17,2	1,8	6,3	0,7	9,3	0,1	3,6	0,4
500	0,50	0,13	279,8	14,7	93,8	4,9	160,5	8,4	54,0	2,8	80,9	4,2	27,5	1,4	41,1	2,2	14,2	0,7	17,2	0,9	6,3	0,3	9,3	0,1	3,6	0,2

Ordering Code

High-Performance Screw Jacks MH/JH

1	2	3	4	5	6	7	8	9	10	11	12	13	

No.	Designation	Code	Description
1	Size	MH1, MH2, ...	
		JH3	
2	Design	N	Lifting Screw
		VK	Lifting screw, protected against twisting by square tube
		R	Rotating screw
3	Transmission ratio	4:1 / 16:1	M0, M1, M2
		6:1 / 24:1	M3
		7:1 / 28:1	M4
		9:1 / 36:1	M5 und J1
		10:1 / 40:1	J2, J3, J4
4	Type of screw	T	Trapezoidal screw drive
		K	Ball screw drive
5	Screw dimension		e.g. 2005 = diameter 20mm, pitch 5mm
6	Stroke in [mm]		Specification of the stroke length
7	Screw extension VL in [mm] for N/VK design		Screw extension VL, usable stroke length NL e.g. due to block, mounting situation. See product drawings
	Usable stroke length NL in [mm] for R design		
8	Screw end	M	Metric threaded stem
		A	End with chamfer
		S	Custom (according to specification, description or drawing)
		Z	Centric stem (standard for version R)
9	Attached part for version N/VK	O	None
		BP	With fastening plate mounted
		GA	With spherical bearing mounted
		GK	With fork end mounted
		HG	With high-performance fork end mounted
	Nut type for version R (other nut types on request)	F-D	Flanged nut according DIN 69051 (flange direction to housing)
		F-N	Flanged nut according Neff-Norm (flange direction to housing)
		D-F	Flanged nut according DIN 69051 (flange direction to screw end)
		N-F	Flanged nut according Neff-Norm (flange direction to screw end)
		EFM-N	trapezoidal-threaded nut to NEFF-Norm (flange direction to housing)
		N-EFM	trapezoidal-threaded nut to NEFF-Norm (flange direction to screw end)
		SFF-N	safety nut - flange side to NEFF-Norm (flange direction to housing)
		N-SFF	safety nut - flange side to NEFF-Norm (flange direction to screw end)
		SFZ-N	safety nut - centric side to NEFF-Norm (flange direction to housing)
N-SFZ	safety nut - centric side to NEFF-Norm (flange direction to screw end)		
10	Screw cover	O	None
		FB	With bellow
		SF	With spiral spring cover
11	Anti-unscrewing device	O	None
		AS	With (installed as standard with ball screw drive)
12	Shaft ends	O	Two shaft ends side A+B (Standard)
		A	Shaft end side A
		B	Shaft end side B
13	Special requirements	O	None
		1	According to specification, description or drawing

High-speed screw jacks G1-G3

High Speed Screw Jack G1-G3

NEFF high speed screw jacks supplement our offer of worm gear screw jacks. They are more efficient and may be used in a broader field of applications. They may be used in a medium load range (12.3 kN-117 kN1), with a high lifting speed and longer operating time.

All high speed screw jacks are equipped with hardened, sharpened and spiral-toothed bevel gear transmissions. Therefore, they attain high lifting speeds and improved efficiency.

The models N, V and R are available in three sizes with 2:1 and 3:1 transmissions. With ball screws, high speed screw jacks become even

more dynamic. All high speed screw jacks work in all installation positions. Due to their cubic casing they can be mounted flexibly.

By using ball screws the high-speed screw jacks achieve even better performance values. All high-speed screw jacks are functional in every installation position and can be mounted flexibly thanks to the cubic form of the housing.

According to the customer's request they are delivered with up to four drive shafts. Lifting assemblies with several high speed screw jacks do not therefore require additional bevel gears.

Technical Data Version N/VK:							
Size ⁷⁾	G1-N-VK-TGS 24x5	G1-N-VK-KGS 2505	G2-N-VK-TGS 40x7	G2-N-VK-KGS 3210	G2-N-VK-KGS 4005	G3-N-VK-TGS 60x9	G3-N-VK-KGS 6310
Max. stroke and drag force in [kN]	20,6	12,3	44,5	33,4	23,8	117	76
Stroke per full turn of the screw shaft, ratio 2:1 in [mm] ⁸⁾	2,5	2,5	3,5	5	2,5	4,5	5
Stroke per full turn of the screw shaft, ratio 3:1 in [mm] ⁸⁾	1,6	1,6	2,3	3,33	1,6	3	3,33
Max. stroke speed in m/min ratio 2:1, 3000/min	· ¹⁾	7,5	· ²⁾	15	7,5	· ³⁾	15
Max. stroke speed in m/min ratio 3:1, 3000/min	· ⁴⁾	5,01	· ⁵⁾	10	4,99	· ⁶⁾	9,99
Efficiency (with screw)	0,45	0,75	0,4	0,75	0,75	0,35	0,75
Gear efficiency	0,91	0,91	0,93	0,93	0,93	0,94	0,94
Idling torque for ratio 2:1	1,44	1,44	1,89	1,89	1,89	3,69	3,69
Idling torque for ratio 3:1	1,35	1,35	1,8	1,8	1,8	3,6	3,6
Max. moment of a torque on the screw shaft in [Nm]	50	50	175	175	175	1600	1600

Technical Data Version R:							
Size ⁷⁾	G1-R-TGS 24x5	G1-R-KGS 2505	G2-R-TGS 40x7	G2-R-KGS 3210	G2-R-KGS 4005	G3-R-TGS 60x9	G3-R-KGS 6310
Max. stroke and drag force in [kN]	19,6	12,3	56,5	33,4	23,8	117	76
Stroke per full turn of the screw shaft, ratio 2:1 in [mm] ⁸⁾	2,5	2,5	3,5	5	2,5	4,5	5
Stroke per full turn of the screw shaft, ratio 3:1 in [mm] ⁸⁾	1,6	1,6	2,3	3,33	1,6	3	3,33
Max. stroke speed in m/min ratio 2:1, 3000/min	· ¹⁾	7,5	· ²⁾	15	7,5	· ³⁾	15
Max. stroke speed in m/min ratio 3:1, 3000/min	· ⁴⁾	5,01	· ⁵⁾	10	4,99	· ⁶⁾	9,99
Efficiency (with screw)	0,45	0,75	0,4	0,75	0,75	0,35	0,75
Gear efficiency	0,91	0,91	0,93	0,93	0,93	0,94	0,94
Idling torque for ratio 2:1	1,44	1,44	1,89	1,89	1,89	3,69	3,69
Idling torque for ratio 3:1	1,35	1,35	1,8	1,8	1,8	3,6	3,6
Max. moment of a torque on the screw shaft in [Nm]	50	50	175	175	175	1600	1600

- 1) max. permissible screw revolution speed (max. 4,55m/min at 1820/min)
- 2) max. permissible screw revolution speed (max. 1,82m/min at 520/min)
- 3) max. permissible screw revolution speed (max. 1,44m/min at 320/min)
- 4) max. permissible screw revolution speed (max. 4,55m/min at 2730/min)

- 5) max. permissible screw revolution speed (max. 1,82m/min at 780/min)
- 6) max. permissible screw revolution speed (max. 1,44m/min at 460/min)
- 7) all screw sizes with other threads in stock
- 8) ratio 1:1 on request

High-speed screw jacks

Dimensions - type R

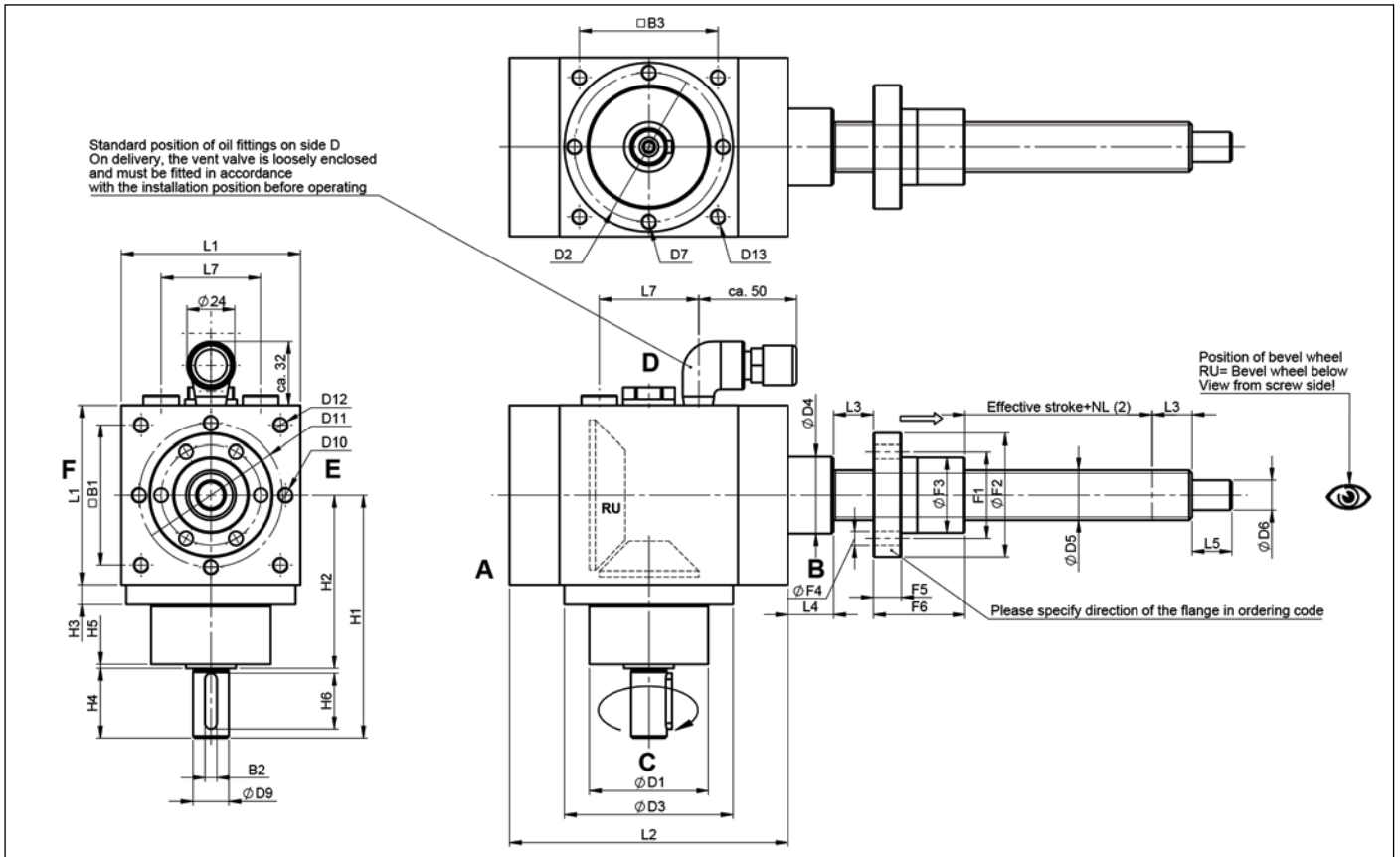

Size	L1	L2	L3	L4	L5	L7	B1	B2	B3	H1	H2	H3	H4	H5	H6	D1	D2	D3 h7
G1	90	140	20	23	25	50	-	6	-	122	87	10	35	2	25	60	75	89
G2	140	190	25	32	30	90	113	10	110	180	130	13	50	2	45	90	-	135
G3	230	295	40	40	55	180	-	16/12 ¹⁾	180	305/310 ¹⁾	215/230 ¹⁾	17	90/80 ¹⁾	7,5	80/63 ¹⁾	150/120 ¹⁾	-	225

Size	D4	D5	D6 j6	D7	D9 j6	D10	D11	D12	D13	F1	F2	F3	F4	F5	F6
G1	39	T24x5/K2505	20	M8	18/12 ¹⁾	M10	72	-	-	50	62	38	7	14	44/46 ³⁾
G2	60	T40x7/K4005	25	-	32/28 ¹⁾	-	-	M12	M10	68	80	53	7	16	73/59 ³⁾
G3	90	T60x9/K6310	45	-	55/40 ¹⁾	M20	180	-	M16	105	125	85	11	20	99

1) First dimension for ratio 2:1, second dimension for ratio 3:1

2) NL: Usable stroke length (see product code)

3) First dimension for apezoidal screw, second dimension for ball screw

High-speed screw jacks G1

Dimensions - type N/V

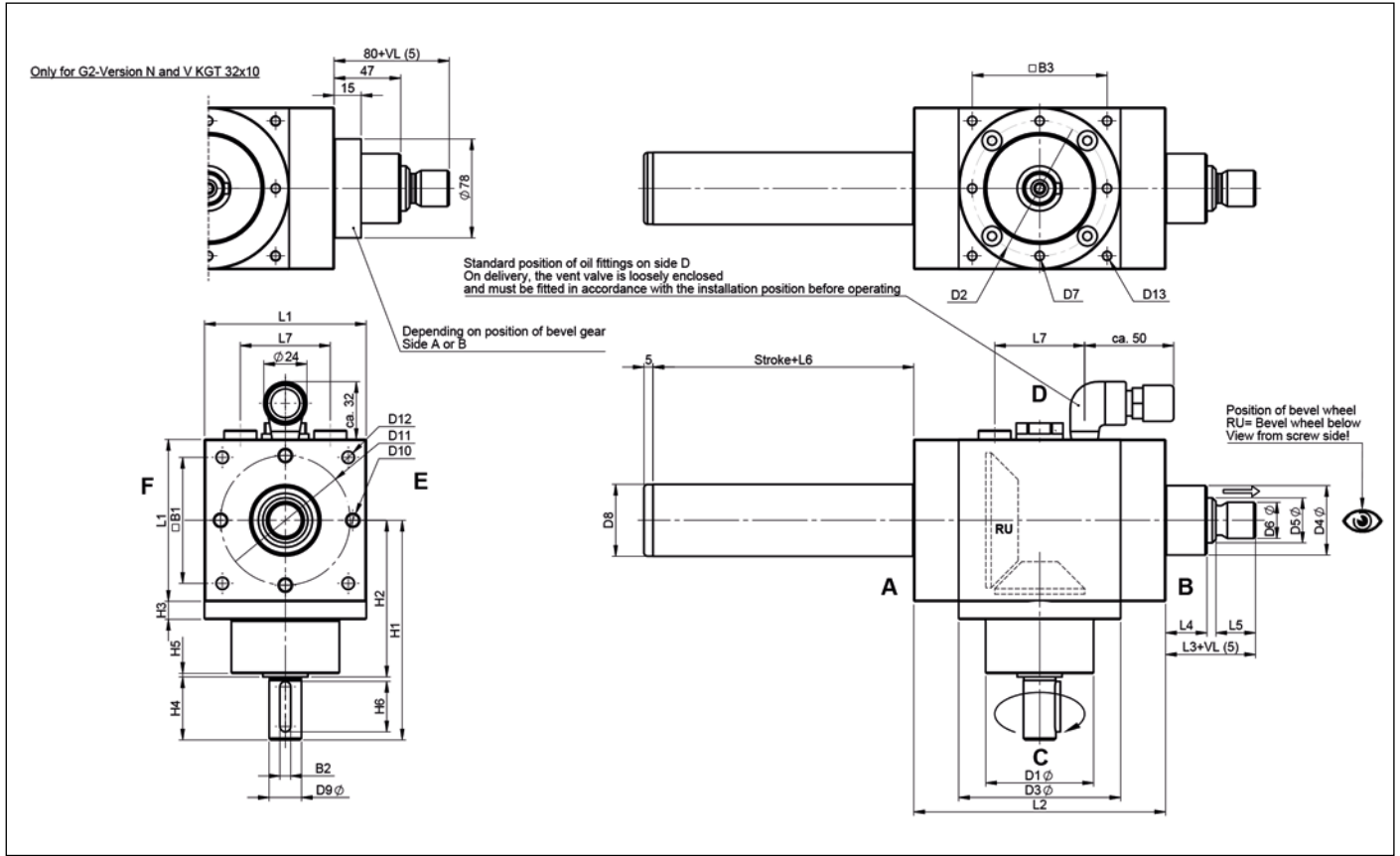

Size	L1	L2	L3	L4	L5	L6	L7	B1	B2	B3	H1	H2	H3	H4	H5	H6	D1	D2	D3 h7
G1	90	140	50	23	22	35/70 ⁴	50	-	6	-	122	87	10	35	2	25	60	75	89
G2	140	190	65	32	29	45/100 ⁴	90	113	10	110	180	130	13	50	2	45	90	-	135
G3	230	295	95	40	48	60/110 ⁴	180	-	16/12 ¹	180	305/310 ¹	215/230 ¹	17,5	90/80 ¹	2/3,5 ¹	80/63 ¹	150/120 ¹	-	225

Size	D4	D5	D6	D7	D8	D9 j6	D10	D11	D12	D13
G1	39	T24x5/K2505	M18/M20 ³	M8	42/□40 ²	18/12 ¹	M10	72	-	-
G2	60	T40x7/K4005	M30/M20 ³	-	65/□65 ²	32/28 ¹	-	-	M12	M10
G3	90	T60x9/K6310	M48x2 ³	-	90/□90 ²	55/40 ¹	M20	180	-	M16

1) First dimension for ratio 2:1, second dimension for ratio 3:1

2) First dimension for Standard-Version N, second dimension for square-type tube Version V

3) First dimension for trapezoidal screw, second dimension for ball screw

4) Second dimension for stop collar or locking device

5) Screw extension (see productcode)

Performance table

- F** Axial load
- H** Low ratio (ex.: 2:1)
- L** High ratio (ex.: 3:1)
- Nm** Required drive torque for axial load **F**
- HNm** Required holding torque for axial load **F** (If – no holding torque is required)
- kW** Required driving power in depending on speed

Screw jacks with other screw pitches as in the performance tables:

For screws with higher pitches the power values can be multiplied by the pitch factor.

For example: If a pitch of 10 mm in place of 5 mm use the existing performance data and multiply by the factor of 2, use a factor of 10 if the pitch is 50 mm in place of 5 mm

G1-KGS-2505																																
n [1/min]	Stroke speed [m/min]		F=15 [kN]						F=10 [kN]						F=5 [kN]						F=2,5 [kN]						F=1 [kN]					
			2:1			3:1			2:1			3:1			2:1			3:1			2:1			3:1			2:1			3:1		
	2:1	3:1	Nm	HNm	kW	Nm	HNm	kW	Nm	HNm	kW	Nm	HNm	kW	Nm	HNm	kW	Nm	HNm	kW	Nm	HNm	kW	Nm	HNm	kW	Nm	HNm	kW			
3000	7,50	5,00	9,76	2,68	3,07	6,79	1,16	2,13	7,11	1,18	2,23	5,10	0,21	1,60	4,45	-	1,40	3,40	-	1,07	3,13	-	0,98	2,55	-	0,80	2,33	-	0,73	2,04	-	0,64
2250	5,63	3,75	9,76	2,68	2,30	6,79	1,16	1,60	7,11	1,18	1,67	5,10	0,21	1,20	4,45	-	1,05	3,40	-	0,80	3,13	-	0,74	2,55	-	0,60	2,33	-	0,55	2,04	-	0,48
1500	3,75	2,50	9,76	2,68	1,53	6,79	1,16	1,07	7,11	1,18	1,12	5,10	0,21	0,80	4,45	-	0,70	3,40	-	0,53	3,13	-	0,49	2,55	-	0,40	2,33	-	0,37	2,04	-	0,32
1000	2,50	1,67	9,76	2,68	1,02	6,79	1,16	0,71	7,11	1,18	0,74	5,10	0,21	0,53	4,45	-	0,47	3,40	-	0,36	3,13	-	0,33	2,55	-	0,27	2,33	-	0,24	2,04	-	0,21
750	1,88	1,25	9,76	2,68	0,77	6,79	1,16	0,53	7,11	1,18	0,56	5,10	0,21	0,40	4,45	-	0,35	3,40	-	0,27	3,13	-	0,25	2,55	-	0,20	2,33	-	0,18	2,04	-	0,16
500	1,25	0,83	9,76	2,68	0,51	6,79	1,16	0,36	7,11	1,18	0,37	5,10	0,21	0,27	4,45	-	0,23	3,40	-	0,18	3,13	-	0,16	2,55	-	0,13	2,33	-	0,12	2,04	-	0,10
250	0,63	0,42	9,76	2,68	0,26	6,79	1,16	0,18	7,11	1,18	0,19	5,10	0,21	0,13	4,45	-	0,12	3,40	-	0,10	3,13	-	0,08	2,55	-	0,10	2,33	-	0,06	2,04	-	0,10

G2-KGS-4005																																
n [1/min]	Stroke speed [m/min]		F=50 [kN]						F=30 [kN]						F=20 [kN]						F=10 [kN]						F=5 [kN]					
			2:1			3:1			2:1			3:1			2:1			3:1			2:1			3:1			2:1			3:1		
	2:1	3:1	Nm	HNm	kW	Nm	HNm	kW	Nm	HNm	kW	Nm	HNm	kW	Nm	HNm	kW	Nm	HNm	kW	Nm	HNm	kW	Nm	HNm	kW	Nm	HNm	kW	Nm	HNm	kW
3000	7,50	5,00	28,83	9,64	9,06	19,18	5,44	6,02	18,22	4,86	5,72	12,39	2,38	3,89	12,91	2,47	4,06	8,99	0,86	2,82	7,61	0,09	2,39	5,60	-	1,76	4,95	-	1,56	3,90	-	1,22
2250	5,63	3,75	28,83	9,64	6,79	19,28	5,44	4,54	18,22	4,86	4,29	12,49	2,38	2,94	12,91	2,47	3,04	8,99	0,86	2,12	7,61	0,09	1,79	5,60	-	1,32	4,95	-	1,17	3,90	-	0,92
1500	3,75	2,50	28,83	9,64	4,53	19,28	5,44	3,03	18,22	4,86	2,86	12,49	2,38	1,96	12,91	2,47	2,03	8,99	0,86	1,41	7,61	0,09	1,19	5,60	-	0,88	4,95	-	0,78	3,90	-	0,61
1000	2,50	1,67	28,83	9,64	3,02	19,28	5,44	2,02	18,22	4,86	1,91	12,49	2,38	1,31	12,91	2,47	1,35	8,99	0,86	0,94	7,61	0,09	0,80	5,60	-	0,59	4,95	-	0,52	3,90	-	0,41
750	1,88	1,25	28,83	9,64	2,26	19,28	5,44	1,51	18,22	4,86	1,43	12,49	2,38	0,98	12,91	2,47	1,01	8,99	0,86	0,71	7,61	0,09	0,60	5,60	-	0,44	4,95	-	0,39	3,90	-	0,31
500	1,25	0,83	28,83	9,64	1,51	19,28	5,44	1,01	18,22	4,86	0,95	12,49	2,38	0,65	12,91	2,47	0,68	8,99	0,86	0,47	7,61	0,09	0,40	5,60	-	0,29	4,95	-	0,26	3,90	-	0,20
250	0,63	0,42	28,83	9,64	0,75	19,28	5,44	0,50	18,22	4,86	0,48	12,49	2,38	0,33	12,91	2,47	0,34	8,99	0,86	0,24	7,61	0,09	0,20	5,60	-	0,10	4,95	-	0,13	3,90	-	0,10

G3-KGS-6310																																
n [1/min]	Stroke speed [m/min]		F=90 [kN]						F=75 [kN]						F=50 [kN]						F=25 [kN]						F=10 [kN]					
			2:1			3:1			2:1			3:1			2:1			3:1			2:1			3:1			2:1			3:1		
	2:1	3:1	Nm	HNm	kW	Nm	HNm	kW	Nm	HNm	kW	Nm	HNm	kW	Nm	HNm	kW	Nm	HNm	kW	Nm	HNm	kW	Nm	HNm	kW	Nm	HNm	kW	Nm	HNm	kW
3000	15,00	10,00	99,89	38,57	31,38	67,90	31,47	21,33	83,98	31,41	26,38	57,30	25,51	18,00	57,45	19,47	18,05	39,63	15,57	12,45	30,93	7,54	9,71	21,97	5,64	6,90	15,01	0,37	4,72	11,37	-	3,57
2250	11,25	7,50	99,89	38,57	23,53	67,90	31,47	16,00	83,98	31,41	19,79	57,30	25,51	13,50	57,45	19,47	13,54	39,63	15,57	9,34	30,93	7,54	7,29	21,97	5,64	5,18	15,01	0,37	3,54	11,37	-	2,68
1500	7,50	5,00	99,89	38,57	15,69	67,90	31,47	10,66	83,98	31,41	13,19	57,30	25,51	9,00	57,45	19,47	9,02	39,63	15,57	6,22	30,93	7,54	4,86	21,97	5,64	3,45	15,01	0,37	2,36	11,37	-	1,79
1000	5,00	3,33	99,89	38,57	10,46	67,90	31,47	7,11	83,98	31,41	8,79	57,30	25,51	6,00	57,45	19,47	6,02	39,63	15,57	4,15	30,93	7,54	3,24	21,97	5,64	2,30	15,01	0,37	1,57	11,37	-	1,19
750	3,75	2,50	99,89	38,57	7,84	67,90	31,47	5,33	83,98	31,41	6,60	57,30	25,51	4,50	57,45	19,47	4,51	39,63	15,57	3,11	30,93	7,54	2,43	21,97	5,64	1,73	15,01	0,37	1,18	11,37	-	0,89
500	2,50	1,67	99,89	38,57	5,23	67,90	31,47	3,55	83,98	31,41	4,40	57,30	25,51	3,00	57,45	19,47	3,01	39,63	15,57	2,07	30,93	7,54	1,62	21,97	5,64	1,15	15,01	0,37	0,79	11,37	-	0,60
250	1,25	0,83	99,89	38,57	2,61	67,90	31,47	1,78	83,98	31,41	2,20	57,30	25,51	1,50	57,45	19,47	1,50	39,63	15,57	1,04	30,93	7,54	0,81	21,97	5,64	0,58	15,01	0,37	0,39	11,37	-	0,10

Note: values are valid at an ambient temperature of 20 °C
Tables for other spindle types on request.

Performance table

- F** Axial load
- H** Low ratio (ex.: 2:1)
- L** High ratio (ex.: 3:1)
- Nm** Required drive torque for axial load **F**
- HNm** Required holding torque for axial load **F** (If – no holding torque is required)
- kW** Required driving power in depending on speed

Screw jacks with other screw pitches as in the performance tables:

For screws with higher pitches the power values can be multiplied by the pitch factor.

For example: If a pitch of 10 mm in place of 5 mm use the existing performance data and multiply by the factor of 2, use a factor of 10 if the pitch is 50 mm in place of 5 mm

G1-Tr-24x5																						
n [1/min]	Hubgeschw. [m/min]		F=15 [kN]				F=10 [kN]				F=5 [kN]				F=2,5 [kN]				F=1 [kN]			
			2:1		3:1		2:1		3:1		2:1		3:1		2:1		3:1		2:1		3:1	
	2:1	3:1	Nm	kW	Nm	kW	Nm	kW	Nm	kW	Nm	kW	Nm	kW	Nm	kW	Nm	kW	Nm	kW	Nm	kW
3000	7,50	5,00	15,06	4,73	10,19	3,20	10,64	3,34	7,36	2,31	6,22	1,95	4,53	1,42	4,01	1,26	3,11	0,98	2,68	0,84	2,27	0,71
2250	5,63	3,75	15,06	3,55	10,19	2,40	10,64	2,51	7,36	1,73	6,22	1,47	4,53	1,07	4,01	0,94	3,11	0,73	2,68	0,63	2,27	0,53
1500	3,75	2,50	15,06	2,37	10,19	1,60	10,64	1,67	7,36	1,16	6,22	0,98	4,53	0,71	4,01	0,63	3,11	0,49	2,68	0,42	2,27	0,36
1000	2,50	1,67	15,06	1,58	10,19	1,07	10,64	1,11	7,36	0,77	6,22	0,65	4,53	0,47	4,01	0,42	3,11	0,33	2,68	0,28	2,27	0,24
750	1,88	1,25	15,06	1,18	10,19	0,80	10,64	0,84	7,36	0,58	6,22	0,49	4,53	0,36	4,01	0,31	3,11	0,24	2,68	0,21	2,27	0,18
500	1,25	0,83	15,06	0,79	10,19	0,53	10,64	0,56	7,36	0,39	6,22	0,33	4,53	0,24	4,01	0,21	3,11	0,16	2,68	0,14	2,27	0,12
250	0,63	0,42	15,06	0,39	10,19	0,27	10,64	0,28	7,36	0,19	6,22	0,16	4,53	0,12	4,01	0,10	3,11	0,08	2,68	0,07	2,27	0,06

G2-Tr-40x7																						
n [1/min]	Hubgeschw. [m/min]		F=50 [kN]				F=30 [kN]				F=20 [kN]				F=10 [kN]				F=5 [kN]			
			2:1		3:1		2:1		3:1		2:1		3:1		2:1		3:1		2:1		3:1	
	2:1	3:1	Nm	kW	Nm	kW	Nm	kW	Nm	kW	Nm	kW	Nm	kW	Nm	kW	Nm	kW	Nm	kW	Nm	kW
3000	10,50	7,00	71,93	22,60	48,55	15,25	44,08	13,85	30,01	9,43	30,15	9,47	20,74	6,52	16,23	5,10	11,47	3,60	9,26	2,91	6,84	2,15
2250	7,88	5,25	71,93	16,95	48,55	11,44	44,08	10,38	30,01	7,07	30,15	7,10	20,74	4,89	16,23	3,82	11,47	2,70	9,26	2,18	6,84	1,61
1500	5,25	3,50	71,93	11,30	48,55	7,63	44,08	6,92	30,01	4,71	30,15	4,74	20,74	3,26	16,23	2,55	11,47	1,80	9,26	1,45	6,84	1,07
1000	3,50	2,33	71,93	7,53	48,55	5,08	44,08	4,62	30,01	3,14	30,15	3,16	20,74	2,17	16,23	1,70	11,47	1,20	9,26	0,97	6,84	0,72
750	2,63	1,75	71,93	5,65	48,55	3,81	44,08	3,46	30,01	2,36	30,15	2,37	20,74	1,63	16,23	1,27	11,47	0,90	9,26	0,73	6,84	0,54
500	1,75	1,17	71,93	3,77	48,55	2,54	44,08	2,31	30,01	1,57	30,15	1,58	20,74	1,09	16,23	0,85	11,47	0,60	9,26	0,48	6,84	0,36
250	0,88	0,58	71,93	1,88	48,55	1,27	44,08	1,15	30,01	0,79	30,15	0,79	20,74	0,54	16,23	0,42	11,47	0,10	9,26	0,24	6,84	0,10

G3-Tr-60x9																						
n [1/min]	Hubgeschw. [m/min]		F=90 [kN]				F=75 [kN]				F=50 [kN]				F=25 [kN]				F=10 [kN]			
			2:1		3:1		2:1		3:1		2:1		3:1		2:1		3:1		2:1		3:1	
	2:1	3:1	Nm	kW	Nm	kW	Nm	kW	Nm	kW	Nm	kW	Nm	kW	Nm	kW	Nm	kW	Nm	kW	Nm	kW
3000	13,50	9,00	188,57	59,24	127,08	39,92	157,87	49,59	106,61	33,49	106,71	33,52	72,51	22,78	55,56	17,45	38,40	12,06	24,86	7,81	17,94	5,64
2250	10,13	6,75	188,57	44,43	127,08	29,94	157,87	37,19	106,61	25,12	106,71	25,14	72,51	17,08	55,56	13,09	38,40	9,05	24,86	5,86	17,94	4,23
1500	6,75	4,50	188,57	29,62	127,08	19,96	157,87	24,80	106,61	16,75	106,71	16,76	72,51	11,39	55,56	8,73	38,40	6,03	24,86	3,91	17,94	2,82
1000	4,50	3,00	188,57	19,75	127,08	13,31	157,87	16,53	106,61	11,16	106,71	11,17	72,51	7,59	55,56	5,82	38,40	4,02	24,86	2,60	17,94	1,88
750	3,38	2,25	188,57	14,81	127,08	9,98	157,87	12,40	106,61	8,37	106,71	8,38	72,51	5,69	55,56	4,36	38,40	3,02	24,86	1,95	17,94	1,41
500	2,25	1,50	188,57	9,87	127,08	6,65	157,87	8,27	106,61	5,58	106,71	5,59	72,51	3,80	55,56	2,91	38,40	2,01	24,86	1,30	17,94	0,94
250	1,13	0,75	188,57	4,94	127,08	3,33	157,87	4,13	106,61	2,79	106,71	2,79	72,51	1,90	55,56	1,45	38,40	1,01	24,86	0,65	17,94	0,10

Shaft assemblies & Location of vent valve

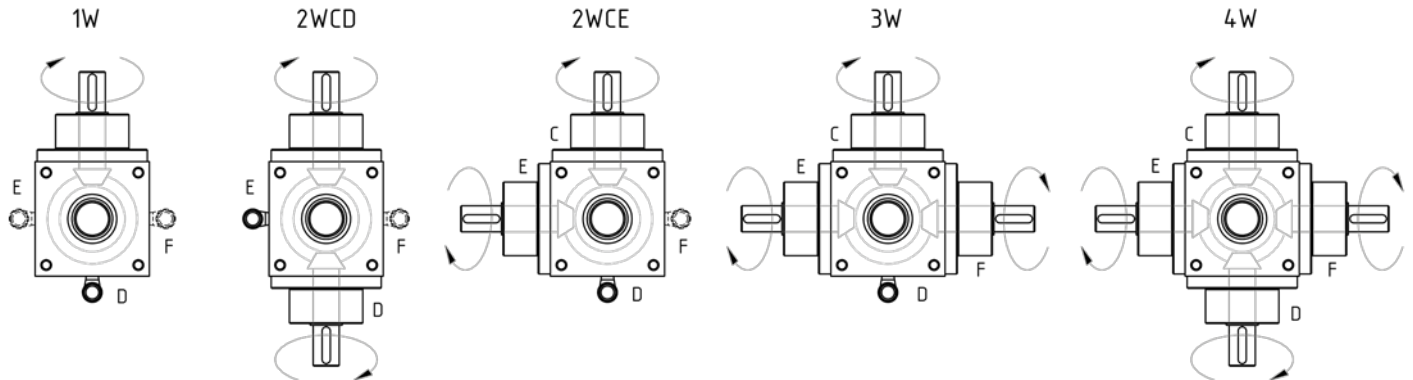

Shaft assemblies

Selection of shaft assemblies and position of oil armatures. The standard positions of the oil armatures is shown in bold. The shaft assemblies and the position of oil armatures can be selected via the product code. Please ensure that change the direction of rotation of the output shaft if you selected more than one shaft.

Location of vent valve

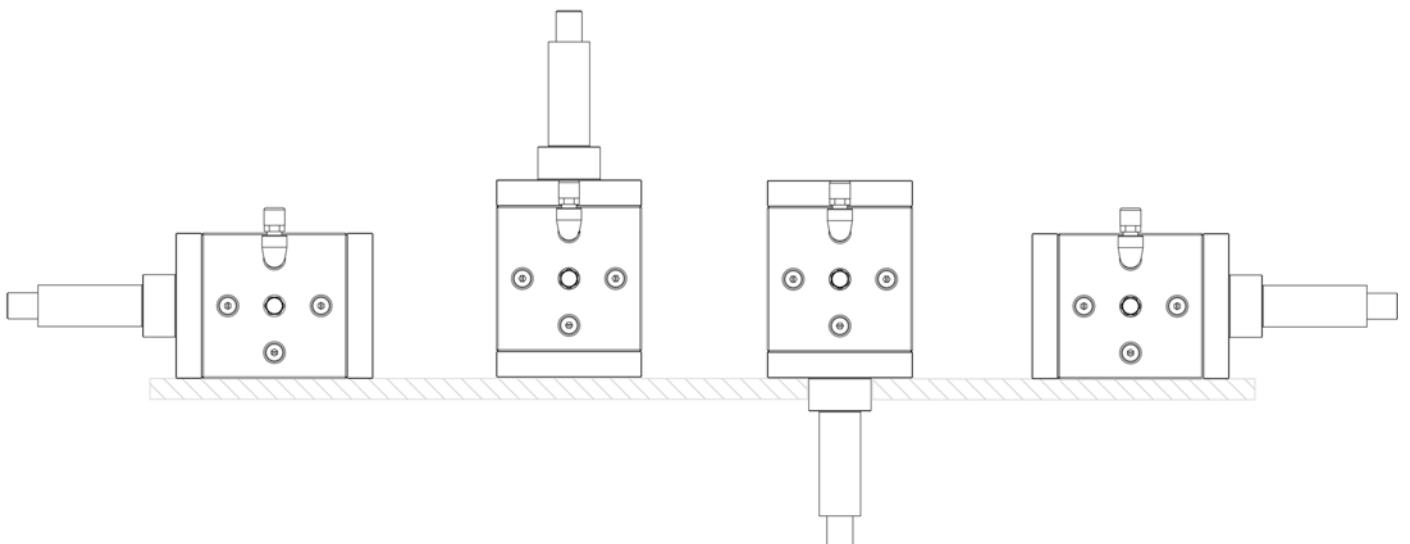

Location of vent valve

Possible positions of appended vent valve on the installation position of the screw jack. At speeds below 1500 1/min the High Speed Screw Jack can be operated without vent valve. Important to ensure in swing operations: Don't assembly the vent valve under the oil level. It consists a risk of oil leakage.

High-speed screw jacks G1

Operating time-Chart G1 at 1500/min
and 20° ambient temperature

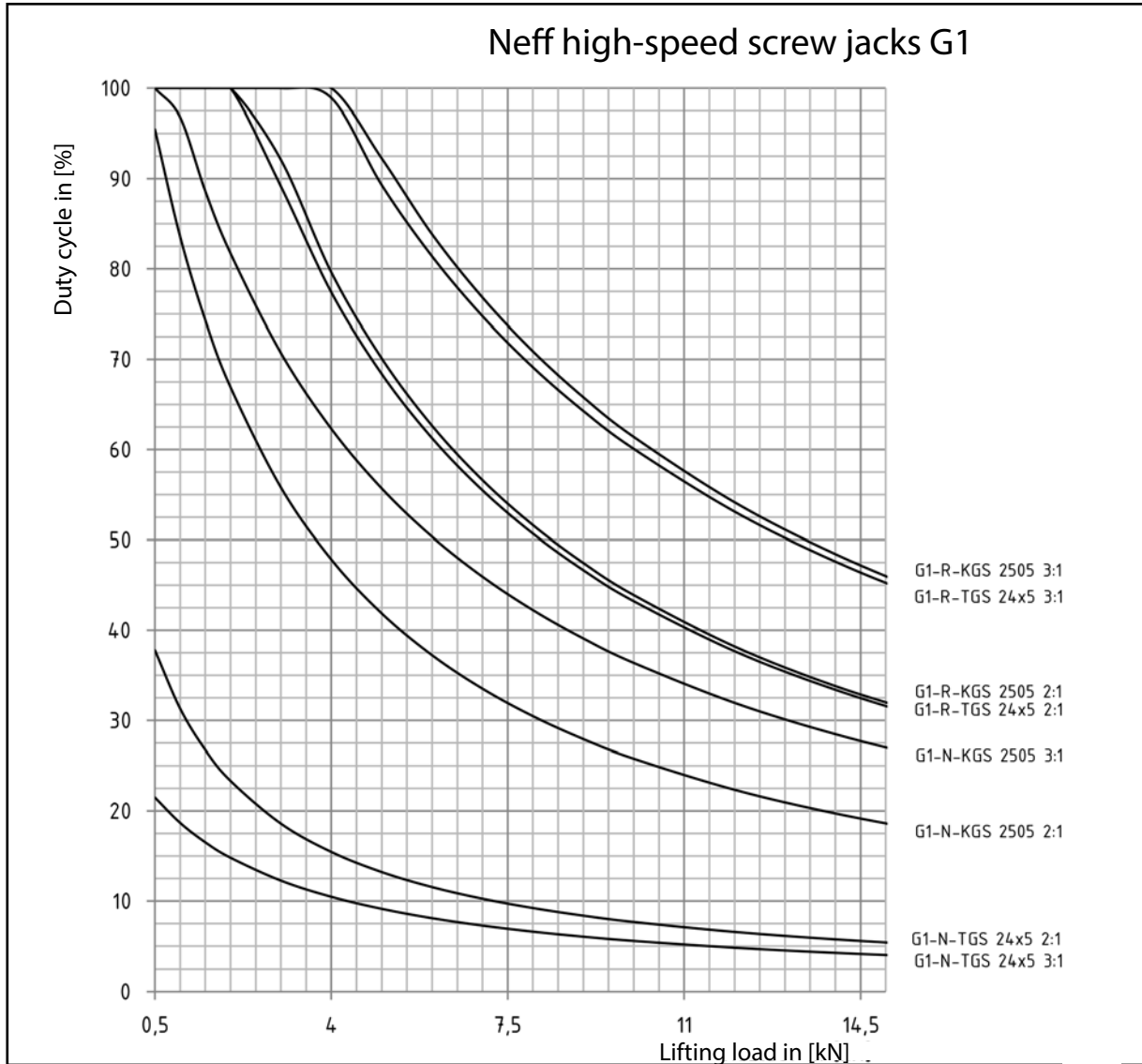

To calculate the Operating time ED_n/h for other speeds, multiply the Operating time in [%] with the speed-factor fn_{neff} :

$$ED_n/h \text{ in } [\%] = ED_h \times fn_{neff}$$

If different speeds determine the average of speed:

$$n_m = n_1 \times q_1 + n_2 \times q_2 + \dots + n_i \times q_i / 100$$

n_1, n_2, \dots = Speed in [1/min] during the clearance

q_1, q_2, \dots = Dues of load duration in [%]

n_m = Average speed in [1/min]

speed	speed factor fn_{neff}
3000	0.5
2500	0.6
2000	0.75
1000	1.5
750	2
500	3
250	6

High-speed screw jacks G2

Operating time-Chart G2 at 1500/min
and 20° ambient temperature

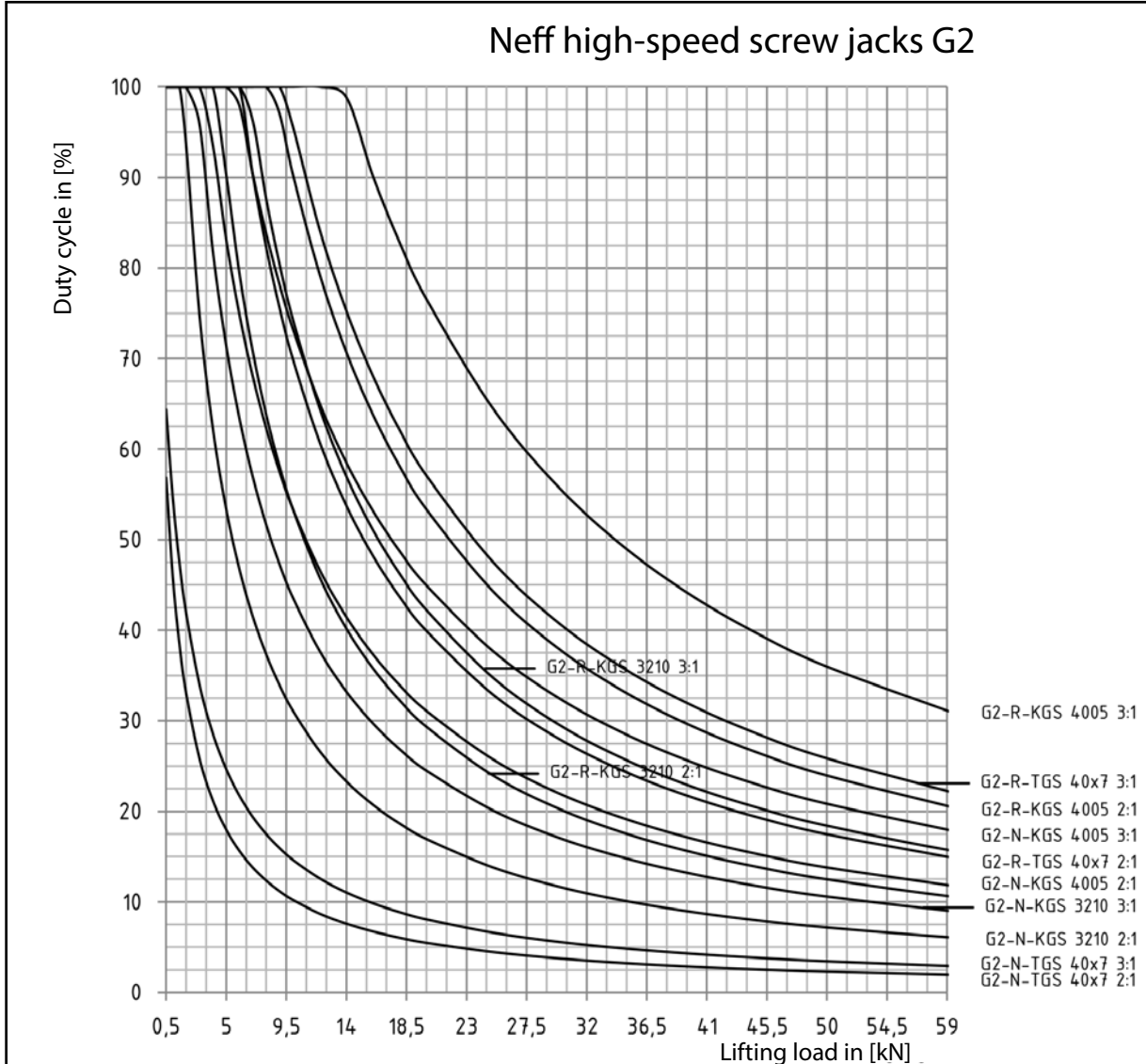

To calculate the Operating time ED_n/h for other speeds, multiply the Operating time in [%] with the speed-factor $f_{n_{neff}}$:

$$ED_n/h \text{ in } [\%] = ED_d/h \times f_{n_{neff}}$$

If different speeds determine the average of speed:

$$n_m = n_1 \times q_1 + n_2 \times q_2 + \dots + n_i \times q_i / 100$$

n_1, n_2, \dots = Speed in [1/min] during the clearance

q_1, q_2, \dots = Dues of load duration in [%]

n_m = Average speed in [1/min]

speed	speed factor $f_{n_{neff}}$
3000	0.5
2500	0.6
2000	0.75
1000	1.5
750	2
500	3
250	6

High-speed screw jacks G3

Operating time-Chart G3 at 1500/min
and 20° ambient temperature

Neff high-speed screw jacks G3

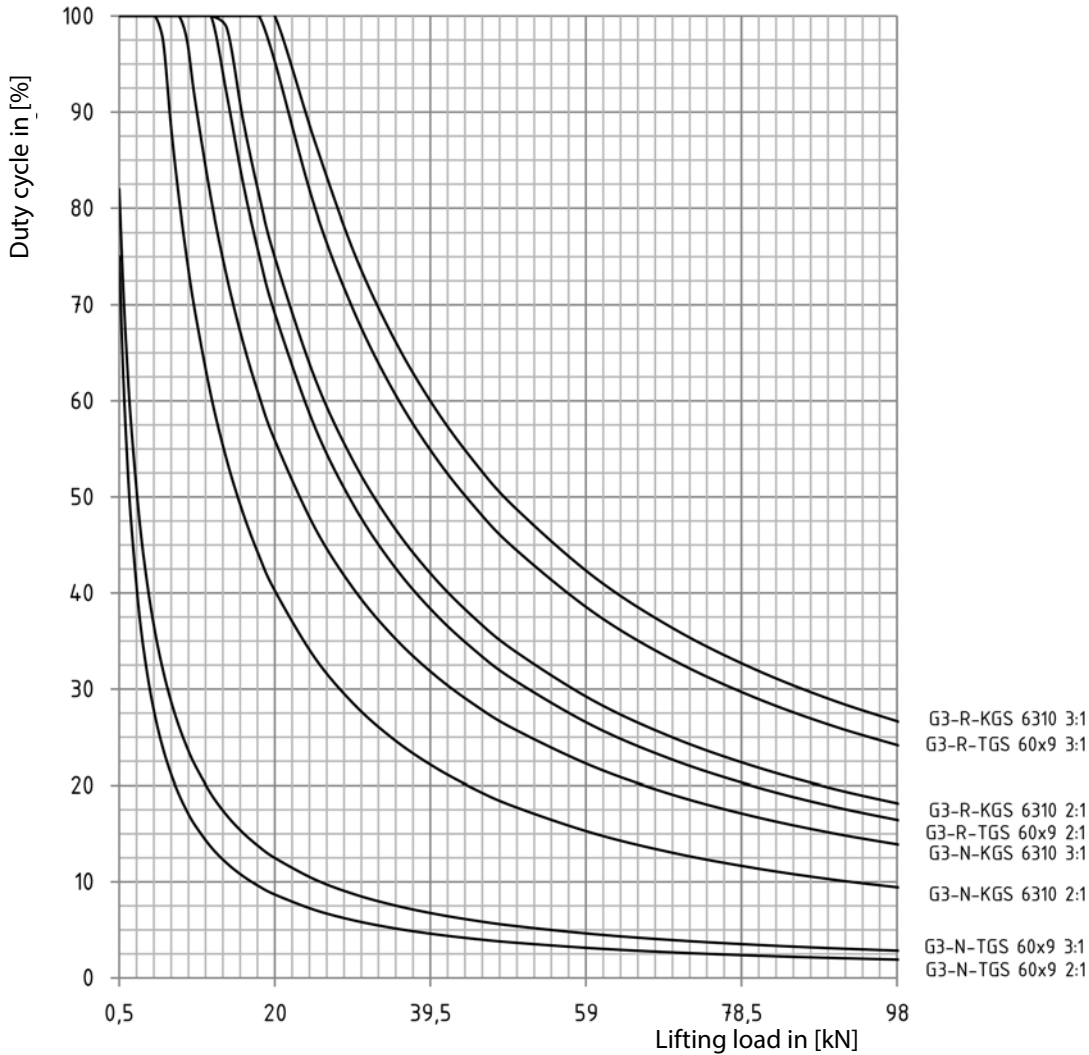

To calculate the Operating time ED_n/h for other speeds, multiply the Operating time in [%] with the speed-factor fn_{neff} :

$$ED_n/h \text{ in } [\%] = ED_q/h \times fn_{neff}$$

If different speeds determine the average of speed:

$$n_m = n_1 \times q_1 + n_2 \times q_2 + \dots + n_i \times q_i / 100$$

n_1, n_2, \dots = Speed in [1/min] during the clearance

q_1, q_2, \dots = Dues of load duration in [%]

n_m = Average speed in [1/min]

speed	speed factor fn_{neff}
3000	0.5
2500	0.6
2000	0.75
1000	1.5
750	2
500	3
250	6

Ordering code

High Speed Screw Jacks

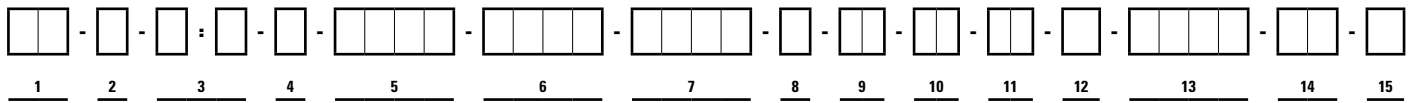

Nr.	Designation	Code	Description
1	Size	G1, G2, G3	
2	Design	N, VK, R	Lifting screw Lifting screw, protected against twisting by square tube Rotating screw
3	Transmission ratio	2:1 3:1	Gearboxes available for all sizes
4	Type of screw	T K	Trapezoidal screw drive Ball screw drive
5	Screw dimension		e.g. 2005 = diameter 20mm, pitch 5mm
6	Stroke in [mm]		Specification of the stroke length
7	Screw extension VL in [mm] for version N/V Usable stroke length NL in [mm] for version R		Screw extension VL, usable stroke length NL e.g. due to block, mounting situation. See product drawings
8	Screw end	M A S Z	Metric threaded stem End with chamfer Custom (according to specification, description or drawing) Centric stem (standard for version R)
9	Attached part for version N/VK/VP	0 BP GA GK HG	None With fastening plate mounted With spherical bearing mounted With fork end mounted With high-performance fork end mounted
	Nut type for version R (other types on request)	F-D F-N D-F N-F EFM-N N-EFM SFF-N N-SFF SFZ-N N-SFZ	Flanged nut according DIN 69051 (flange direction to housing) Flanged nut according Neff-Norm (flange direction to housing) Flanged nut according DIN 69051 (flange direction to screw end) Flanged nut according Neff-Norm (flange direction to screw end) trapezoidal-threaded nut-NEFF-Norm (flange direction to housing) trapezoidal-threaded nut-NEFF-Norm (flange direction to screw end) safety nut - flange side-NEFF-Norm (flange direction to housing) safety nut - flange side-NEFF-Norm (flange direction to screw end) safety nut - centric side-NEFF-Norm (flange direction to housing) safety nut - centric side-NEFF-Norm (flange direction to screw end)
10	Screw cover	0 FB SF	None With bellow With spiral spring cover
11	Anti-unscrewing device	0 AS	None With (installed as standard with ball screw drive)
12	Position of oil fittings	D E F	See product drawings G1-G3 Standard location see description No. 13
13	Shaft arrangement	1W 2WCD 2WCE 3W	1 shaft end (position of oil fittings - side D) 2 shaft ends on side C and D (180°, position of oil fittings - side E) 2 shaft ends on side C and E (90°, position of oil fittings - side D) 3 shaft ends (position of oil fittings - side D)
14	Gear wheel arrangement	RO RU	Gear wheel above (viewed from screw side to gearbox) Gear wheel below (viewed from screw side to gearbox)
15	Requirements	0 1	None According to specification, description or drawing

Worm gear screw jacks

Examples for arrangements and direction of rotation

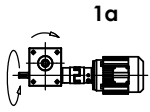

1a

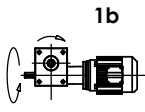

1b

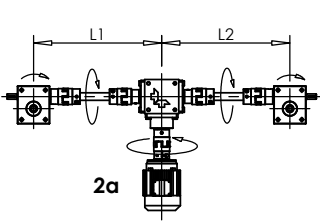

2a

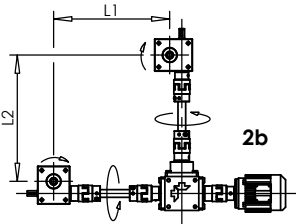

2b

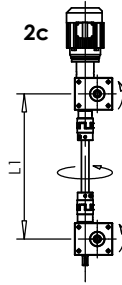

2c

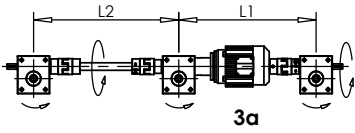

3a

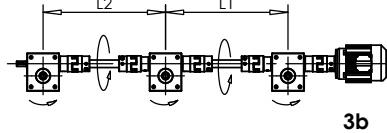

3b

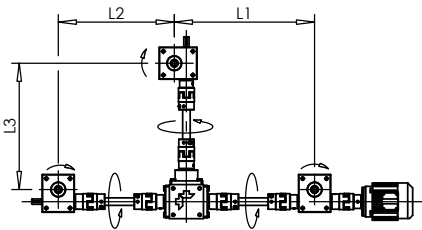

3c

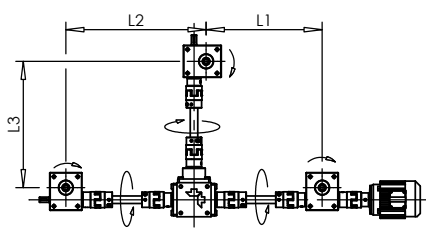

3d

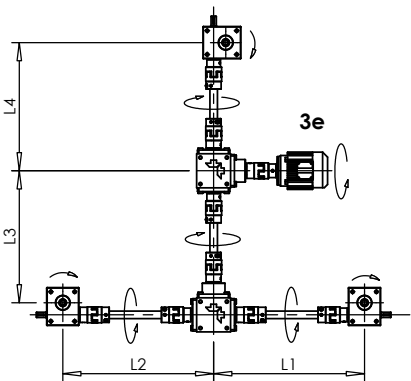

3e

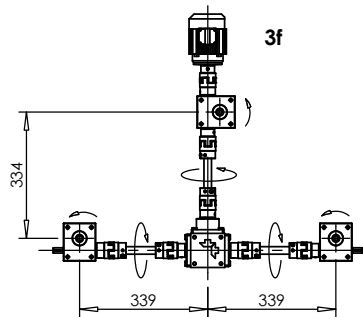

3f

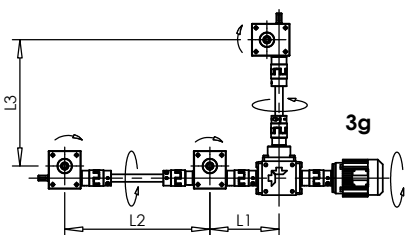

3g

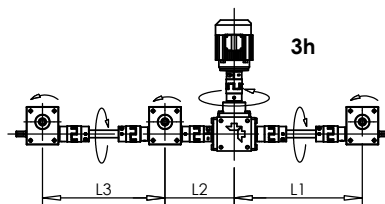

3h

Worm gear screw jacks

Examples for arrangements and direction of rotation

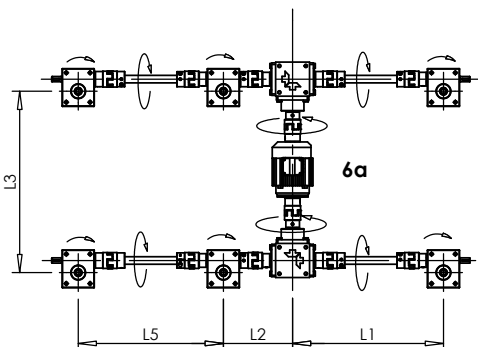
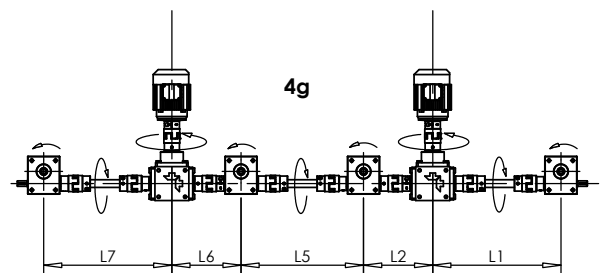
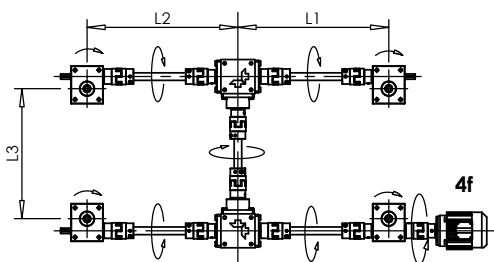
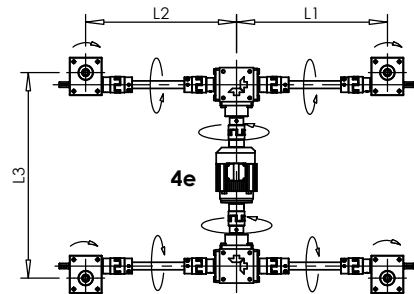
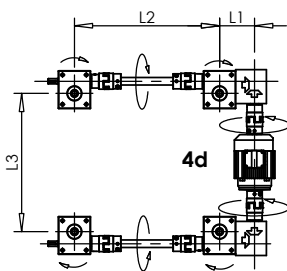
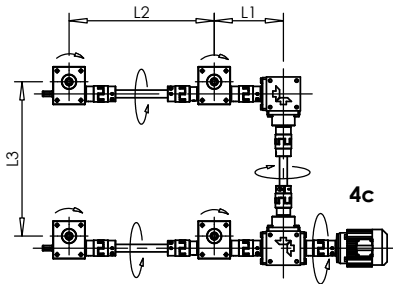
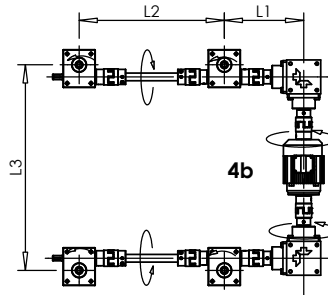
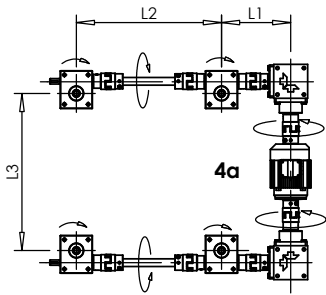

Calculation

Screw Jacks

The general procedure for the design of worm gear screw jacks is as follows:

1. Definition of the speed, the required force and the possible installation position of the worm gear screw jack.
2. Selection of the drive elements (couplings, shafts, bevel gearbox, motors) for the synchronous drive of the individual worm gear screw jacks. The following criteria are decisive here:
 - Lowest possible load on the individual transmission elements. In particular, the introduction of the total drive torque via the toothing of a bevel gearbox is to be avoided
 - Lowest possible number of transmission elements and short connecting shafts.
 - Device for the protection of the unit by torque-limiting coupling.

Selection of a worm gear screw jack and the associated drive

Axial load $F=kN$

Critical buckling force? see pages 78-80

Speed $v = m/min$ (only version R)

Critical speed? see pages 78-80

Duty cycle? DC = % in 1hr

see pages 62-64; 70-72

Select gearbox size

Calculate or look up required drive torque

see page 81

Check permissible drive torque

Check lateral forces acting on the spindle as well as axial and radial forces acting on drive shafts

(avoid lateral forces on spindle = guide)

Calculate necessary drive power in KW (observe breakaway torque)

see page 77

Calculation

Screw Jacks

Forces and torques on the worm gear screw jack

Note: Forces and torques can only be estimated using simplifying assumptions; friction coefficients of sliding pairings and thus their temperature rise and service life are functions of load, speed, temperature and lubrication conditions; critical speeds and buckling lengths depend on the rigidity and mass of the clamping and the machine frame etc.

F_{eff}	=	Axial force on the lifting spindle
F_S	=	Resultant of all lateral forces acting on the lifting spindle
M	=	Torque of the lifting spindle or nut (omitted in version V)
V_H	=	Stroke speed
F_{ax}	=	Axial force on the drive shaft
F_r	=	Radial force on the drive shaft
M_T	=	Drive torque
n_T	=	Drive speed
P	=	Pitch of the spindle
i	=	Transmission ratio
η	=	Efficiency
M_0	=	Idling torque (p. 28 (Nm))

$$F_{\text{eff}} = \frac{M_T - M_0}{\frac{P}{i}} \cdot 2 \cdot \pi \cdot \eta$$

Drive power

$$P_a = \frac{M_d \cdot n}{9550}$$

M_d	Required drive torque [Nm]
n	Spindle speed [rpm]
P_a	Required drive power [KW]

Calculation

Screw Jacks

Theoretically critical buckling force, worm gear screw jack M/J, high-speed screw jack G1-G3 with ball screw

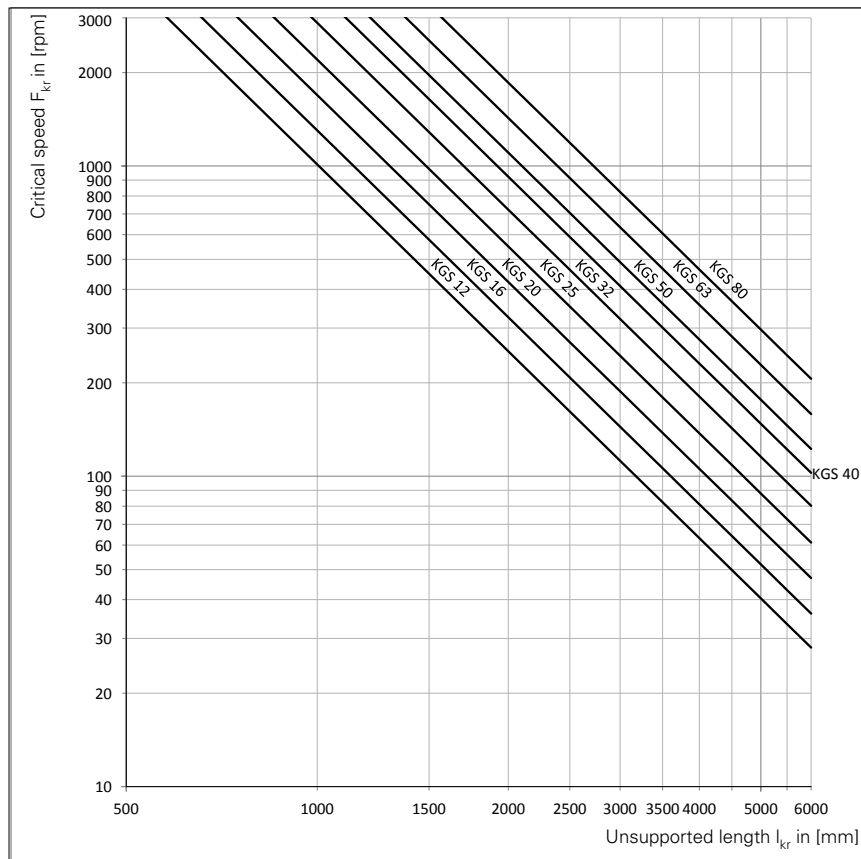
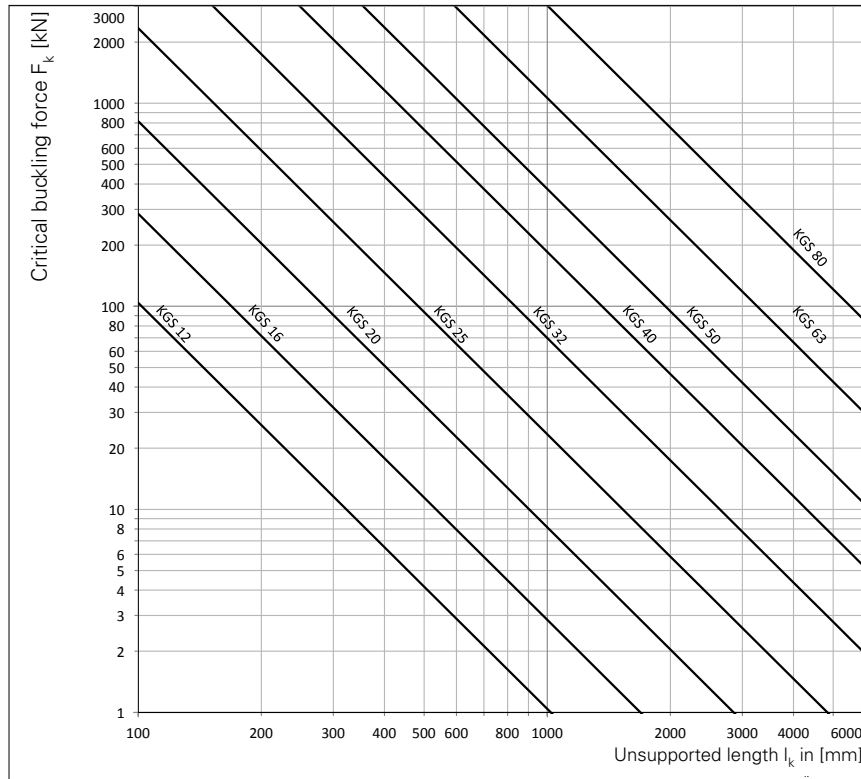

Calculation

Screw Jacks

Theoretically critical buckling force, worm gear screw jack M/J, high-speed screw jack G1-G3 with trapezoidal-threaded spindle

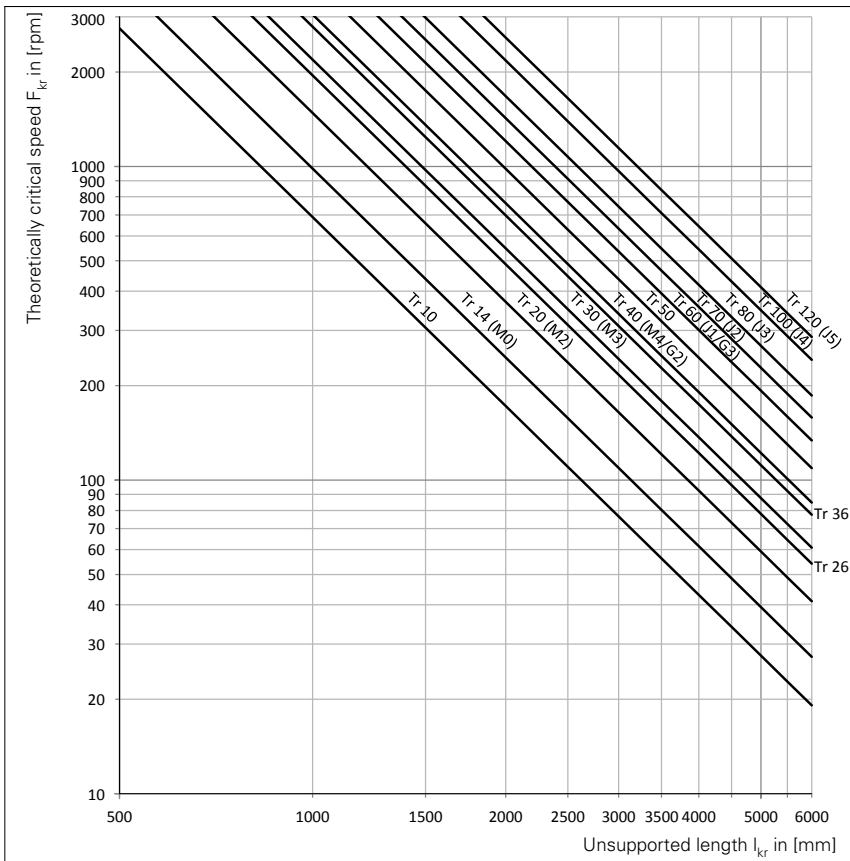
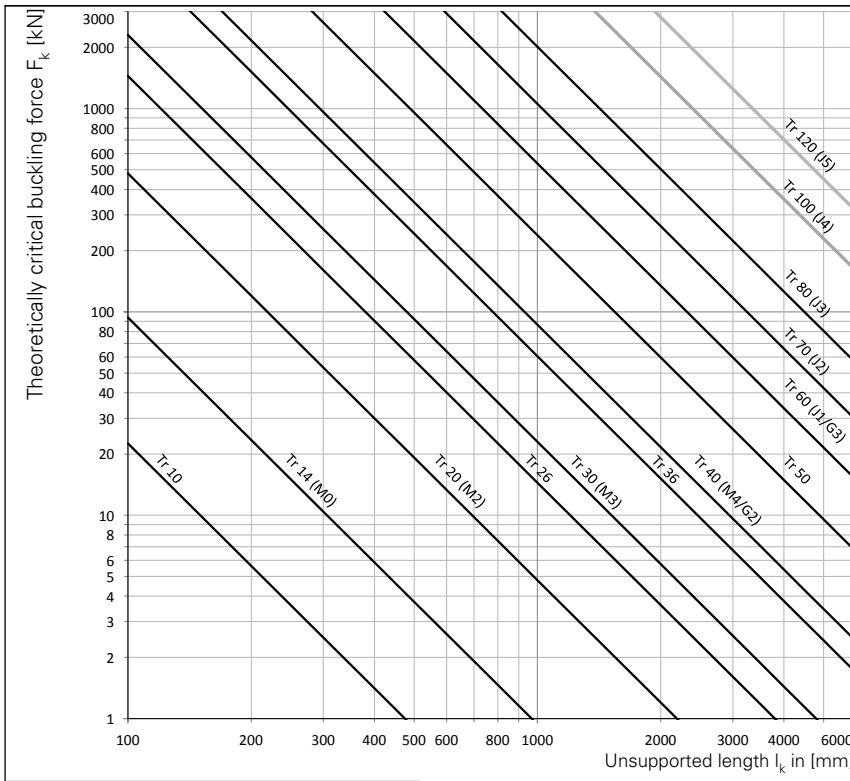

Calculation

Screw Jacks

Critical buckling force

With slim lifting spindles there is a risk of lateral buckling under compressive loads.

The safety factors applying to the system must be considered before determining the permissible compressive force on the spindle.

Types of bearing

Typical values for the correction factor f_k according to the classic installation cases for standard spindle bearings.

Neff bearing case I

Fixed bearing-loose end, correction factor $f_k=0.25 / f_{kr}=0.43$

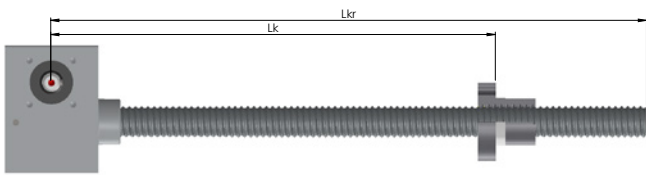

Neff bearing case II

Movable bearing-movable bearing, correction factor $f_k=1 / f_{kr}=1.21$

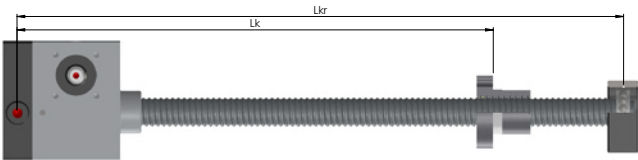

Neff bearing case III

Fixed bearing-movable bearing, correction factor $f_k=2.05 / f_{kr}=1.89$

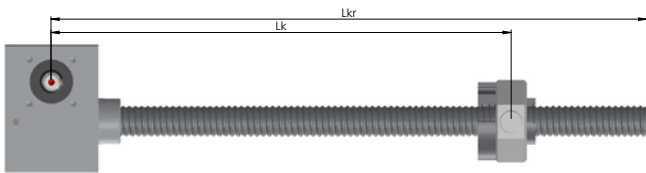

Neff bearing case IV

Fixed bearing-fixed bearing, correction factor $f_k=4 / f_{kr}=2.74$

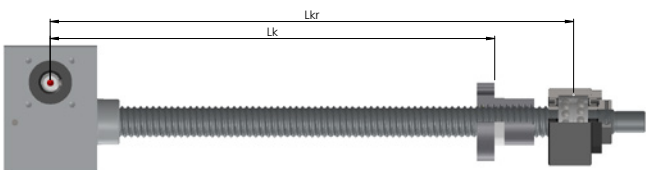

Critical buckling force, worm gear screw jack M/J, high-speed screw jack G1-G3 with ball screw/trapezoidal-threaded spindle

Theoretical critical buckling force in [kN]:

$$F_k = \left(\frac{d_2^4}{L_k^2} \cdot 10^5 \right) : 1000$$

Maximum permissible axial force in:

$$F_{zul} = F_k \cdot f_k \cdot \frac{1}{S_f}$$

F_{zul}	Maximum permissible axial force [kN]
F_k	Theoretical critical buckling force [kN]
f_k	Correction factor that takes into account the type of spindle bearing
d_2	Core diameter of the spindle [mm]
L_k	Unsupported length on which the force acts on the spindle [mm]
S_f	Safety factor (specified by the user)

Caution!

The operating force must not exceed 80% of the maximum permissible axial force!

Critical buckling force, worm gear screw jack M/J, high-speed screw jack G1-G3 with ball screw

Theoretically critical speed in [1/min]

$$F_{kr} = \left(\frac{d_2^2}{L_{kr}^2} \cdot 10^8 \right)$$

n_{zul}	Maximum permissible spindle speed [rpm]
n_{kr}	Theoretically critical spindle speed [rpm] that leads to resonant vibrations
f_{kr}	Correction factor that takes into account the type of spindle bearing
d_2	Core diameter of the spindle [mm]
L_{kr}	unsupported spindle length [mm]

Caution!

The operating force must not exceed 80% of the maximum permissible axial force!

Maximum permissible speed in [rpm]

$$f_{kr} = F_{kr} \cdot f_k \cdot 0.8$$

Drive sizing

Required drive torque

Required drive torque of a worm gear screw jack

The required drive torque of a worm gear screw jack is governed by the axial load acting on the jack screw, the transmission ratio and the efficiency. It should be noted that the breakaway torque may be considerably higher than the torque required for continuous running. This applies in particular to worm gear screw jacks with low efficiency after a long standstill period. The acceleration torque should be checked if necessary in cases with large spindle pitches and very short start-up times.

$$M_T = \frac{F_{\text{eff}}}{2 \cdot \pi \cdot \eta} \cdot \frac{p}{i} + M_0$$

Note:

The required drive torque does not represent a criterion for the selection of the motor. The user must decide here, what power he considers necessary!

- M_T is the required drive torque of the worm gear screw drive at the worm shaft [Nm].
- F_{eff} is the actual force acting on the jack screw [kN].
- η is the efficiency of the worm gear screw jack in decimal notation e.g. 0.32 instead of 32 %. η is an average value determined by measurement.
- $\frac{p}{i}$ is the transmission ratio of the worm gear screw drive in mm stroke length per revolution of the worm shaft.
- M_0 is the idle torque of the worm gear screw drive [Nm]. M_0 is determined by measurements undertaken after a brief running in period with liquid grease lubrication at room temperature. It represents an average value which may vary to a greater or lesser extent, depending on the running-in state, lubricant and temperature. For values, see table.

Required drive torque for a worm gear screw jack system

The required drive torque for a worm gear screw jack system is governed by the drive torque values for the individual jacks with allowance for the static and dynamic frictional losses in transmission components (coupling, universal joint shafts, pillow blocks, angle gear boxes, etc.). It is useful to draw a diagram illustrating the flow of forces.

$$M_{\text{drive motor}} = M_{T \text{ SHG1}} \cdot \frac{1}{\eta_{V1}} + M_{T \text{ SHG2}} + M_{T \text{ SHG3}} \cdot \frac{1}{\eta_{V2}} \cdot \frac{1}{\eta_K}$$

- $M_{T \text{ SHG1}}$ is the required drive torque for the worm gear screw jack SHG 1. It should be noted that the start-up torque (breakaway torque and possibly acceleration torque) may be considerably higher than the torque required for continuous running. This applies in particular to worm gear screw jacks with low efficiency after a long standstill period.
- η_{V1} (V1) includes the static and dynamic frictional losses in the pedestal bearings and couplings.
- η_{V2} is the efficiency of connecting shaft V2.
- η_V = 0.75...0.95 depending on the length of the shaft and number of pedestal bearings.
- η_K is the efficiency of the bevel gearbox (only for the force flow via the toothing, i.e. between connecting shaft V2 and the drive motor).
- $\eta_K = 0.90$

Maximum drive power in KW:

	M 0	M 1	M 2	M 3	M 4	M 5	J 1	J 2	J 3	J 4	J 5
Trans. H (trapezoidal)	0.18	0.3	0.55	1.18	2.3	4.7	6.5	8.4	10.9	14.7	19
Trans. L (trapezoidal)	0.12	0.19	0.35	0.75	1.4	3	4.2	5.4	7.3	9.3	12
Ball screw	0.18	0.3	0.56	0.95	1.7/3.2	5.9	–	–	13.9	–	–

These values do not represent a criterion for the choice of drive motor. This must be selected instead according to torque, speed and operating conditions.

Drive sizing

Required drive torque

Maximum drive torque

If the worm gear screw jack jams as a result of the spindle coming into contact with an obstacle, the tothing can still absorb the following maximum torque values M_T at the drive shaft.

In the case of screw jacks connected in series, the screw jack closest to the drive can absorb this torque at its drive shaft.

Size	M_{Tmax} [Nm]
M 0	1.5
M 1	3.4
M 2	7.1
M 3	18
M 4	38
M 5	93
J 1	148
J 2	178
J 3	240
J 4	340
J 5	570

Acceleration values

Three-phase asynchronous motor, 4-pole:

- Approx. 0.5 m/s² (when switched on directly).

Servo motor:

- Max. 5 m/s² (limited by max. drive torque).
When using screw jacks in conjunction with servo motors, note that:
- Greater masses are moved compared with linear axes.
- Predominantly constant speeds with different speeds of rotation are used.
- Use is often in the area of the adjustment/positioning of equipment.
- Positions are travelled to with relatively short duty cycles and high acceleration values are therefore less frequently called for.
- High acceleration values have only a negligible effect on the overall stroke time, because of the low stroke speeds.

Forces and torque values acting on the drive shaft

If worm gear screw jacks are not driven free of lateral forces by means of a coupling connected to the motor shaft, but are instead driven by chains or belts, care must be taken to ensure that the radial force acting on the drive shaft does not exceed the limit values (see below).

In the worst case due to deflection caused by the radial force F_R the worm shaft will lift off of the worm gear wheel. This must be avoided, since it impairs the engagement between worm shaft and worm gear wheel and leads to higher wear.

Size	F_{Rmax} [kN]
M 0	0.07
M 1	0.1
M 2	0.2
M 3	0.3
M 4	0.5
M 5	0.8
J 1	0.8
J 2	1.3
J 3	1.3
J 4	2.1
J 5	3.1

Selection of drive motor

A suitable drive motor can be selected if the required drive torque and drive speed are known. After selecting a drive motor, check that it will not overload any of the worm gear screw jacks or transmission components. This risk may occur, in particular, in installations with several screw jacks if they are loaded unevenly. It will generally be necessary to install limit switches or torque-limiting couplings to protect the installation against impacting against end positions and obstacles.

Forces and torque values on the motor shaft

Toothed-belt or chain drives may exert considerable radial forces on the motor shaft if a very small sprocket is used. Please consult the motor manufacturer in cases of doubt.

Selection of a bevel gearbox

Selection of a bevel gearbox is governed by the following factors:

- Drive torque
- Drive speed (see dimensional tables)
- Duty cycle and drive power
- Forces and torques acting on the ends of the shaft (please consult us in cases of doubt).

Required drive speed

The required drive speed is governed by the desired stroke speed, the transmission ratio of the screw jack and the transmission ratio of the other transmission components. A particular stroke speed can normally be achieved in several ways. Correct selection depends on the following criteria:

- Favourable efficiency.
- Minimum load on transmission components in order to achieve compact, low-cost design.
- Avoiding critical speeds for screw jacks and connecting shafts.

Screw jack nut torques

The nut torque (M) of the screw jack is the torque that the screw jack exerts on the mounting plate (all N versions except V), or the torque that the screw applies to the travelling nut (R Version). It is not to be confused with the drive torque (M_T) of the screw jack gears on the worm shaft.

$$M \text{ [Nm]} = F_{\text{eff}} \text{ [kN]} \cdot f_M \text{ (applicable in the areas of moderate and high loads)}$$

M is the screw jack nut torque [Nm] for the "Lift under Load" movement.

F_{eff} is the actual supported axial force [kN].

f_M is a conversion factor that accounts for spindle geometry and friction. The value is applicable under normal lubrication conditions. The higher value applies to dry friction and static friction. In the case of ball screw drives, f_M is practically constant.

Size	f_M (Trapezoidal screw)	f_M (Ball screw)
M 0	1.4	1.2
M 1	1.6	1.6
M 2	1.8	1.6
M 3	2.7	1.6
M 4	3.4	1.6/3.2
M 5	4.6	3.2
J 1	5.5	–
J 2	6.4	–
J 3	7.2	3.2
J 4	8.0	–
J 5	10.6	–

Accessories Worm gear screw- jacks

Mounting feet BL-L

Supplied loose with mounting bolts for jack. Burnished.
M 1 + 2 with version N-KGT not on side F. Standard: side E.

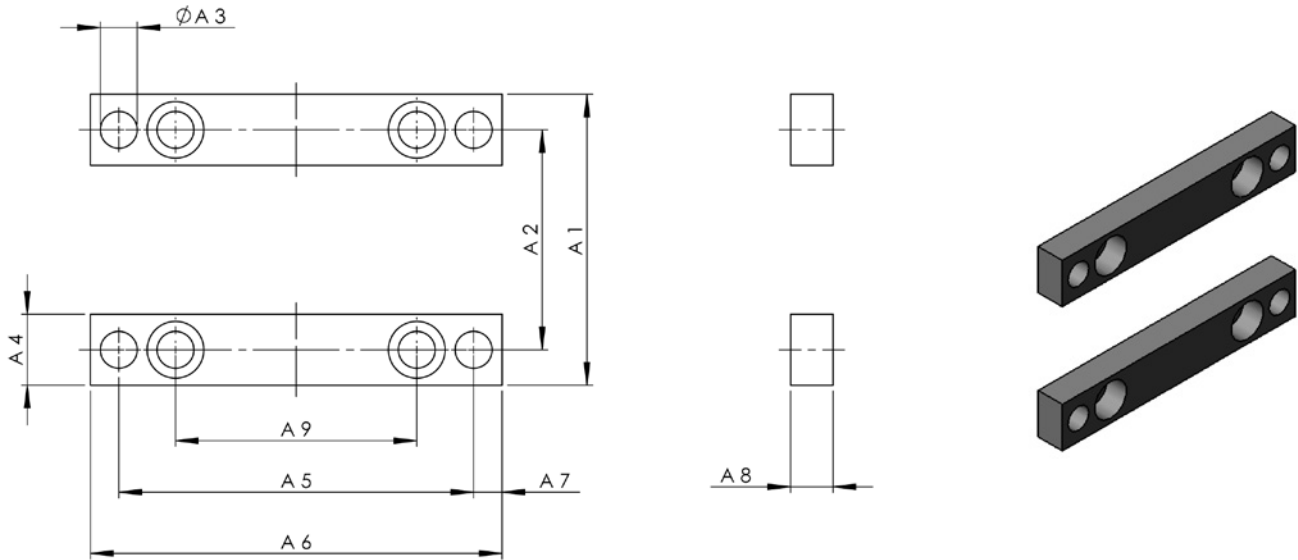

Size	Dimensions [mm]									Weight [kg]
	A ₁	A ₂	A ₃	A ₄	A ₅	A ₆	A ₇	A ₈	A ₉	
BL - L M 0	50	38	6.5	12	75	90	7.5	10	48	0.1
BL - L M 1	72	52	8.5	20	100	120	10	10	60	0.3
BL - L M 2	83	63	8.5	20	120	140	10	10	78	0.4
BL - L M 3	105	81	11	24	150	170	10	12	106	0.8
BL - L M 4	145	115	13.5	30	204	230	13	16	150	1.7
BL - L M 5	171	131	22	40	236	270	17	25	166	3.9
BL - L J 1	205	155	26	50	250	290	20	30	170	5.8
BL - L J 2	235	170	32	65	290	340	25	40	190	10
BL - L J 3	235	170	32	65	290	340	25	40	190	10
BL - L J 4	270	190	39	80	350	410	30	50	230	20.8
BL - L J 5	330	230	45	100	430	500	35	60	290	34.4

Universal joint adapter

Universal joint adapter KA-ZL-CD

Supplied loose with mounting bolts for jack.

Burnished.

Standard: side E. Side F please specify.

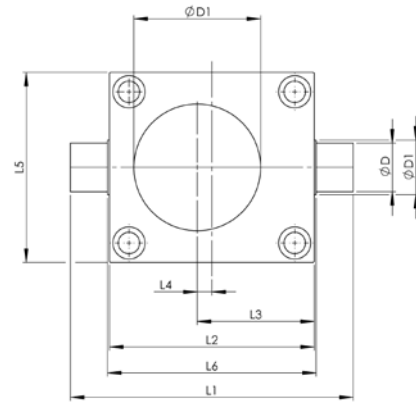
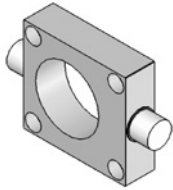

Lengthwise	L ₁	L ₂	L ₃	L ₄	L ₅	L ₆	Ø D ₁₈	ØD ₁	Ø D ₂	B
M 0	80	60	38	8	50	64	10	30	13	15
M 1	110	80	49	9	72	84	15	35	18	20
M 2	140	100	60	10	85	104	20	45	23	25
M 3	170	130	76	11	105	134	25	55	28	30
M 4	240	180	102	12	145	184	35	70	38	40
M 5	270	200	117	17	165	204	45	95	48	50
J 1	290	210	120	15	195	214	50	100	56	60
J 2	330	240	140	20	220	244	70	115	76	80
J 3	330	240	140	20	220	244	70	130	76	80
J 4	410	290	165	20	250	294	80	155	88	90
J 5	520	360	210	30	300	364	90	185	96	100

Universal joint adapter KA-ZQ-AB

Supplied loose with mounting bolts for jack.

Burnished.

Standard: side E. Side F please specify.

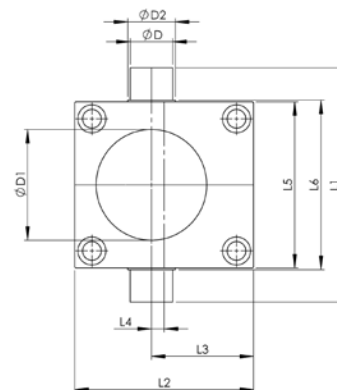
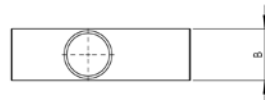
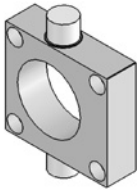

Quer	L ₁	L ₂	L ₃	L ₄	L ₅	L ₆	Ø D ₁₈	ØD ₁	Ø D ₂	B
M 0	70	60	38	8	50	54	10	30	13	15
M 1	102	80	49	9	72	76	15	35	18	20
M 2	125	100	60	10	85	89	20	45	23	25
M 3	145	130	76	11	105	109	25	55	28	30
M 4	205	180	102	12	145	149	35	70	38	40
M 5	235	200	117	17	165	169	45	95	48	50
J 1	289	210	120	15	195	199	50	100	56	60
J 2	313	240	140	20	220	224	70	115	76	80
J 3	313	240	140	20	220	224	70	130	76	80
J 4	370	290	165	20	250	254	80	155	88	90
J 5	460	360	210	30	300	304	90	185	96	100

Universal joint bearing

Universal joint bearing flange

for mounting a universal joint adaptor or a universal joint bearing

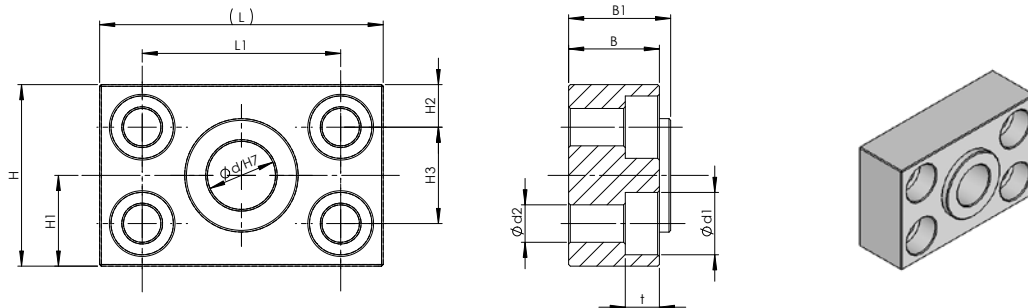

Size	ϕd^{H7}	ϕd_1	ϕd_2	t	B	B_1	H	H_1	H_2	H_3	L	L_1
KLF-0	10	11	6.6	6.8	16	18	32	16	7.5	17	50	35
KLF-1	15	15	9	9	20	22	36	18	9	18	65	45
KLF-2	20	15	9	9	20	23	40	20	10	20	70	50
KLF-3	25	18	11	11	20	22.5	54	27	12	30	80	58
KLF-4	35	20	13.5	13	30	35	70	35	15	40	100	70
KLF-5	45	33	22	21.5	40	43	80	40	20	40	140	100
KLF-200	70	48	33	32	50	58	125	62.5	30	65	220	160
KLF-300	80	57	39	38	62	70	144	72	34	76	245	180
KLF-400	80	57	39	38	62	70	144	72	34	76	245	180
KLF-500	90	66	45	44	80	90	160	80	40	80	28	200

Universal joint bearing pedestal

for mounting a universal joint adaptor or a universal joint bearing.

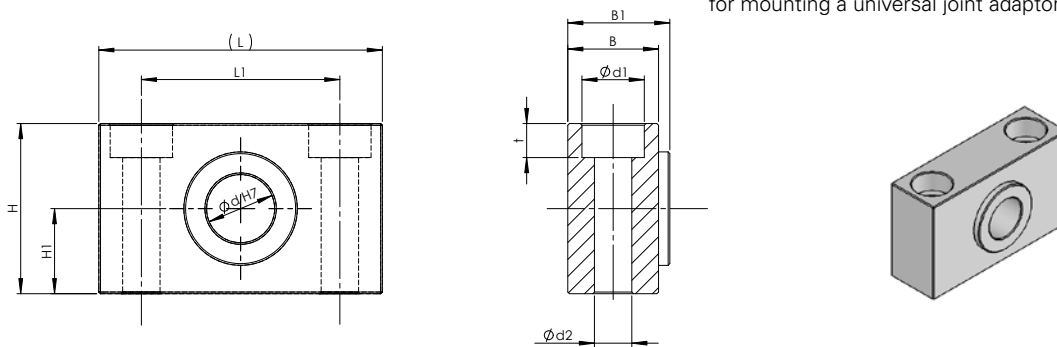

Size	ϕd^{H7}	ϕd_1	ϕd_2	t	B	B_1	H	H_1	L	L_1
KLB-0	10	11	6.6	6.8	16	18	30	15	50	35
KLB-1	15	15	9	9	20	22	34	17	65	45
KLB-2	20	15	9	9	20	23	38	19	70	50
KLB-3	25	18	11	11	20	22.5	54	27	80	58
KLB-4	35	20	13.5	13	30	35	70	35	100	70
KLB-5	45	33	22	21.5	40	43	80	40	140	100
KLB-100	50	40	26	24.8	50	53	100	50	180	130
KLB-200	70	48	33	32	63	71	124	62	220	160
KLB-300	70	57	39	38	63	71	144	72	245	180
KLB-400	80	57	39	38	63	71	144	72	245	180
KLB-500	90	66	45	44	80	90	160	80	280	200

Attachments

Top plate BP

Screwed onto the mounting thread of the screw jack and protected against rotation.

Standard: Bore pattern BP symmetrically to SHG housing.

Note: Please specify alignment in case of version V.

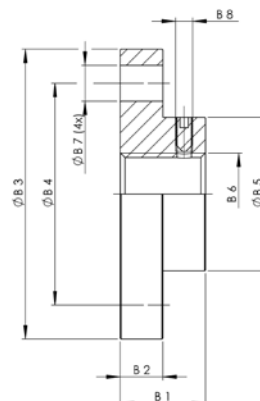
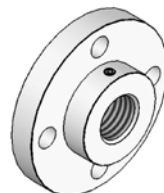

Size	Dimensions [mm]								Weight [kg]
	B ₁	B ₂	∅ B ₃	B ₄	B ₅	B ₆	B ₇ x4	B ₈	
BP M 0	16	6	50	40	26	M8	7	M4	0.1
BP M 1	20	7	65	48	30	M12	9	M5	0.2
BP M 2	21	8	80	60	38.7	M14	11	M6	0.3
BP M 3	23	10	90	67	46	M20	11	M8	0.6
BP M 4	30	15	110	85	60	M30	13	M8	1.2
BP M 5	50	20	150	117	85	M36	17	M10	4.8
BP J 1	50	25	170	130	90	M48 x 2	21	M10	5
BP J 2	60	30	200	155	105	M56 x 2	25	M12	7.7
BP J 3	60	30	220	170	120	M64 x 3	25	M12	9.8
BP J 4	80	40	260	205	145	M72 x 3	32	M12	18.4
BP J 5	120	40	310	240	170	M100 x 3	38	M12	29.6

Fork end GK

Screwed onto the mounting thread of the screw jack and protected against rotation. Supplied with split pins and collar pins.

Standard: Collar pin mounted parallel to the drive shaft.

Note: Please specify alignment in case of version V.

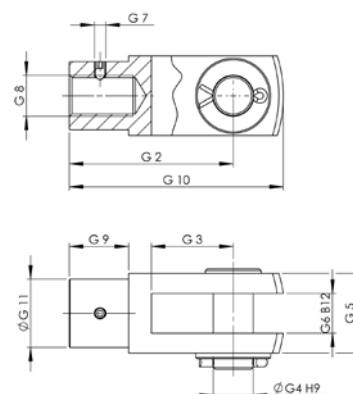
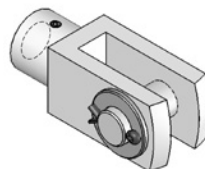

Size	Dimensions [mm]										Weight [kg]
	G ₂	G ₃	G ₄ H9	G ₅ k	G ₆ B12	G ₇	G ₈	G ₉	G ₁₀	G ₁₁	
GK M 0	32	16	8	16	8	M4	M8	12	42	14	0.04
GK M 1	48	24	12	24	12	M5	M12	18	62	20	0.15
GK M 2	56	28	14	28	14	M6	M14	22	72	24.5	0.2
GK M 3	80	40	20	40	20	M8	M20	30	105	34	0.8
GK M 4	120	60	30	60	30	M8	M30	43	160	52	2.5
GK M 5	144	72	35	70	35	M10	M36	54	188	60	3.8

Attachments

Spherical bearing GA

Screwed onto the mounting thread of the screw jack and protected against rotation.

Standard: Position of the transverse bore parallel to drive shaft.

Note: Please specify alignment in case of version V.

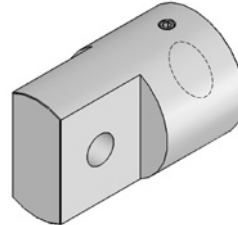
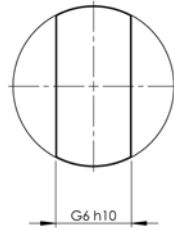
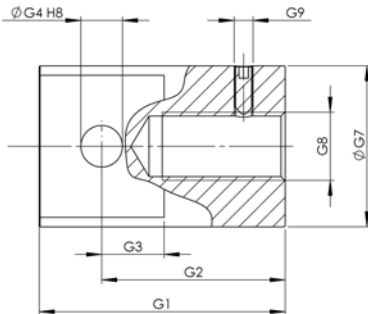

Size	Dimensions [mm]								Weight [kg]
	G ₁	G ₂	G ₃	G ₄ H8	G ₆ H10	G ₇	G ₈	G ₉	
GA M 0	40	30	10	8	12	25	M8	M4	0.1
GA M 1	55	40	15	10	15	30	M12	M5	0.2
GA M 2	63	45	18	12	20	39	M14	M6	0.3
GA M 3	78	53	20	16	30	45	M20	M8	0.6
GA M 4	100	70	30	20	35	60	M30	M8	1.2
GA M 5	130	97	33	22	40	85	M36	M10	2.5
GA J 1	120	75	45	40	60	90	M48 x 2	M10	4.8
GA J 2	130	90	50	50	70	105	M56 x 2	M12	4.8
GA J 3	155	105	60	60	80	120	M64 x 3	M12	8.0
GA J 4	220	135	85	80	110	145	M72 x 3	M12	22.5
GA J 5	300	200	100	90	120	170	M100 x 3	M12	31.5

High-performance joint head HG

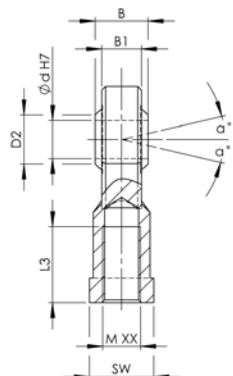
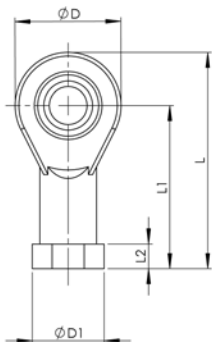

Dimension	Ød ^{H7}	M	B	B1	D	D1	D2	L	L1	L2	L3	SW	Co / (KN)	Angle (°)	Weight
HG-0	10	M 10	14	10.5	28	19	12.9	57	43	6.5	20	17	17.65	13	0.076
HG-1	12	M 12	16	12	32	22	15.4	66	50	6.5	22	19	20.6	13	0.115
HG-2	14	M 14	19	13.5	36	25	16.8	75	57	8	25	22	29.4	15	0.17
HG-3	20	M 20x1.5	25	18	50	34	24.3	102	77	10	33	32	49.1	15	0.415
HG-4	30	M 30x2	37	25	70	50	34.8	145	110	15	51	41	99.1	15	1.13
HG-5	35	M 36x2	43	28	80	58	37.7	165	125	17	65	50	125	15	1.6
HG-6	70	M 56x4	49	42	160	98	92	280	200	20	80	85	630	6	8.4

3-phase motors M

3-phase 4-pole motors (1500 rpm) in totally enclosed fan-cooled designs in accordance with VDE 0530 Part 1.

Standard protection class: IP55. Temperature class F. Other SEW motors on enquiry.

Notes: If the free shaft end of the motor is used as shaft for a slip-on emergency hand wheel, a device will be required that interrupts the power supply before the crank engages. Motors with different speeds and brake motors on enquiry.

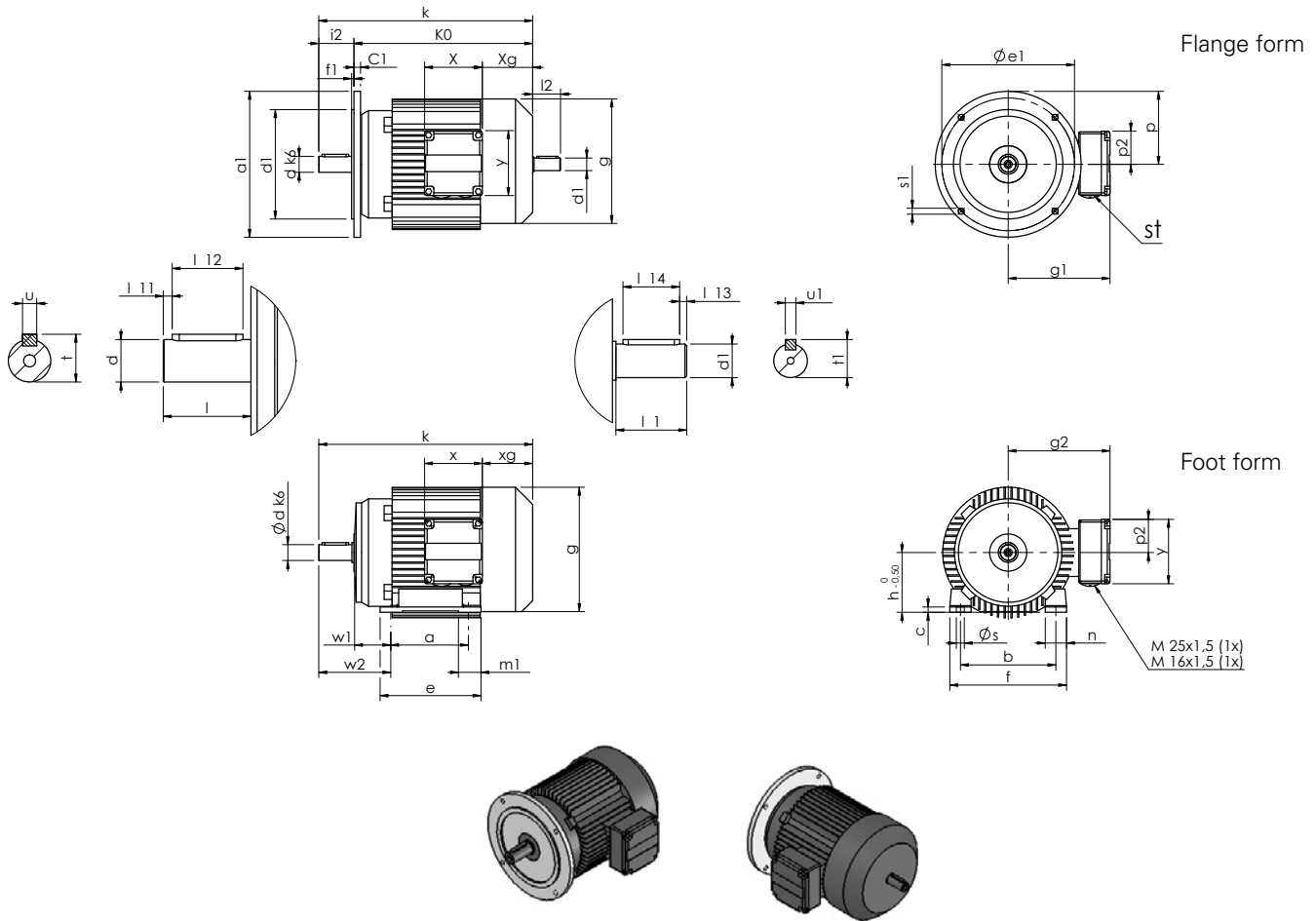

Performance data

Size	Nominal power [kW]	Nominal speed [rpm]	Power factor $\cos \varphi$	Nominal current at 400 V [A]	Rel. starting current I_A/I_N	Nominal torque [Nm]	Rel. starting torque M_A/M_N	Rel. run-up torque M_H/M_N	Moment of inertia J_{Mot} [10^{-4}kgm^2]	Moment of inertia $J_{Bremsmot}$ [10^{-4}kgm^2]	Braking torque [Nm]
DT71K4	0.15	1380	0.67	0.61	2.9	1.0	1.8	1.7	4.6	5.5	5.0
DT71C4	0.25	1380	0.70	0.80	2.8	1.7	1.8	1.7	4.6	5.5	5.0
DT71D4	0.37	1380	0.76	1.15	3.0	2.6	1.8	1.7	4.6	5.5	5.0
DT80K4	0.55	1360	0.72	1.75	3.4	3.9	2.1	1.8	7.5	7.5	10
DT80N4	0.75	1380	0.73	2.1	3.8	5.2	2.2	2.0	8.7	9.6	10
DT90S4	1.1	1400	0.77	2.8	4.3	7.5	2.0	1.9	25	31	20
DT90L4	1.5	1410	0.78	3.55	5.3	10.2	2.6	2.3	34	40	20
DV100M4	2.2	1410	0.83	4.7	5.9	15.0	2.7	2.3	53	59	40
DV100L4	3.0	1400	0.83	6.3	5.6	20.5	2.7	2.2	65	71	40
DV112M4	4.0	1420	0.84	8.7	5.4	26.9	2.4	2.1	98	110	55

3-phase motors M

Dimensions

The values in brackets refer to motors with brake.

Flange shape

Size	Dimensions [mm]													
	a ₁	b ₁	c ₁	d	d ₁	e ₁	f ₁	g	g ₁	i ₂	k	k ₀	l	l ₁₁
DFT71K4	120	80	8	14	11	100	3	145	122(127)	24	232 (296)	208 (296)	30	4
DFT71C4	120	80	8	14	11	100	3	145	122(127)	24	232 (296)	208 (272)	30	4
DFT71D4	120	80	8	14	11	100	3	145	122(127)	24	232 (296)	208 (272)	30	4
DFT80K4	120	80	8	19	14	100	3	145	122(127)	34	292 (356)	258 (322)	40	4
DFT80N4	120	80	8	19	14	100	3	145	122(127)	34	292 (356)	258 (322)	40	4
DFT90S4	160	110	10	24	19	130	3.5	197	154(161)	53.5	323 (408)	273 (358)	50	5
DFT90L4	160	110	10	24	19	130	3.5	197	154(161)	53.5	323 (408)	273 (358)	50	5
DFV100M4	200	130	10	28	19	165	3.5	197	166	60	371 (456)	311 (396)	60	5
DFV100L4	200	130	10	28	19	165	3.5	197	166	60	401 (486)	341 (426)	60	5
DFV112M4	200	130	11	28	24	165	3.5	221	179(182)	64	409 (489)	345 (425)	60	5

Size	Dimensions [mm]													
	l ₁₂	l ₁	l ₂	l ₁₃	l ₁₄	s ₁	t	u	t ₁	u ₁	x	x _g	y	p ₂
DFT71K4	22	23	24	1	20	6.6	16	5	12.5	4	87 (127)	61 (86)	97	50
DFT71C4	22	23	24	1	20	6.6	16	5	12.5	4	87 (127)	61 (86)	97	50
DFT71D4	22	23	24	1	20	6.6	16	5	12.5	4	87 (127)	61 (86)	97	50
DFT80K4	32	30	31	4	22	6.6	21.5	6	16	5	87 (127)	61 (86)	97	50
DFT80N4	32	30	31	4	22	6.6	21.5	6	16	5	87 (127)	61 (86)	97	50
DFT90S4	40	40	42	4	32	9	27	8	21.5	6	87 (127)	76 (121)	97	50
DFT90L4	40	40	42	4	32	9	27	8	21.5	6	87 (127)	76 (121)	97	50
DFV100M4	50	40	42	4	32	11	31	8	21.5	6	106 (139)	74 (125)	109	56
DFV100L4	50	40	42	4	32	11	31	8	21.5	6	106 (139)	74 (125)	109	56
DFV112M4	50	50	55	5	40	11	31	8	27	8	106 (139)	91 (131)	109	56

Foot shape

Size	Dimensions [mm]											
	a	b	c	e	f	h	m ₁	n	s	w ₁	w ₂	
DT71K4	90	112	5	115	144	71	32	31	7	45	75	
DT71C4	90	112	5	115	144	71	32	31	7	45	75	
DT71D4	90	112	5	115	144	71	32	31	7	45	75	
DT80K4	100	125	10	125	149	80	28	33	9	50	90	
DT80N4	100	125	10	125	149	80	28	33	9	50	90	
DT90S4	125	140	8	152	176	90	32	32	9	56	106	
DT90L4	125	140	8	152	176	90	32	32	9	56	106	
DV100M4	140	160	12	170	188	100	35	38	12	63	123	
DV100L4	140	160	12	170	188	100	35	38	12	63	123	
DV112M4	140	190	14	170	220	112	35	44	12	70	130	

Handwheels HR

Handwheel HR for the emergency adjustment and manual adjustment of worm gear screw jacks or systems.

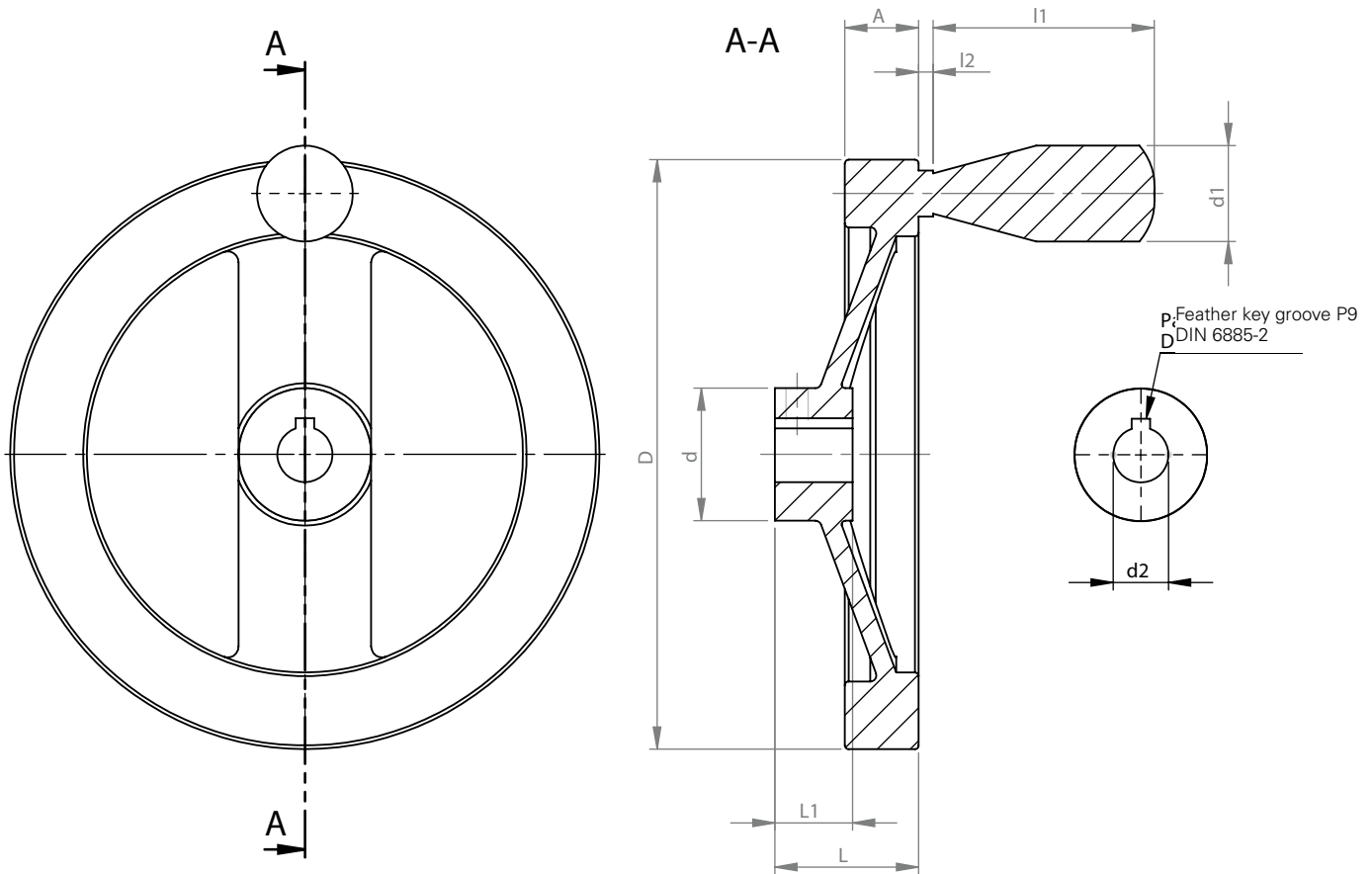

Size	Dimensions in [mm]								Bore d2 H7
	A	D	d	d1	L1	L	l1	l2	
HR 80	10	80	31	21	16	29	50	2.5	Ø 10
HR 80	10	80	31	21	16	29	50	2.5	Ø 14
HR 100	10	100	33	21	17	33	50	2.5	Ø 10
HR 100	10	100	33	21	17	33	50	2.5	Ø 14
HR 125	13	125	35	22	18	36	56	2.5	Ø 10
HR 125	13	125	35	22	18	36	56	2.5	Ø 14
HR 140	13	140	37	22	19	39	56	2.5	Ø 14
HR 140	13	140	37	22	19	39	56	2.5	Ø 16
HR 160	16	160	40	23	20	40	65	2.5	Ø 14
HR 160	16	160	40	23	20	40	65	2.5	Ø 16
HR 200	16	200	45	26	24	45	80	2.5	Ø 16
HR 200	16	200	45	26	24	45	80	2.5	Ø 20
HR 250	19	250	52	31	28	50	102	2.5	Ø 20
HR 250	19	250	52	31	28	50	102	2.5	Ø 25

Safety handwheels SHR

Safety handwheel SHR for the emergency adjustment and manual adjustment of worm gear screw jacks or systems. Safety handwheels decouple themselves to prevent turning with the spindle. Standstill of the handwheel is guaranteed only up to medium speeds.

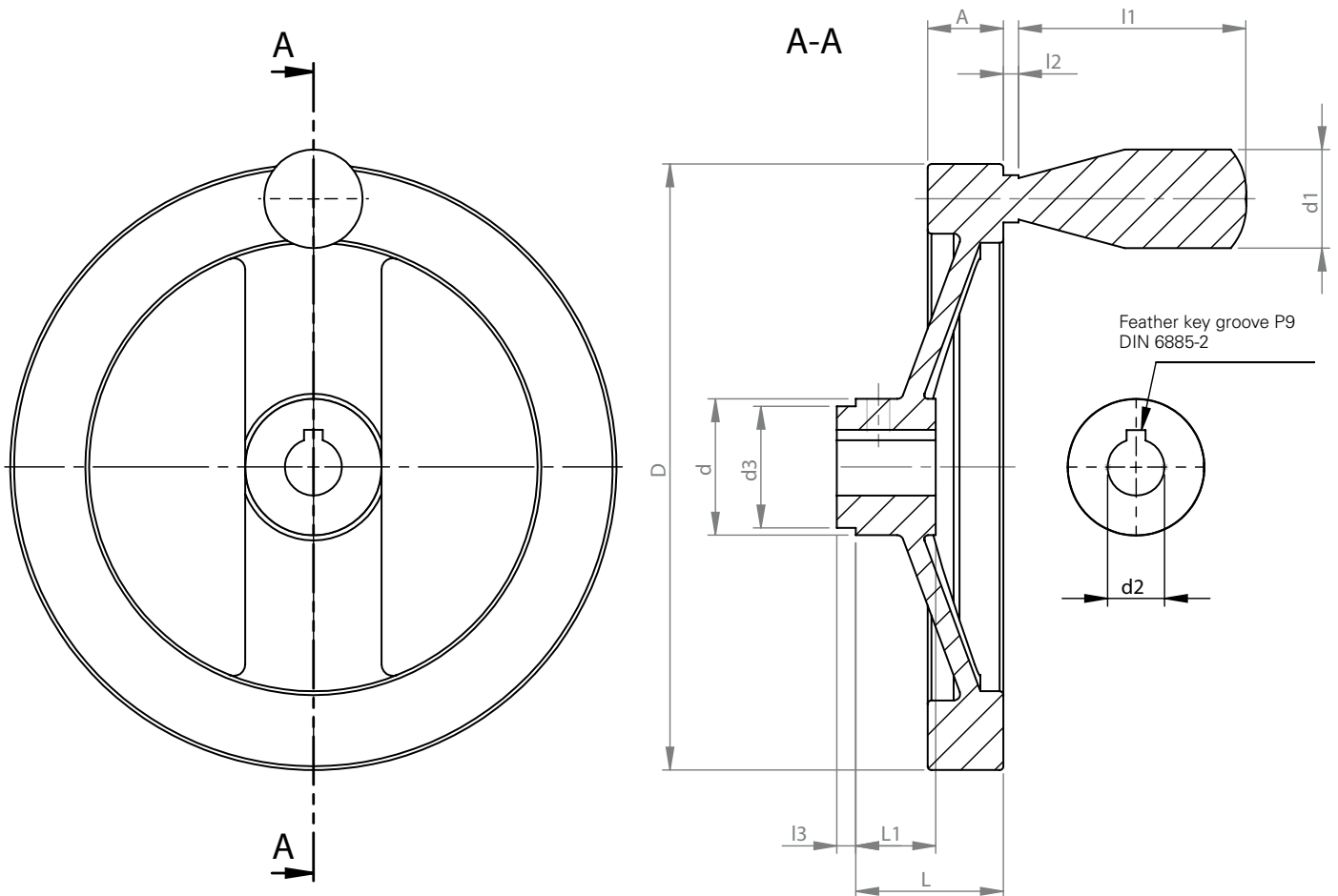

Size	Dimensions in [mm]										Bore d2 H7
	A	D	d	d1	d3	L	L1	l1	l2	l3	
HR 125	13	125	35	22	28	36	18	56	2.5	5	Ø 14
HR 140	13	140	37	22	28	39	19	56	2.5	5	Ø 14
HR 140	13	140	37	22	28	39	19	56	2.5	5	Ø 16
HR 160	16	160	40	23	32	40	20	65	2.5	6	Ø 14
HR 160	16	160	40	23	32	40	20	65	2.5	6	Ø 16
HR 200	16	200	45	26	38	45	24	80	2.5	6	Ø 18
HR 200	16	200	45	26	38	45	24	80	2.5	6	Ø 20
HR 250	19	250	52	31	45	50	28	102	2.5	12	Ø 22

Motor adaptor flanges MG

Motor adaptor flanges are used to mount motors to worm gear screw jacks and house the coupling for connecting the motor to the drive shaft.

When ordering, please specify the side at which the motor adaptor flange is to be attached (A or B).

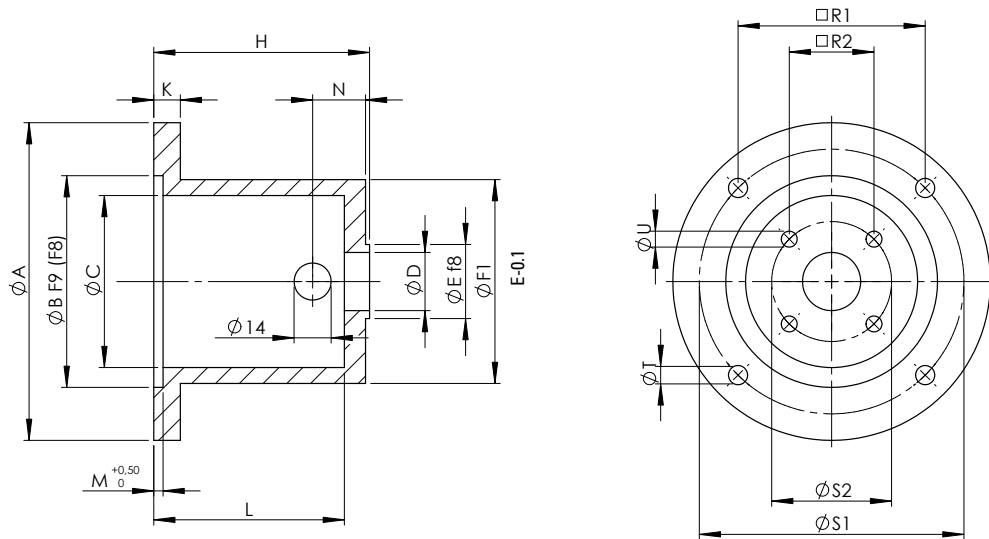

Size	Motor	Version MG/ZF ¹⁾	Dimensions [mm]									
			A	B	C	D	E	Ø F	□ F	H	I	K
MG M 0	DFT63	MG	90	60	44	19	22	50		62	61	10
MG M 1	DFT71	MG	120	80	65	22	32	77		81.5	80	10
MG M 1	DFT80	MG	120	80	56	22	32	62		91.5	90	10
MG M 2	DFT71	MG	120	80	65	26	35	77		81.5	80	10
MG M 2	DFT80	MG	120	80	78	26	35	88		92.5	91	10
MG M 2	DFT90	MG	160	110	90	31	35	110		109.5	108	15
MG M 3	DFT71	MG	120	80	77	28	40	87		91.5	90	10
MG M 3	DFT80	MG	120	80	78	28	40	88		103	101	10
MG M 3	DFT90	MG	160	110	95	28	40	104		125	123	12
MG M 3	DFV100/112	MG + ZF	200	130	100	24	35	145		133	131	29
MG M 4	DFT80	MG	120	80	75	42	52	–	88	105	103	12
MG M 4	DFT90	MG	160	110	98	42	52	114		118	116	15
MG M 4	DFV100/112	MG + ZF	200	130	120	30	52	145		134	131	29
MG M 5	DFT90	MG	160	110	105	45	62	120		138.5	136	15
MG M 5	DFV100/112	MG	200	130	125	35	62	145		154	152	16

¹⁾ MG = Motor adaptor flange
ZF = Intermediate flange

Motor adaptor flanges MG

Motor adaptor flanges are used to mount motors to worm gear screw jacks and house the coupling for connecting the motor to the drive shaft.

When ordering, please specify the side at which the motor adaptor flange is to be attached (A or B).

Dimensions [mm]									Coupling Size	Coupling half ¹⁾ M	Coupling half ¹⁾ Motor
L	M	N	□ R ₁	□ R ₂	S ₁	S ₂	T	U			
53	3	20	53	24	75	33.9	6	5.5	RA14	RA14 Ø9	RA14 Ø11
72	3.5	20	70.7	32	100	45.3	6.6	5.5	RA19	RA19 Ø10	RA19 Ø14
85	3.5	20	70.7	32	100	45.3	6.6	5.5	RA19	RA19 Ø10	RA19 Ø19
73	3.5	22	70.7	35	100	49.5	6.6	6.6	RA19	RA19 Ø14	RA19 Ø14
84	3.5	22	70.7	35	100	49.5	6.6	6.6	RA19	RA19 Ø14	RA19 Ø19
100	4	27	92	35	130	49.5	9	6.6	RA24	RA24 Ø14	RA24 Ø24
83	3.5	27	70.7	44	100	62.2	6.6	9	RA19	RA19 Ø16	RA19 Ø14
93	3.5	32	70.7	44	100	62.2	6.6	9	RA19	RA19 Ø16	RA19 Ø19
114	4	30	92	44	130	62.2	9	9	RA24	RA24 Ø16	RA24 Ø24
119	4.5	40	116.7	44	165	62.2	M10	9	RA28	RA28 Ø16	RA28 Ø28
94	3.5	35	70.7	55	100	78	6.6	11	RA24	RA24 Ø20	RA24 Ø19
106	4	30	92	55	130	78	M8	11	RA24	RA24 Ø20	RA24 Ø24
119	4.5	38	116.7	55	165	78	M10	11	RA28	RA28 Ø20	RA28 Ø28
122	4	48	92	70	130	99	M8	13.5	RA28	RA28 Ø25	RA28 Ø24
138	7	50	116.7	70	165	99	M10	13.5	RA28	RA28 Ø25	RA28 Ø28

¹⁾ When ordering, the bore diameter of the coupling half on the motor side must be explicitly stated.

Ordering code for motor adaptor flange MG

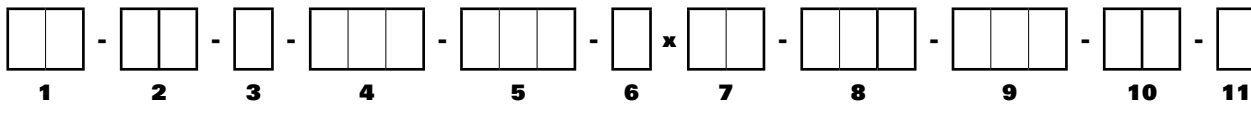

No.	Designation	Code	Description
1	Product abbreviation	MG	
2	Gear designation	M1, M2,..	Sequential sizes – worm gear screw jacks
		J1, J2, ...	Sequential sizes – worm gear screw jacks
		G1, G2, ...	Sequential sizes – high-speed screw jacks
3	Version	R	Round
		V	Square
4	Centring diameter of motor flange in [mm]		
5	Outside diameter of motor flange in [mm]		
6	Number of pitch circle bores		Number of bores on the motor flange
7	Size/thread size of the pitch circle bores		e.g. 6.5 for 6.5 mm diameter (flange form B14) e.g. M6 for a M6 thread (flange form B5)
8	Pitch circle diameter of motor flange in [mm]		
9	Length without bearing centring attachment in [mm]		Determined by length of the shaft extension and dimension B of the coupling
10	Material	AL	Aluminium alloy
		ZI	Zinc-phosphated steel
		A2	Rust-resistant
		A4	Rust, acid and seawater-resistant
11	Special requirements	0	None
		1	According to specification, description or drawing

Couplings

Shaft couplings GS

The GS shaft coupling is a special anti backlash shaft coupling.

The toothed ring is installed under pre-tension, resulting in a low surface pressure and hence increased rigidity of the system.

This shaft coupling has proved itself due to its flawless function and durability at high speeds and under strong acceleration.

We recommend this shaft coupling with clamping hub or clamping ring hub.

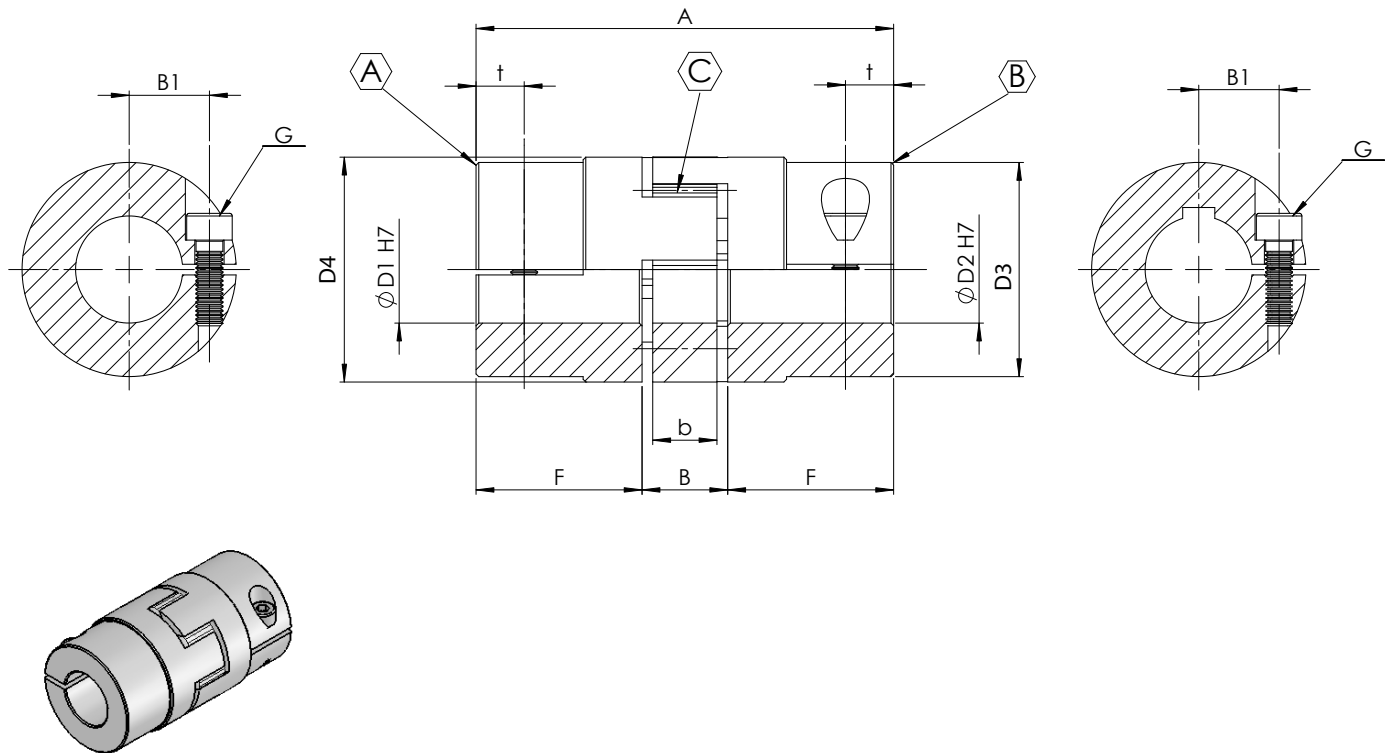

Size	D ₁ H ⁷	D ₂ H ⁷	D ₃	D ₄	A	F	t	b	B	B ₁	G
WK-GS-9	6-9	6-9	20	23.5	30	10	5	8	10	7.5	M2
WK-GS-14	6-14	6-14	30	32.5	35	11	5	10	13	11.5	M3
WK-GS-19	10-20	10-20	40	46	66	25	12	12	16	14.5	M6
WK-GS-24	10-28	10-28	55	57	78	30	14	14	18	14.5	M6
WK-GS-28	19-38	19-39	65	72.6	90	35	15	15	20	20	M8

Couplings

Shaft couplings RA, RG

The RA or RG shaft couplings are particularly torsionally flexible. They compensate smaller angular, radial and axial shaft displacements. They protect worm gear screw jacks, bevel gearboxes and motors thanks to their shock and vibration damping effect.

Version 1

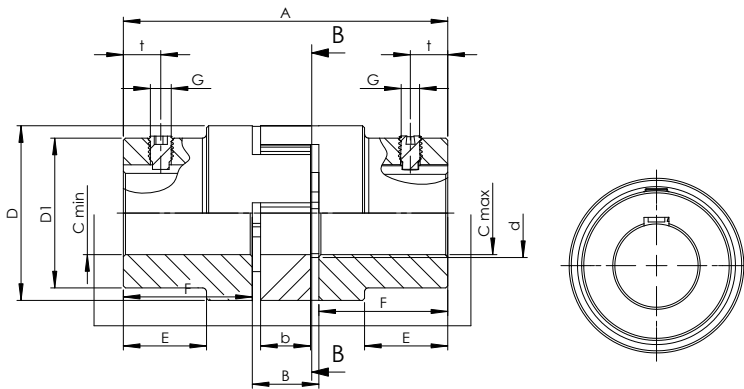

Version 1a

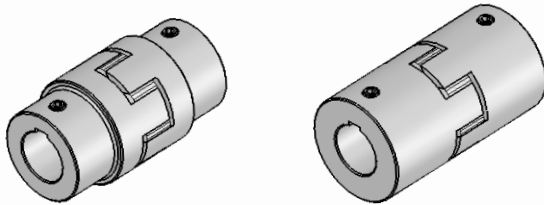
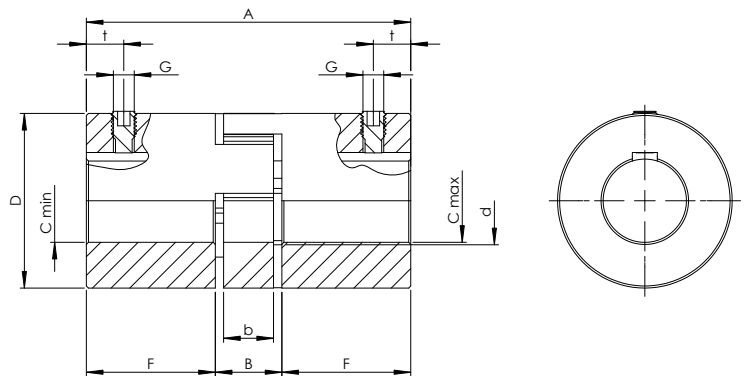

Size	Version	Max. M_d [Nm]	Dimensions [mm]										Offsets				Locking screw		Weight [kg]
			A_1	E	F	B	b	D_1	D	d	$C_{min}^{1)}$	$C_{max}^{1)}$	max.axial displacement ΔK_a [mm]	max. radial non-alignment $n=1500$ 1/min. ΔK_r [mm]	max. angular displacement bei $n=1500$ 1/min. ΔK_w [Grad] ΔK_w [mm]		Dim.	Dim.	
																G	t		
RA 14	1a	7,5	35	-	11	13	10	-	30	10	6	15	1,0	0,17	1,2	0,67	M4	5	0,05
RA 19	1	10	66	20	25	16	12	32	40	18	10	19	1,2	0,20	1,2	0,82	M5	10	0,15
RA 19	1a	10	66	-	25	16	12	-	41	18	19	24	1,2	0,20	1,2	0,82	M5	10	0,15
RA 24	1	35	78	24	30	18	14	40	55	27	14	24	1,4	0,22	0,9	0,85	M5	10	0,25
RA 24	1a	35	78	-	30	18	14	-	56	27	22	28	1,4	0,22	0,9	0,85	M5	10	0,35
RA 28	1	95	90	28	35	20	15	48	65	30	14	28	1,5	0,25	0,9	1,05	M6	15	0,40
RA 28	1a	95	90	-	35	20	15	-	67	30	28	38	1,5	0,25	0,9	1,05	M6	15	0,55
RG 38	1	190	114	37	45	24	18	66	80	38	16	38	1,8	0,28	1,0	1,35	M8	15	0,85
RG 42	1	265	126	40	50	26	20	75	95	46	28	42	2,0	0,32	1,0	1,70	M8	20	1,2
RG 48	1	310	140	45	56	28	21	85	105	51	28	48	2,1	0,36	1,1	2,00	M8	20	1,7
RG 55	1	410	160	52	65	30	22	98	120	60	30	55	2,2	0,38	1,1	2,30	M10	20	7,3
RG 65	1	625	185	61	75	35	26	115	135	68	40	65	2,6	0,42	1,2	2,70	M10	20	11,0
RG 75	1	975	210	69	85	40	30	135	160	80	40	75	3,0	0,48	1,2	3,30	M10	25	17,9
RG 90	1	2400	245	81	100	45	34	160	200	100	50	90	3,4	0,50	1,2	4,30	M12	30	28,5

¹⁾ This catalogue does not list all intermediate sizes.
Further sizes on enquiry.

The threaded bore G for the locking screw is located opposite the feather key groove.

Universal joint shaft ZR

The ZR universal joint shaft is particularly torsionally flexible and serves to bridge large shaft distances at rotary speeds of up to 1500 rpm. Thanks to the double arrangement of the toothed rings, large radial displacements are possible with good damping characteristics. The ZR universal joint shaft can be mounted radially without shifting the gearbox or the motor.

Selection B-B

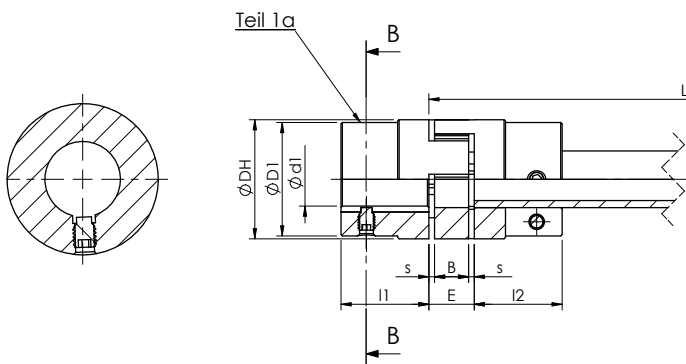

Selection A-A

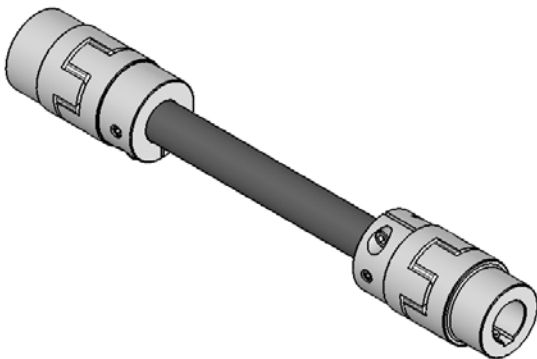
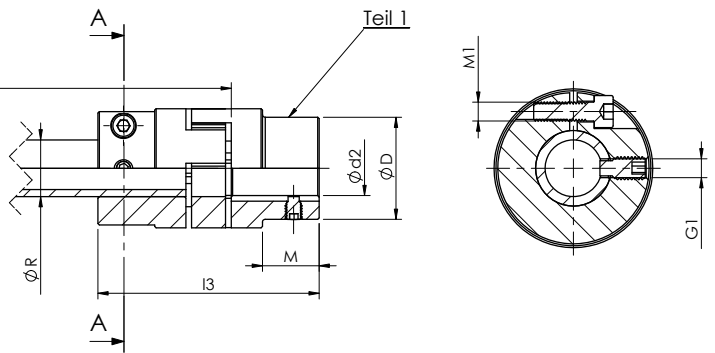

Size	Manufacturing bore $\text{ØdH7}^{2)}$		Part 1a		Ø DH	Ø D	Ø D1	ØdH	l1	l2	M	s	b	E	l3	ØR	G1	dp
	min Ød2	max Ød2	min Ød1	max Ød1														
ZR 14	-	-	4	14	30	-	30	10.5	11	-	1.5	10	13	35	14x2	M4	2.5	
ZR 19	6	19	19	24	40	32	41	18	25	20	2	12	16	66	20x3	M6	4	
ZR 24	8	24	24	28	55	40	55	27	30	24	2	14	18	78	30x4	M8	5.5	
ZR 28	10	28	28	38	65	48	65	30	35	28	2.5	15	20	90	35x4	M10	7	
ZR 38	12	38	38	45	80	66	77	38	45	37	3	18	24	114	40x4	M12	8.5	
ZR 42	28	42	42	55	95	75	94	46	50	40	3	20	26	126	45x4	M12	8.5	
ZR 48	28	48	48	60	105	85	102	51	56	45	3.5	21	28	140	50x4	M16	12	

Universal joint shaft GX

Torsionally rigid universal joint shafts are used to connect several worm gear screw jacks. The shafts attenuate noise, vibrations and impacts and compensate for axial, radial and angular errors. They offer exceptional torsional rigidity, high temperature and oil resistance and are particularly suitable where long lengths and/or high speeds are required. Elastic universal joint shafts are maintenance-free; the central section can be removed radially (to the side) without axial displacement of the connected units.

They are supplied as a length of tube (dimension L to be specified by customer) fitted with coupling assemblies at both ends. Pedestal bearings are generally not required, except for very long connections. For optimum alignment of the screw jacks, we recommend the use of universal joint shafts with clamping sets

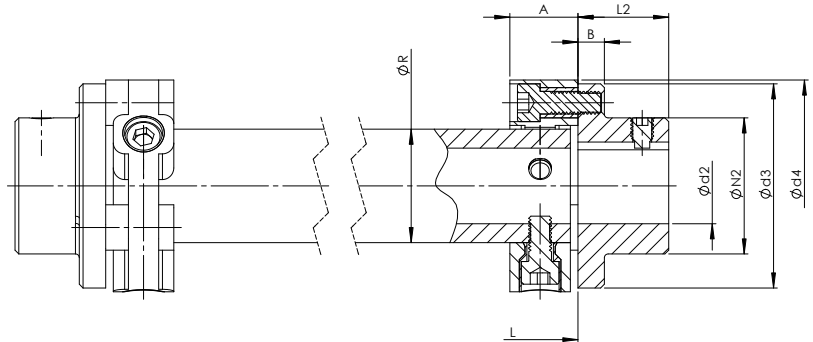
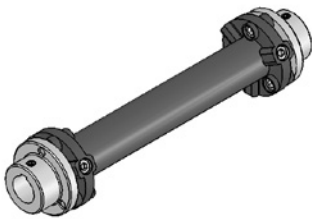

Size	A	B	C	Ø d ₃	Pilot hole d	Manufacturing bore ØdH7 2) D max ⁽²⁾	E	F	L ₂	Ø N ₂	Ø R	T	T _k / M
GX - 1	24	7	5	56	8	25	22	2	24	36	30	1.5	Ø44/2xM6
GX - 2	24	8	5	85	12	38	20	4	28	55	40	1.5	Ø68/2xM8
GX - 4	28	8	5	100	15	45	24	4	30	65	45	1.5	Ø80/3xM8
GX - 8	32	10	5	120	18	55	28	4	42	80	60	1.5	Ø100/3xM10
GX - 16	42	12	5	150	20	70	36	6	50	100	70	1.5	Ø125/3xM12
GX - 25	46	14	5	170	20	85	40	6	55	115	85	1.5	Ø140/3xM14
GX - 30	58	16	5	200	25	100	50	8	66	140	100	1.5	Ø165/3xM16
GX - 50	58	16	5	200	25	100	50	8	66	140	100	1.5	Ø165/3xM16
GX - 90	70	19	5	260	30	110	62	8	80	160	125	2	Ø215/3xM20

Universal joint shaft diagram

as a function of length and speed

permissible speed = speed of rotation * 0,8

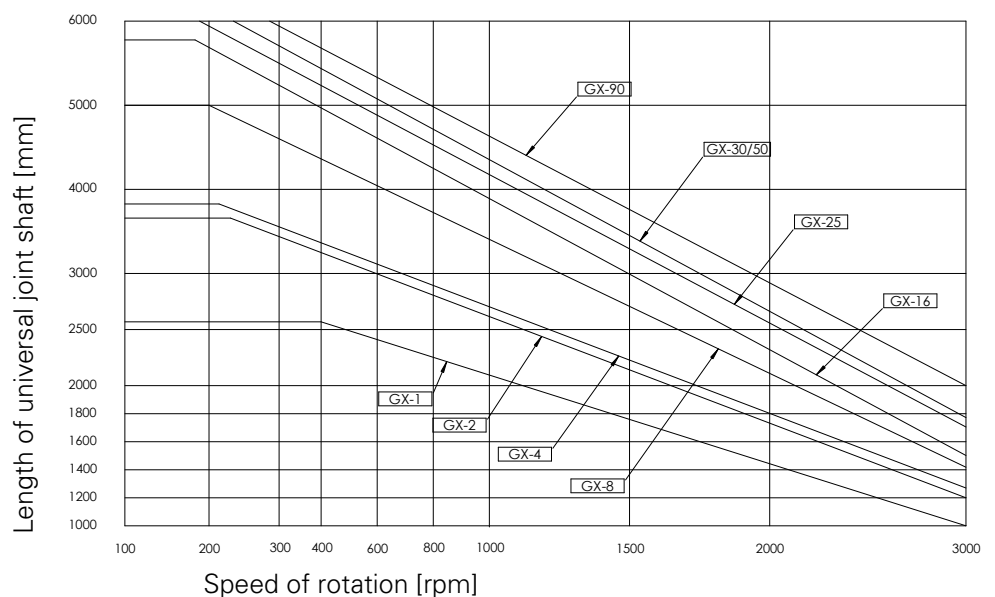

Universal joint shaft GX

Length of the universal joint shaft for screw jacks M with feather key groove

M 0

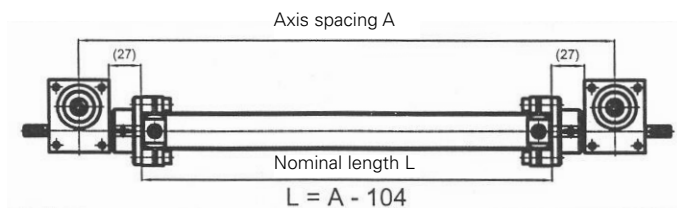

M 1

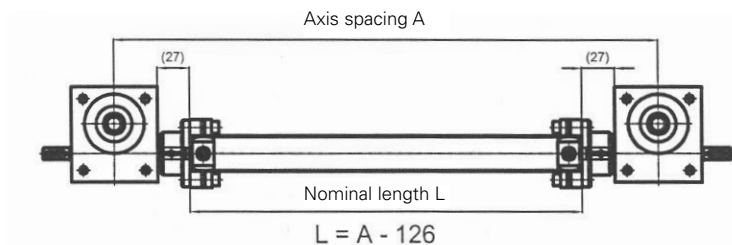

M 2

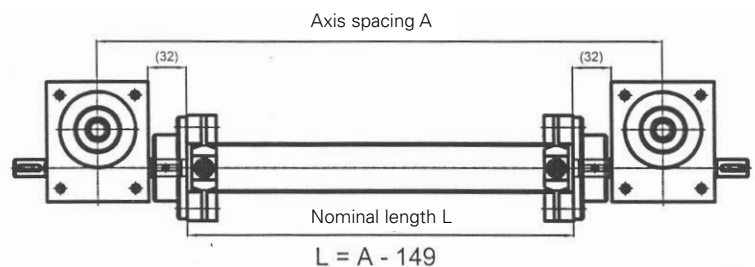

M 3

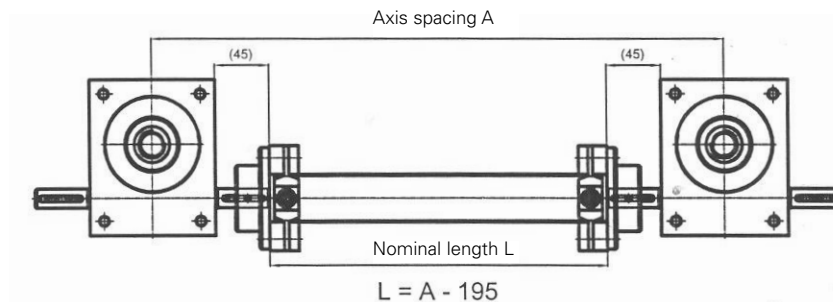

M 4

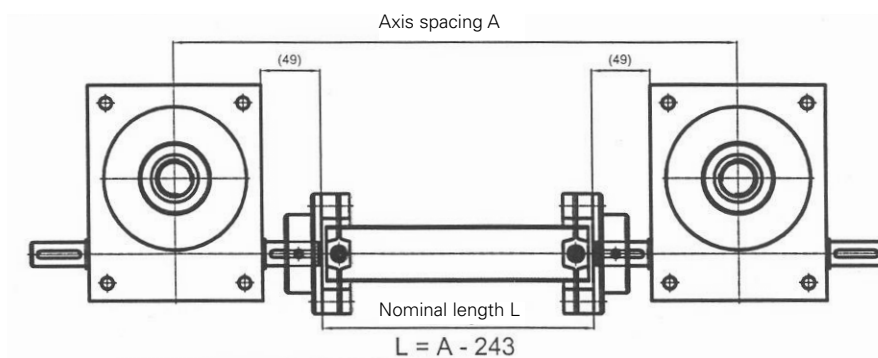

M 5

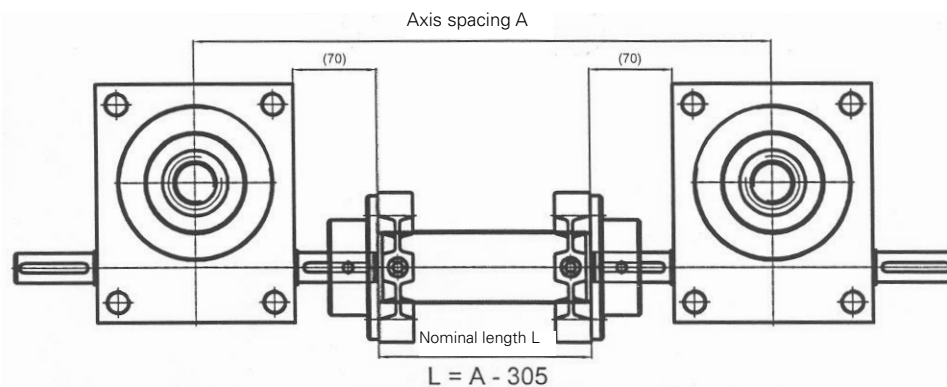

Pedestal bearings SN

The pedestal bearings conforming to DIN 736 come complete with roller bearing, retaining bush and case with felt seals on both sides. These pedestal bearings are very well suited to the intermediate support of our GX and ZR universal joint shafts when these are very long. The retaining bush can be fixed to the outer diameter of the tube. The pedestal bearing is supplied as a movable bearing if nothing in particular is specified.

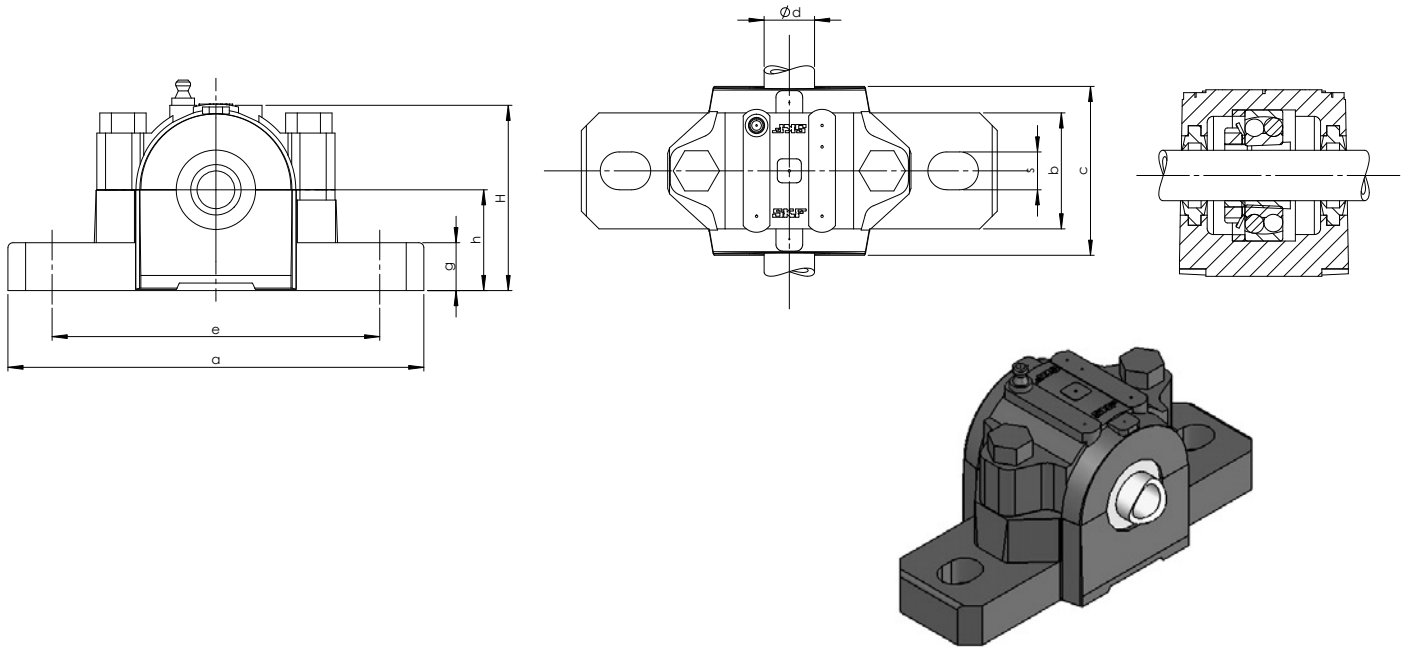

Size	Ø d	H	h	e	S	C	a	b	g (max)	Weight kg
SN 505-20	20	75	40	130	15	67	165	46	19	1.4
SN 506-25	25	90	50	150	15	77	185	52	22	1.98
SN 507-30	30	110	50	150	15	82	185	52	22	2.1
SN 508-35	35	110	60	170	15	85	205	60	25	3.1
SN 509-40	40	115	60	170	15	85	205	60	25	2.9
SN 510-50	50	130	60	170	15	90	205	60	25	3.3
SN 511-55	55	135	70	210	18	95	255	70	28	4.6
SN 512-60	60	150	70	210	18	105	255	70	30	5.4
SN 513-65	65	155	80	230	18	110	275	80	30	6.7
SN 515-70	70	175	80	230	18	115	280	80	30	7.3
SN 516-75	75	185	95	260	22	120	315	90	32	9.3
SN 517-80	80	195	95	260	22	125	320	90	32	9.8
SN 518-90	90	215	100	290	22	145	345	100	35	12.5
SN 520-100	100	240	112	320	26	160	380	110	40	15.5
SN 522-110	110	270	125	350	26	175	410	120	45	19.8

Bevel gearboxes Selection criteria

NEFF bevel gearboxes have strong grey cast iron housings, hardened bevel gears lapped in pairs with spiral toothing and adequately dimensioned roller bearings. Spiral bevel gears offer the decisive advantage of very favourable engagement ratios (high degree of overlap).

Consequently they are predestined for use under high stresses, coupled with optimum smooth running characteristics and high transmission accuracy.

The arc-shaped teeth are more resistant to bending than straight or diagonal teeth. A further advantage is the relative insensitivity to elastic deformation of gear wheels, shafts and bearings.

The gears can therefore also transmit extreme shock loads.

Three standard designs are available. 22 further variations are possible as auxiliary drives. The gearboxes can be used in all installation positions and provided with various mounting holes. Cover and flanges are generally provided with mounting holes.

Transmission ratios

The following standard transmission ratios are available: 1:1, 1.5:1, 2:1, 3:1, 4:1, 5:1 and 6:1.

All transmission ratios are mathematically precise. The gearboxes can be used as step-up and step-down gearboxes.

Custom transmission ratios are available. Please enquire.

Efficiency

The efficiency of the NEFF bevel gearboxes is 94 – 98 %, depending on speed, installation position, sealing and type of lubricant. The efficiencies refer to the rated performances of the gearboxes.

In certain installation positions the bevel gears are fully immersed into the lubricant. In case of larger gearboxes and high peripheral speeds of the gear wheels, the churning losses cannot be neglected and NEFF must be consulted.

Note that the start-up efficiency is always smaller than the operational efficiency. The resultant increased breakaway torque must be considered in the design of the drive performance.

Low-backlash version

As standard the bevel gearboxes have a circumferential backlash of 10 to 30 angular minutes, depending on the size of the transmission and the transmission ratio.

However, all NEFF bevel gearboxes can be supplied in a low-backlash version.

The circumferential backlash at the slow-running shaft is measured with the drive shaft blocked on a lever arm of 100 mm with a measuring force of 3% of the nominal torque and given as the torsion angle.

The following values are adjustable with normal gear wheel sets:

Version S1: $i = 1:1$ to $2:1 < 6$ angular minutes

Version S2: $i = 3:1$ to $6:1 < 10$ angular minutes

Tighter values require select, HPGS-toothed or polished gear wheel sets - please enquire.

Preferable direction of rotation

In principle NEFF bevel gearboxes can be driven in both directions of rotation. Together with the direction of rotation, the spiral direction of a gear wheel set determines the internal load ratios of the gearbox.

If one selects the direction of rotation of the small gear contrary to its spiral direction (viewed from the shaft end face to the centre of the gearbox), then the axial force acts outwards. As a result the gear wheel set is pressed apart and causes a lowering of the noise level by 1 - 2 dBA.

NEFF manufactures the pinion as a left-hand spiral; the preferable direction of rotation is thus clockwise.

Lubrication

NEFF bevel gearboxes are delivered with an oil filling and are maintenance-free under normal operating conditions. In case of extreme requirements or increased service life requirements, we recommend an oil change approx. every 15.000 hours of operation.

NEFF strives to select the best lubricant for each application and in this way to optimise the service life of the gearboxes.

Decisive for the choice of lubricants are the peripheral speed of the bevel gears, the power to be transmitted and the operating conditions.

An approximate guiding value for the type of lubrication used can be taken from the two selection diagrams and the lubricant table.

The correct type of lubrication can be selected on the basis of two selection diagrams and a lubricant table. The selection diagrams take into account the catalogue nominal torque and the mode of operation of the gearbox with 100% duty cycle or 30% / hr intermittent operation.

After the selection of the mode of operation and taking into consideration the operating conditions, the type of lubricant is defined with the speed of the slow-running transmission shaft. The type of lubrication, the necessity of gearbox ventilation and the gearbox oil can be taken from the lubricant table shown below.

The actual type of lubrication is defined by us for the specific application and may deviate from the table values!

There is a choice of modern synthetic high-performance lubricants. Proven lubricants with NSF-H1 approval (USDA-H1) can be selected for the use of gearboxes in the pharmaceutical or food industries.

NEFF gearboxes are provided with lifetime lubrication. Lubricant quantities are defined internally within the company for the installation position. Of course, biologically degradable oils or lubricants for extreme operating conditions can also be supplied. Please consult NEFF.

Due to the small convection surface the temperature of the gearbox can exceed 50 °C even under normal operating conditions.

If the gearbox exceeds this temperature in use, the ventilation filter provided must be installed in order to avoid overpressure in the gearbox and thus a leak in the gearbox.

The supply of fresh air must be ensured. Please consult us in cases of extreme environmental conditions (dust, moisture, etc.).

The ventilation bore can be dispensed with in case of intermittent operation or other operating conditions where the gearbox temperature is not expected to exceed 50 °C.

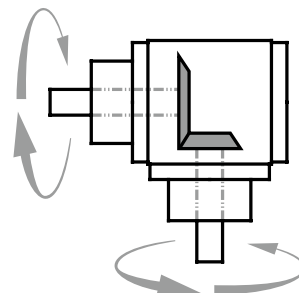

Bevel gearboxes Lubrication

Transmission ratios $i=1:1-6:1$
Ambient temperature $-10^{\circ}\text{C}-+30^{\circ}\text{C}$

Duty cycle 100%/hr

Select n2 taking into account the maximum permissible values from the performance tables!

n2 [rpm]	Gearbox size		
	065	090	120
200	A	A	A
300	A	A	A
400	A	A	A
500	A	A	A
600	A	A	A
700	A	A	B 0
800	A	B 0	B 0
900	A	B 0	B 0
1000	A	B 0	B 0
1100	A	B 0	B 0
1200	B 0	B 0	B 1
1500	B 0	B 0	B 1
1600	B 0	B 1	B 1
1700	B 0	B 1	B 1
1800	B 0	B 1	B 1
2200	B 0	B 1	B 1
3000	B 1	B 1	B 2
3400	B 1	B 2	B 2

Duty cycle 30%/hr

Select n2 taking into account the maximum permissible values from the performance tables!

n2 [rpm]	Gearbox size		
	065	090	120
400	A	A	A
500	A	A	A
700	A	A	A
800	A	A	A
900	A	A	A
1000	A	A	B 0
1100	A	A	B 0
1200	A	A	B 0
1300	A	A	B 0
1400	A	B 0	B 0
1500	A	B 0	B 0
1700	A	B 0	B 0
1900	A	B 0	B 1
2000	B 0	B 0	B 1
2200	B 0	B 0	B 1
2300	B 0	B 1	B 1
2800	B 0	B 1	B 1
3000	B 0	B 1	B 2
3300	B 0	B 1	B 2

	Code	Lubrication	Ventilation	Viscosity
Standard	A	Splash lubrication	Without	460
	B 0	Splash lubrication	Without	220
	B 1	Splash lubrication	with	220
	B 2	Splash lubrication	with	68

Position of the ventilation filter

With the lubrication types B1 and B2 the gearbox is supplied with a ventilation filter. Please refer to the table below for the possible positions of the filter. The side of the gearbox on which the filter will be mounted is to be specified in the ordering designation.

e.g.: E4 = ventilation on side 4. If nothing is specified in the order, the position of the ventilation filter is determined by NEFF.

Installation position - type V design, model A0-D0

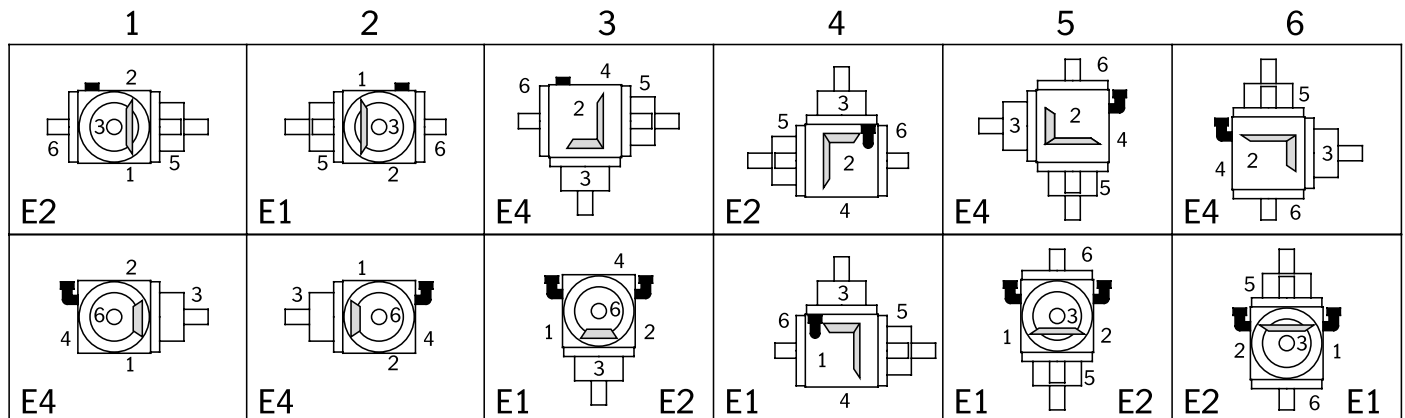

Bevel gearbox Type V

iN / ilst	n1 1/min	n2 1/min	kW Nm	065	Size 090	120
1:1 - 6:1	3000	3000	P1Nt	1.60	3.80	6.20
			T2N	3.31	8.93	21.82
1:1	2400	2400	P1N	2.65	7.41	18.52
			T2N	10.00	27.00	66.00
	1500	1500	P1N	1.82	5.29	13.56
			T2N	11.00	32.00	82.00
	1000	1000	P1N	1.32	3.75	10.14
			T2N	12.00	34.00	92.00
	750	750	P1N	1.07	3.06	8.51
			T2N	13.00	37.00	103.00
	500	500	P1N	0.83	2.20	6.34
			T2N	15.00	40.00	115.00
	250	250	P1N	0.47	1.21	3.39
			T2N	17.00	44.00	123.00
50	50	P1N	0.10	0.28	0.72	
		T2N	18.00	50.00	130.00	
		T2max	25.00	105.00	220.00	
1.5:1	3000	2000	P1N	2.20	5.51	13.45
			T2N	10.00	25.00	61.00
	2400	1600	P1N	1.76	4.59	11.46
			T2N	10.00	26.00	65.00
	1500	1000	P1N	1.21	3.20	8.60
			T2N	11.00	29.00	78.00
	1000	667	P1N	0.88	2.35	6.32
			T2N	12.00	32.00	86.00
	750	500	P1N	0.72	1.93	5.18
			T2N	13.00	35.00	94.00
	500	333	P1N	0.55	1.36	3.85
			T2N	15.00	37.00	105.00
250	167	P1N	0.31	0.74	1.99	
		T2N	17.00	40.00	108.00	
50	33	P1N	0.07	0.16	0.41	
		T2N	18.00	45.00	113.00	
		T2max	25.00	80.00	169.00	
2:1	3000	1500	P1N	1.65	3.80	9.26
			T2N	10.00	23.00	56.00
	2400	1200	P1N	1.32	3.17	8.07
			T2N	10.00	24.00	61.00
	1500	750	P1N	0.91	2.23	6.03
			T2N	11.00	27.00	73.00
	1000	500	P1N	0.66	1.71	4.46
			T2N	12.00	31.00	81.00
	750	375	P1N	0.54	1.32	3.55
			T2N	13.00	32.00	86.00
	500	250	P1N	0.41	0.94	2.54
			T2N	15.00	34.00	92.00
250	125	P1N	0.23	0.50	1.35	
		T2N	17.00	36.00	98.00	
50	25	P1N	0.05	0.10	0.29	
		T2N	18.00	37.00	107.00	
		T2max	25.00	80.00	169.00	
3:1	3000	1000	P1N	1.10	2.54	6.39
			T2N	10.00	23.00	58.00
	2400	800	P1N	0.88	2.12	5.56
			T2N	10.00	24.00	63.00
	1500	500	P1N	0.61	1.49	4.08
			T2N	11.00	27.00	74.00
	1000	333	P1N	0.44	1.14	3.01
			T2N	12.00	31.00	82.00

iN / ilst	n1 1/min	n2 1/min	kW Nm	065	Size 090	120	
3:1	750	250	P1N	0.33	0.88	2.40	
			T2N	12.00	32.00	87.00	
	500	167	P1N	0.24	0.63	1.66	
			T2N	13.00	34.00	90.00	
	250	83	P1N	0.12	0.33	0.87	
			T2N	13.00	36.00	95.00	
	50	17	P1N	0.03	0.07	0.21	
			T2N	14.00	37.00	110.00	
			T2max	23.00	70.00	155.00	
	4:1	3000	750	P1N		1.90	4.96
				T2N		23.00	60.00
		2400	600	P1N		1.65	4.43
T2N					25.00	67.00	
1500		375	P1N		1.12	3.06	
			T2N		27.00	74.00	
1000		250	P1N		0.85	2.18	
			T2N		31.00	79.00	
750		187.5	P1N		0.66	1.69	
			T2N		32.00	82.00	
500		125	P1N		0.47	1.16	
			T2N		34.00	84.00	
250	62.5	P1N		0.25	0.60		
		T2N		36.00	87.00		
50	12.5	P1N		0.05	0.12		
		T2N		37.00	90.00		
		T2max		70.00	155.00		
5:1	3000	600	P1N		1.52	3.97	
			T2N		23.00	60.00	
	2400	480	P1N		1.32	3.44	
			T2N		25.00	65.00	
	1500	300	P1N		0.89	2.38	
			T2N		27.00	72.00	
	1000	200	P1N		0.68	1.76	
			T2N		31.00	80.00	
	750	150	P1N		0.53	1.42	
			T2N		32.00	86.00	
	500	100	P1N		0.37	0.98	
			T2N		34.00	89.00	
250	50	P1N		0.20	0.51		
		T2N		36.00	92.00		
50	10	P1N		0.04	0.10		
		T2N		37.00	95.00		
		T2max		60.00	140.00		
6:1	3000	600	P1N		1.25	2.95	
			T2N		23.00	54.00	
	2400	480	P1N		1.09	2.53	
			T2N		25.00	57.00	
	1500	300	P1N		0.74	1.75	
			T2N		27.00	64.00	
	1000	200	P1N		0.53	1.22	
			T2N		29.00	66.00	
	750	150	P1N		0.40	0.94	
			T2N		29.00	68.00	
	500	100	P1N		0.27	0.63	
			T2N		29.00	69.00	
250	50	P1N		0.14	0.33		
		T2N		30.00	71.00		
50	10	P1N		0.03	0.06		
		T2N		33.00	66.00		
		T2max		50.00	120.00		

Bevel gearbox Typ V 065

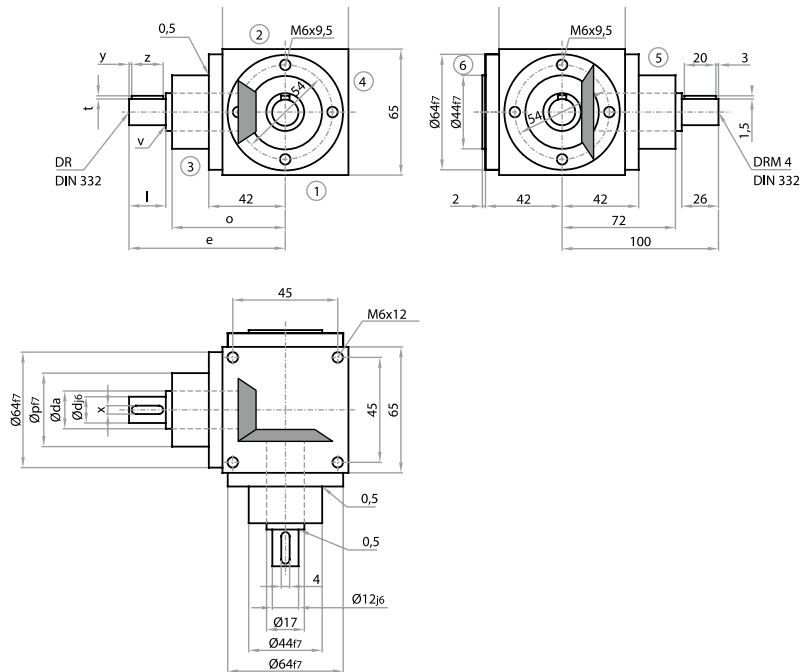

Design

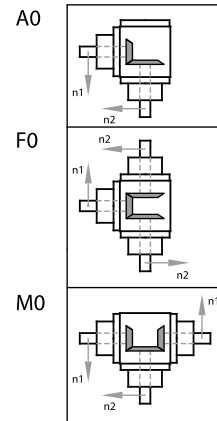

Caution: Caution: standard mounting threads in the housing only on sides 1, 2 & 4.
Alternatively also possible on sides 3, 5 & 6 in the gird size 54 x 54.

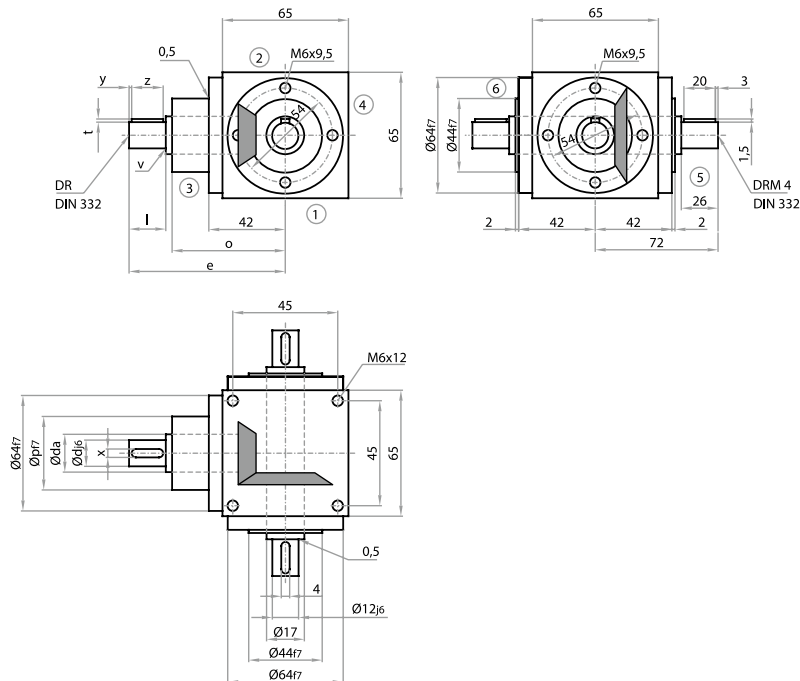

Design

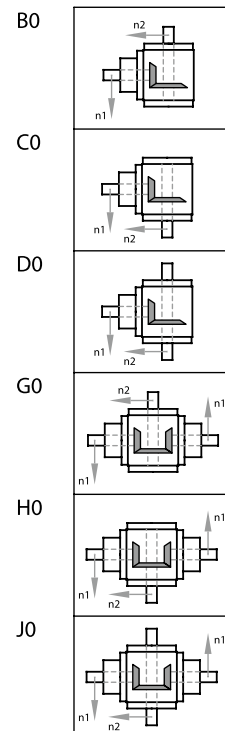

Caution: Caution: standard mounting threads in the housing only on sides 1, 2 & 4.
Alternatively also possible on sides 3, 5 & 6 in the gird size 54 x 54.

Transmission ratio

Transmission ratio	d	da	l	v	x	y	z	t	DR	e	o	p
i = 1:1 - 2:1	12	17	26	0,5	4	3	20	1,5	M4	100	72	44

Transmission ratio	d	da	l	v	x	y	z	t	DR	e	o	p
i = 3:1	12	17	26	0,5	4	3	20	1,5	M4	100	72	44

Bevel gearbox Type V 065

Performances, torques

[n = min-1, P = kW, T = Nm]

i = n1	1:1 n2	P1N T2N	1,5:1 n2	P1N T2N	2:1 n2	P1N T2N	3:1 n2	P1N T2N
3000	3000	3.31 10.00	2000	2.20 10.00	1500	1.65 10.00	1000	1.10 10.00
2400	2400	2.65 10.00	1600	1.76 10.00	1200	1.32 10.00	800	0.88 10.00
1500	1500	1.82 11.00	1000	1.21 11.00	750	0.91 11.00	500	0.61 11.00
1000	1000	1.32 12.00	667	0.88 12.00	500	0.66 12.00	333	0.44 12.00
750	750	1.07 13.00	500	0.72 13.00	375	0.54 13.00	250	0.33 12.00
500	500	0.83 15.00	333	0.55 15.00	250	0.41 15.00	167	0.24 13.00
250	250	0.47 17.00	167	0.31 17.00	125	0.23 17.00	83	0.12 13.00
50	50	0.10 18.00	33	0.07 18.00	25	0.05 18.00	17	0.03 14.00
P1Nt T2max		1.60 25.00		1.60 25.00		1.60 25.00		1.60 23.00

Radial forces (N)

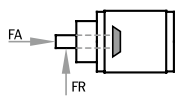

T2 Nm	n1 (1/min)					
	3000	1000	500	250	100	50
< 12	180	250	300	350	450	550
> 12	150	210	250	290	380	460

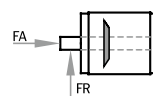

n2 (1/min)					
3000	1000	500	250	100	50
300	400	500	650	750	900
250	330	420	540	630	750

For further explanations and reinforced bearings, see General
Axial forces FA = 50% of the radial forces - see General

Mass moment of inertia J (kgcm²)

reduced to the drive shaft (n1)

Size	Dimension			
	1:1	1,5:1	2:1	3:1
A0	0.3888	0.2406	0.1839	0.1036
F0	0.5832	0.3270	0.2325	0.1252
M0	0.5832	0.3948	0.3192	0.1856
B0, C0	0.4231	0.3111	0.2330	0.1001
D0	0.4330	0.3155	0.2355	0.1012
G0, H0	0.6175	0.4653	0.3683	0.1821
J0	0.6274	0.4697	0.3708	0.1832

Gearbox weight (kg)

Size	approx. weight
A0	2.3
F0	2.7
M0	2.7
B0, C0	2.2
D0	2.3
G0, H0	2.6
J0	2.7

Bevel gearbox Type V 090

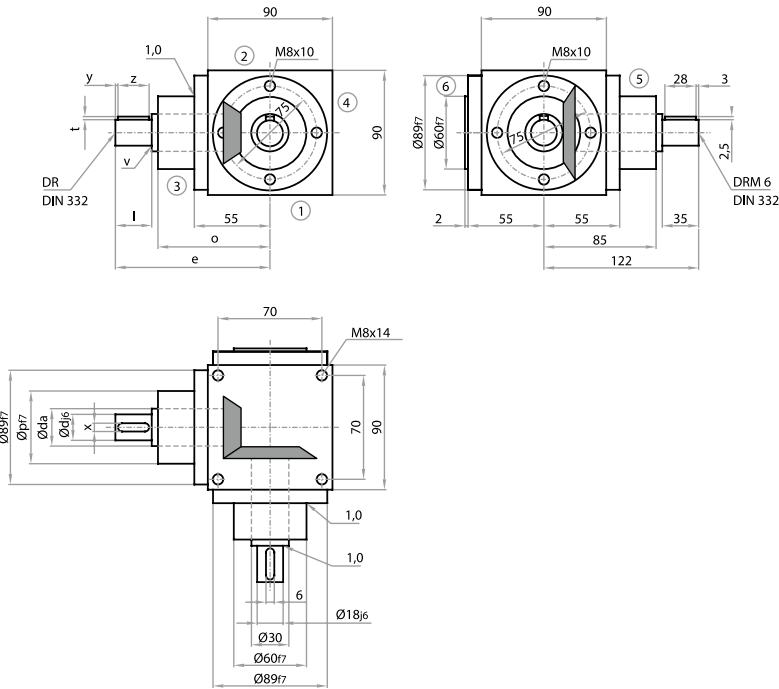

Design

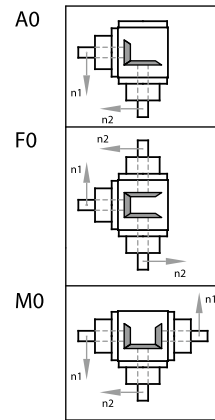

Caution: standard mounting threads in the housing only on sides 1, 2 & 4
Alternatively also possible on sides 3, 5 & 6 in the gird size 75 x 75.

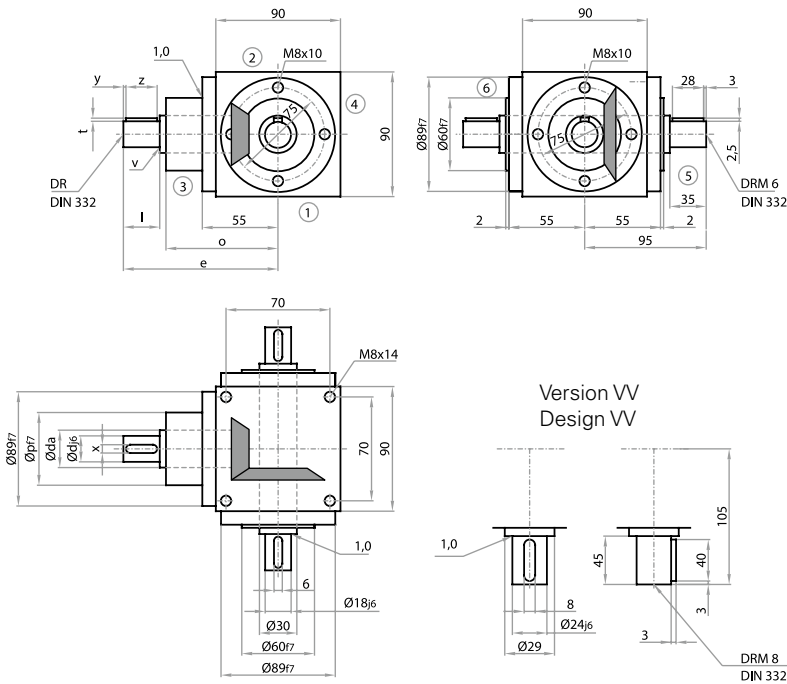

Design

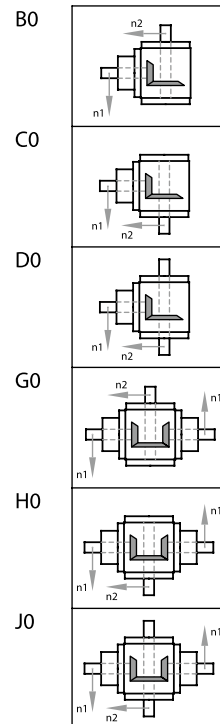

Achtung: Caution: standard mounting threads in the housing only on sides 1, 2 & 4
Alternatively also possible on sides 3, 5 & 6 in the gird size 54 x 54.

Transmission ratio

Transmission ratio	d	da	l	v	x	y	z	t	DR	e	o	p
i = 1:1 - 2:1	18	25	35	1	6	3	28	2.5	M6	122	85	60

Transmission ratio	d	da	l	v	x	y	z	t	DR	e	o	p
i = 3:1	12	20	35	0.5	4	3	28	1.5	M4	122	85	60

Transmission ratio	d	da	l	v	x	y	z	t	DR	e	o	p
i = 4:1	12	20	35	0.5	4	3	28	1.5	M4	132	95	60

Transmission ratio	d	da	l	v	x	y	z	t	DR	e	o	p
i = 5:1 - 6:1	12	20	35	0.5	4	3	28	1.5	M4	132	95	60

Bevel gearbox Type V 090

Performances, torques

[n = min-1, P = kW, T = Nm]

i = n1	1:1 n2	P1N T2N	1,5:1 n2	P1N T2N	2:1 n2	P1N T2N	3:1 n2	P1N T2N	4:1 n2	P1N T2N	5:1 n2	P1N T2N	6:1 n2	P1N T2N
3000	3000	8.93 27.00	2000	5.51 25.00	1500	3.80 23.00	1000	2.54 23.00	750	1.90 23.00	600	1.52 23.00	500	1.25 23.00
2400	2400	7.41 28.00	1600	4.59 26.00	1200	3.17 24.00	800	2.12 24.00	600	1.65 25.00	480	1.32 25.00	400	1.09 25.00
1500	1500	5.29 32.00	1000	3.20 29.00	750	2.23 27.00	500	1.49 27.00	375	1.12 27.00	300	0.89 27.00	250	0.74 27.00
1000	1000	3.75 34.00	667	2.35 32.00	500	1.71 31.00	333	1.14 31.00	250	0.85 31.00	200	0.68 31.00	167	0.53 29.00
750	750	3.06 37.00	500	1.93 35.00	375	1.32 32.00	250	0.88 32.00	187.5	0.66 32.00	150	0.53 32.00	125	0.40 29.00
500	500	2.20 40.00	333	1.36 37.00	250	0.94 34.00	167	0.63 34.00	125	0.47 34.00	100	0.37 34.00	83	0.27 29.00
250	250	1.21 44.00	167	0.74 40.00	125	0.50 36.00	83	0.33 36.00	62.5	0.25 36.00	50	0.20 36.00	42	0.14 30.00
50	50	0.28 50.00	33	0.16 45.00	25	0.10 37.00	17	0.07 37.00	12.5	0.05 37.00	10	0.04 37.00	8.3	0.03 33.00
P1Nt		3.80		3.80		3.80		3.80		3.80		3.80		3.80
T2max		105.00		45.00		80.00		70.00		70.00		60.00		50.00

Radial forces (N)

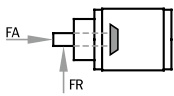

T2 Nm	n1 (1/min)					
	3000	1000	500	250	100	50
< 30	300	400	470	580	700	800
> 30	250	330	390	490	590	670

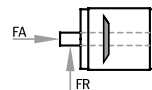

n2 (1/min)						
	3000	1000	500	250	100	50
	500	660	800	950	1250	1500
	420	550	670	790	1040	1250

For further explanations and reinforced bearings, see General
Axial forces FA = 50% of the radial forces - see General

Mass moment of inertia J (kgcm²)

reduced to the drive shaft (n1)

Size	Dimension						
	1:1	1,5:1	2:1	3:1	4:1	5:1	6:1
A0	2.5590	1.4822	1.1437	0.8884	0.3631	0.3248	0.3062
F0	3.8385	2.0508	1.4636	1.0305	0.4430	0.3760	0.3418
M0	3.8385	2.3957	1.9675	1.6346	0.6462	0.5984	0.5769
B0. C0	3.3543	2.1833	1.3652	1.0465	0.4607	0.3933	0.3502
D0	3.3827	2.1959	1.3723	1.0496	0.4625	0.3945	0.3510
G0. H0	4.6338	3.0968	2.1890	1.7927	0.7438	0.6669	0.6209
J0	4.6622	3.1094	2.1961	1.7958	0.7456	0.6681	0.6217

Gearbox weight (kg)

Size	approx. weight
A0	5.1
F0	6.3
M0	6.3
B0. C0	5.4
D0	5.5
G0. H0	6.9
J0	7

Bevel gearbox Type V 120

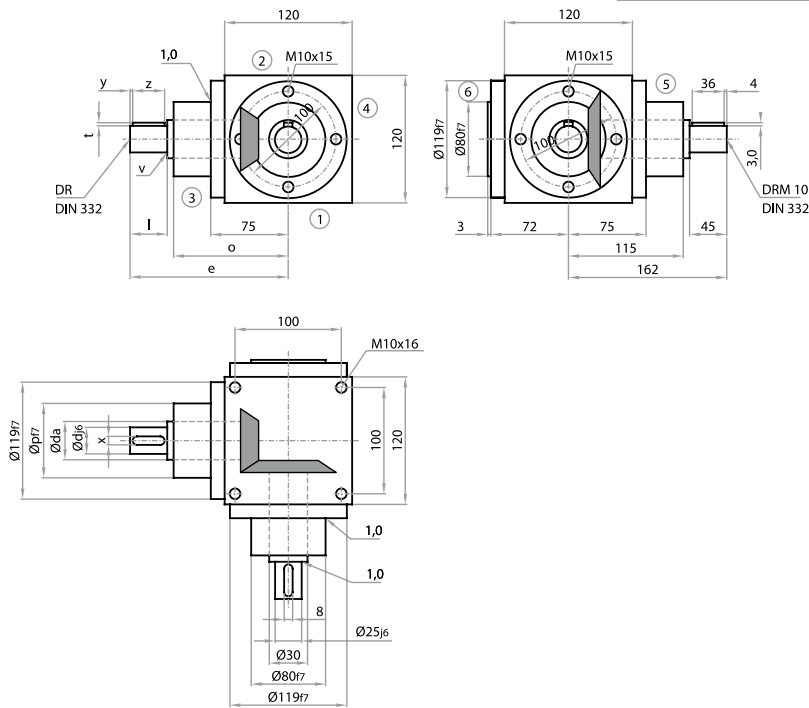

Design

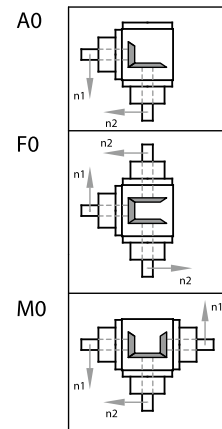

Caution: Standard mounting threads in the housing only on sides 1, 2 & 4.
Alternatively also possible on sides 3, 5 & 6.

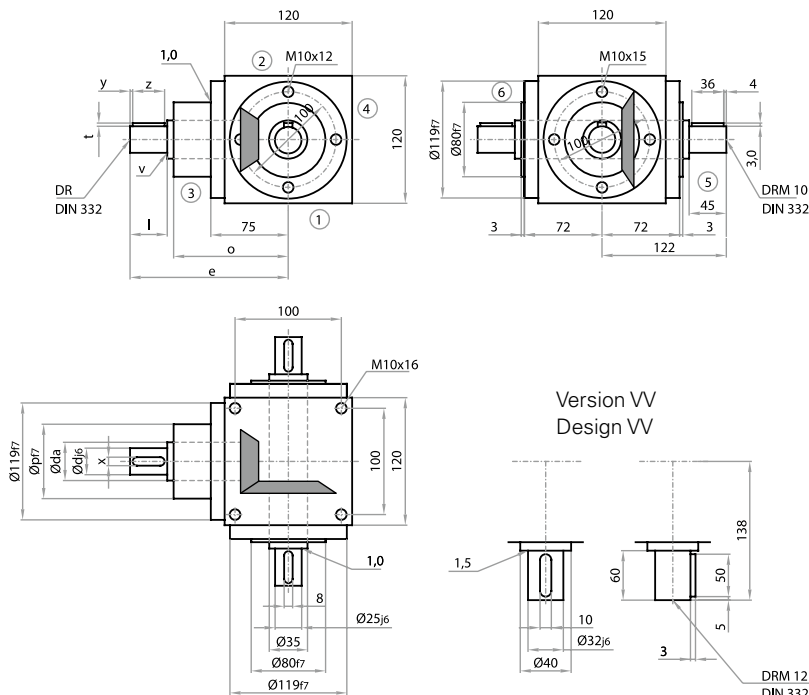

Design

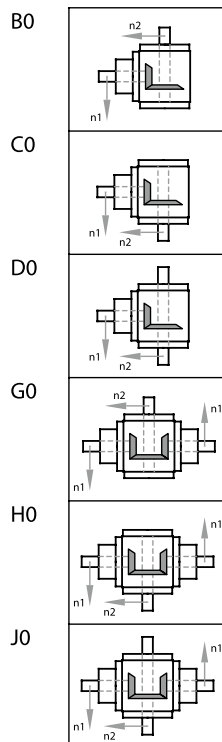

Caution: Standard mounting threads in the housing only on sides 1, 2 & 4.
Alternatively also possible on sides 3, 5 & 6.

Transmission ratio

Transmission ratio	d	da	l	v	x	y	z	t	DR	e	o	p
i = 1:1 - 2:1	25	30	45	1	8	4	36	3	M10	162	115	80

Transmission ratio	d	da	l	v	x	y	z	t	DR	e	o	p
i = 4:1	20	25	45	1	6	4	36	2.5	M6	172	125	80

Transmission ratio	d	da	l	v	x	y	z	t	DR	e	o	p
i = 3:1	20	25	45	1	6	4	36	2.5	M6	162	115	80

Transmission ratio	d	da	l	v	x	y	z	t	DR	e	o	p
i = 5:1 - 6:1	15	20	35	0.5	5	4	28	2	M5	162	125	70

Bevel gearbox Type V 120

Performances, torques

[n = min-1, P = kW, T = Nm]

i = n1	1:1 n2	P1N T2N	1,5:1 n2	P1N T2N	2:1 n2	P1N T2N	3:1 n2	P1N T2N	4:1 n2	P1N T2N	5:1 n2	P1N T2N	6:1 n2	P1N T2N
3000	3000	21.82 66.00	2000	13.45 61.00	1500	9.26 56.00	1000	6.39 58.00	750	4.96 60.00	600	3.97 60.00	500	2.95 54.00
2400	2400	18.52 70.00	1600	11.46 65.00	1200	8.07 61.00	800	5.56 63.00	600	4.43 67.00	480	3.44 65.00	400	2.53 57.00
1500	1500	13.56 82.00	1000	8.60 78.00	750	6.03 73.00	500	4.08 74.00	375	3.06 74.00	300	2.38 72.00	250	1.75 64.00
1000	1000	10.14 92.00	667	6.32 86.00	500	4.46 81.00	333	3.01 82.00	250	2.18 79.00	200	1.76 80.00	167	1.22 66.00
750	750	8.51 103.00	500	5.18 94.00	375	3.55 86.00	250	2.40 87.00	187.5	1.69 82.00	150	1.42 86.00	125	0.94 68.00
500	500	6.34 115.00	333	3.85 100.00	250	2.54 92.00	167	1.66 90.00	125	1.16 84.00	100	0.98 89.00	83	0.63 69.00
250	250	3.39 123.00	167	1.99 100.00	125	1.35 98.00	83	0.87 95.00	62.5	0.60 87.00	50	0.51 92.00	42	0.33 71.00
50	50	0.72 130.00	33	0.41 100.00	25	0.29 107.00	17	0.21 110.00	12.5	0.12 90.00	10	0.10 95.00	8.3	0.06 66.00
P1Nt T2max		6.20 220.00		6.20		6.20		6.20		6.20		6.20		6.20

Radial forces (N)

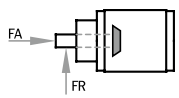

T2 Nm	n1 (1/min)			
	3000	1000	500	250
< 12	180	250	300	350
> 12	150	210	250	290

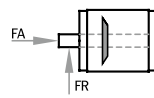

n2 (1/min)			
3000	1000	500	250
300	400	500	650
250	330	420	540

For further explanations and reinforced bearings, see General

Axial forces FA = 50% of the radial forces - see General

Mass moment of inertia J (kgcm²)

reduced to the drive shaft (n1)

Size	Dimension			
	1:1	1,5:1	2:1	3:1
A0	0.3888	0.2406	0.1839	0.1036
F0	0.5832	0.3270	0.2325	0.1252
M0	0.5832	0.3948	0.3192	0.1856
B0, C0	0.4231	0.3111	0.2330	0.1001
D0	0.4330	0.3155	0.2355	0.1012
G0, H0	0.6175	0.4653	0.3683	0.1821
J0	0.6274	0.4697	0.3708	0.1832

Gearbox weight (kg)

Size	approx. weight
A0	12,6
F0	15
M0	15
B0, C0	12,3
D0	12,5
G0, H0	14,7
J0	14,9

Mounting side

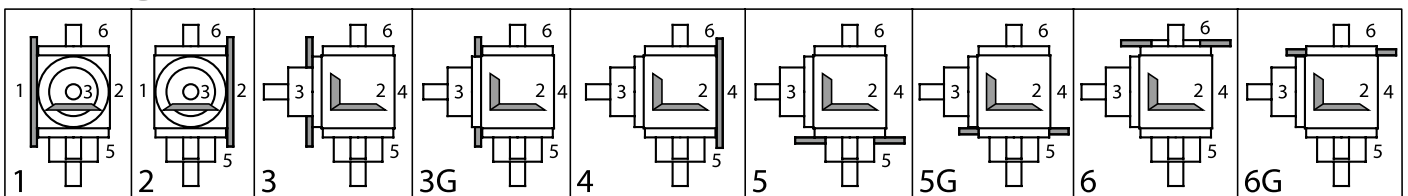

Installation positions (gearbox side underneath)

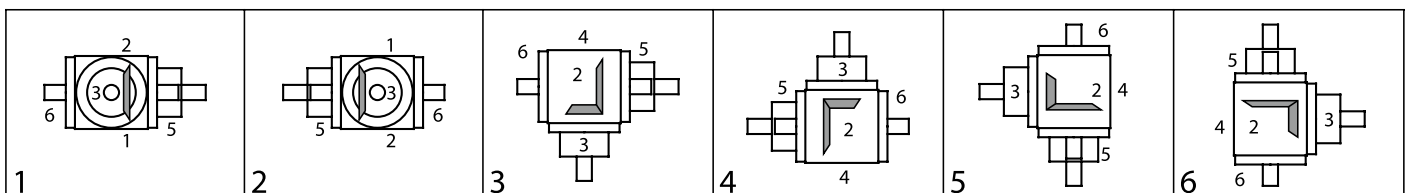

Ordering code

Bevel gearbox

Ordering code Bevel gearbox

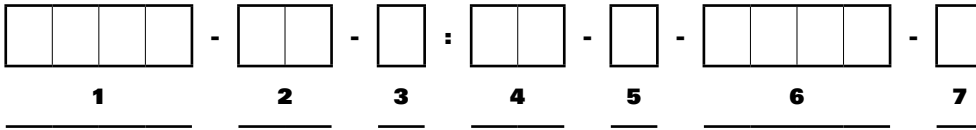

No.	Designation	Code	Description
1	Size	NV 65	
		NV 90	
		NV 120	
2	Design	A0, F0	see pages 108/110/112
		M0, B0	
		C0, D0	
		G0, H0, J0	
3	Transmission ratio	1:1	Gearboxes available for all sizes
		1,5:1	
		2:1	
		3:1	
4	Mounting side	1, 2, 3	see page 113
		3G, 4, 5,	
		5G, 6, 6G	
5	Installation position	1, 2, 3, 4,	see pages 106/113
		5, 6	
6	Speed in [rpm]		Specify maximum output speed
7	Special requirements	0	None
		1	According to specification, description or drawing

Installation and maintenance

Installation of worm gear screw jack systems

Direction of rotation

Before starting installation work, the direction of rotation of all worm gear screw jacks, bevel gear boxes and the drive motor must be checked with regard to the feed direction of each individual worm gear screw jack.

Alignment errors

All components must be carefully aligned during installation. Alignment errors and stresses increase power consumption and lead to overheating and premature wear. Before a drive unit is attached, each worm gear screw jack should be turned through its entire length by hand without load. Variations in the amount of force required and/or axial marks on the outside diameter of the spindle indicate alignment errors between the worm gear screw jack and its additional guides. In this case, the relevant mounting bolts must be loosened and the worm gear screw jack turned through by hand again. If the amount of force required is now constant throughout, the appropriate components must be aligned. If not, the alignment error must be localized by loosening additional mounting bolts.

Test run

The direction of rotation of the complete system and correct operation of the limit switches must be checked again before attaching the drive motor. In the case of version N (translating screw jack), check that the spindle is lubricated with grease from the interior of the gear box and relubricate if necessary. In the case of version R (rotating screw jack), the screw jack should be coated with suitable grease to provide lubrication for lifting operation. The first test runs can then be carried out without load. A maximum operating time of 30 % cannot be exceeded at trial runs under weight for worm gear screw jacks with trapezoidal spindles.

Operation

The loads, speeds of rotation and operating conditions specified for the worm gear screw jacks and transmission components must not be exceeded, even briefly. Failure to observe this condition will invalidate all claims under guarantee.

Guiding values for the mounting of bearing covers

Type	Tightening Torque [Nm]
M 0	3
M 1	5
M 2	9
M 3	13
M 4	32
M 5	60
J 1	70
J 2	150
J 3	150
J 4	220
J 5	300

Maintenance of worm gear screw jacks

Safety

All mounting bolts must be retightened after a short period of operation. Under extreme operating conditions, the wear on the screw nut (worm gear) must be checked at shorter intervals, depending on the duty cycle, by inspecting the backlash in the thread. The screw nut (worm gear) must be replaced if the axial backlash with a single-start thread is more than one-quarter of the thread pitch.

Lubrication

The worm gear screw jacks are lubricated by the manufacturer and are ready for operation on delivery. The versions N/V must be lubricated via their grease nipples with one of the greases specified below at intervals of 50 – 100 operating hours, depending on the grease seepage and in cases of high duty cycles. The spindle should be cleaned and greased at the same time. We recommend that the gearbox be cleaned to remove old grease and refilled with fresh grease after approx. 1500 operating hours or 36 months.

The worm gear screw jacks can be dismantled relatively easily:

- Unscrew the two threaded pins securing the bearing cover.
- Unscrew the spindle and remove the spindle protection if necessary.
- Unscrew the bearing cover with the aid of a face spanner.

Proceed as follows to refit the bearing cover: fit the bearing cover firmly (using approx. ten times the force shown in the table of "Guiding values for fitting the bearing cover").

Then release it and refit it with the guiding value from the table, at the same time checking the axial backlash and smooth running.

Standard grease:
Neff Grease 2

Optional greases:
Castrol Spheerol BM2
Mobil Mobilgrease XHP
Shell Retinax HD2
Klüber Microlube GBO

Lubrication per screw jack

Type	Filling quantity [kg]
M 0	0.03
M 1	0.06
M 2	0.14
M 3	0.24
M 4	0.8
M 5	1.1
J 1	1.5
J 2	2.0
J 3	2.0
J 4	2.7
J 5	3.2

Telescopic Screw Drive S-TEG

General technical data



2-stage synchronously extending telescopic screw drive as glide screw drive version or as ball screw drive version.

As proven "N" design version – "Lifting screw" - or as non-rotating variant of the "VK" design, optionally with safety nut and integrated limit switches.

Standardised connecting options on request for gear, toothed belt or for the direct connection of a drive motor by means of a motor adapter flange or coupling. The different variants can be selected on the basis of the product code.

General technical data:

- The intelligent drive unit ensures continuous torque and clearance throughout the entire stroke.
- Reduced friction values due to Teflon-coated aluminium materials (glide screw version)
- The safety nuts for the glide screw version may optionally be set for fracture or wear.
- For the ball screw version, nuts from the standard product range are used, thus ensuring availability of stock goods and quick replacement.

Technical specifications:

Max. stroke power with ball drive:	16400 N
Max. stroke power with glide screw drive: ¹⁾	10500 N
Maximum stroke length:	up to 2400mm > 2400mm on request
Stroke per revolution of the drive shaft:	10mm Up to 100mm on request
Axial clearance with ball screw drive:	0.1mm (standard) <0.1mm on request
Axial clearance with glide screw drive:	max. 0.4mm <0.4mm on request
Accuracy classes:	T7: 52µm/300mm ²⁾ T9: 130µm/300mm T10: 210µm/300mm
Efficiency with ball screw drive:	0.76
Efficiency with glide screw drive:	0.21 (version: 10mm stroke per revolution) 0.68 (version: 100mm stroke per revolution)
Idling torque with ball screw drive:	0.054 Nm
Idling torque with glide screw drive:	0.133 Nm
Maximum admissible drive torque:	30Nm

1) Depending on the pv value (load x speed)

2) Only available for ball screw version

S-TEG-N-VK with Screw Jack M3

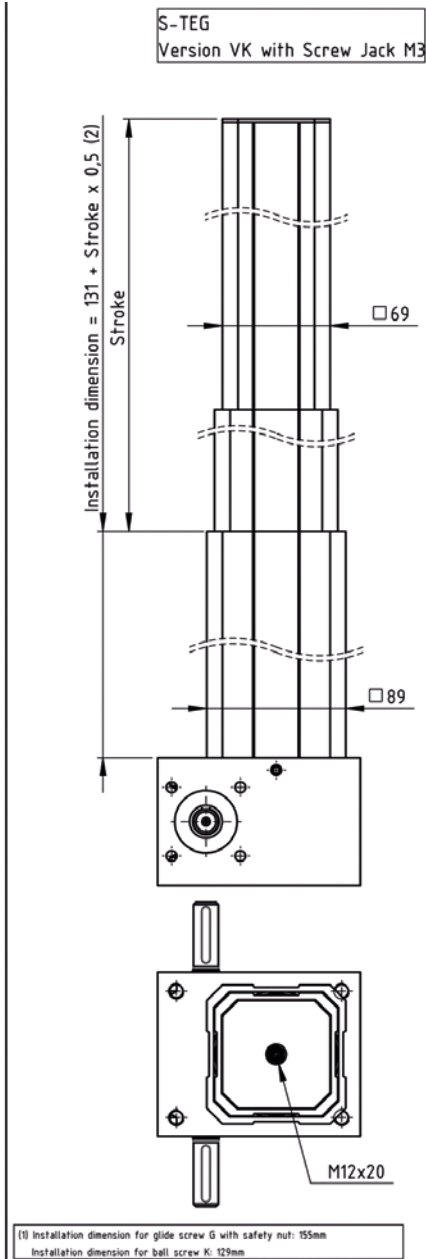
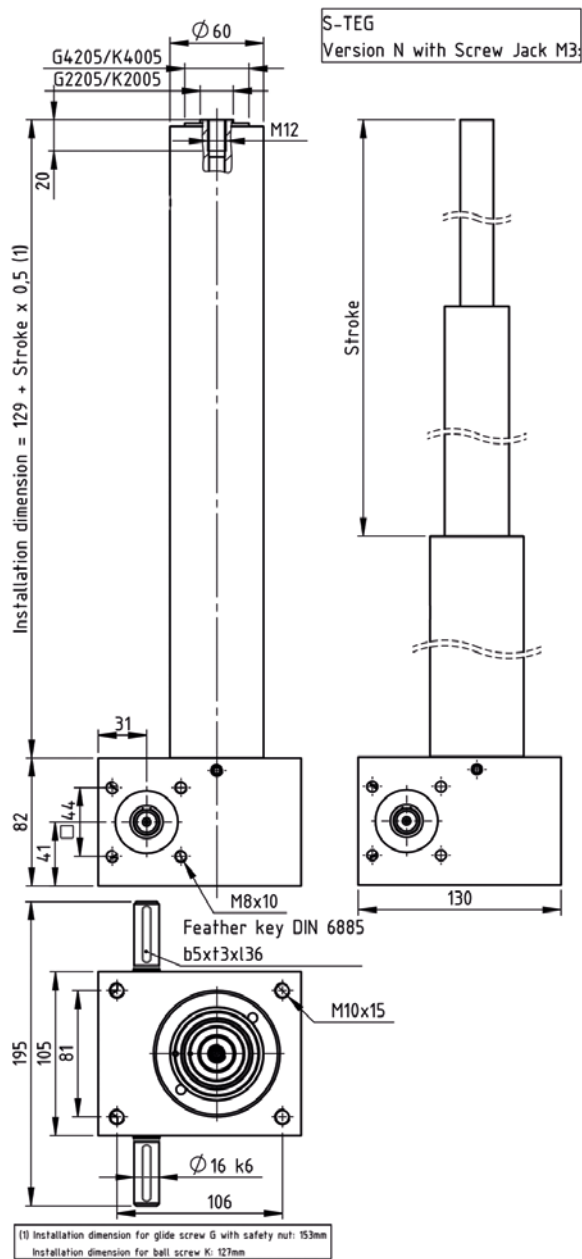

*optional with translation 6 : 1 or 24 : 1

S-TEG-N-VK with adapter flange AF

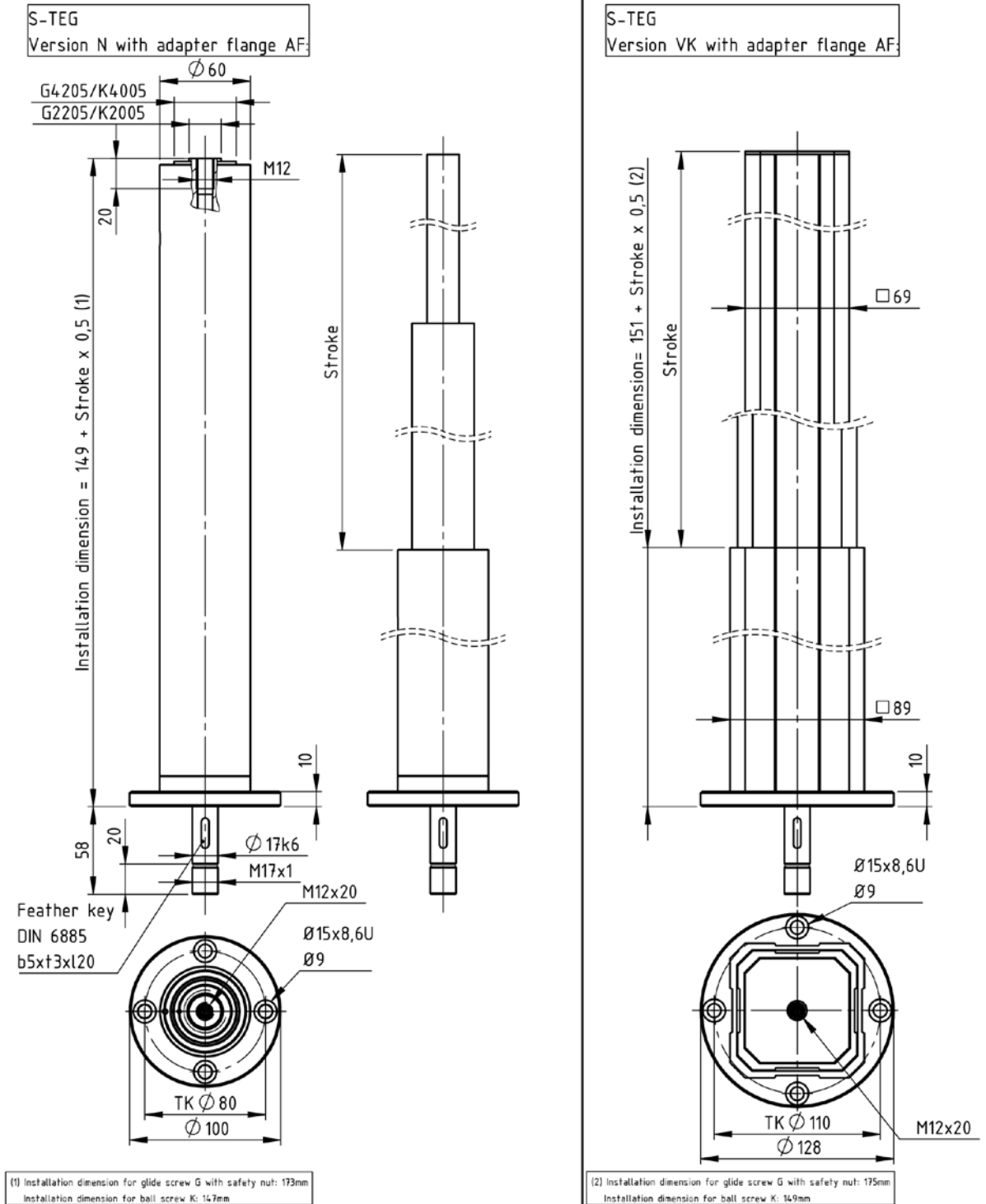

S-TEG-N-VK with High Speed Screw Jack G1

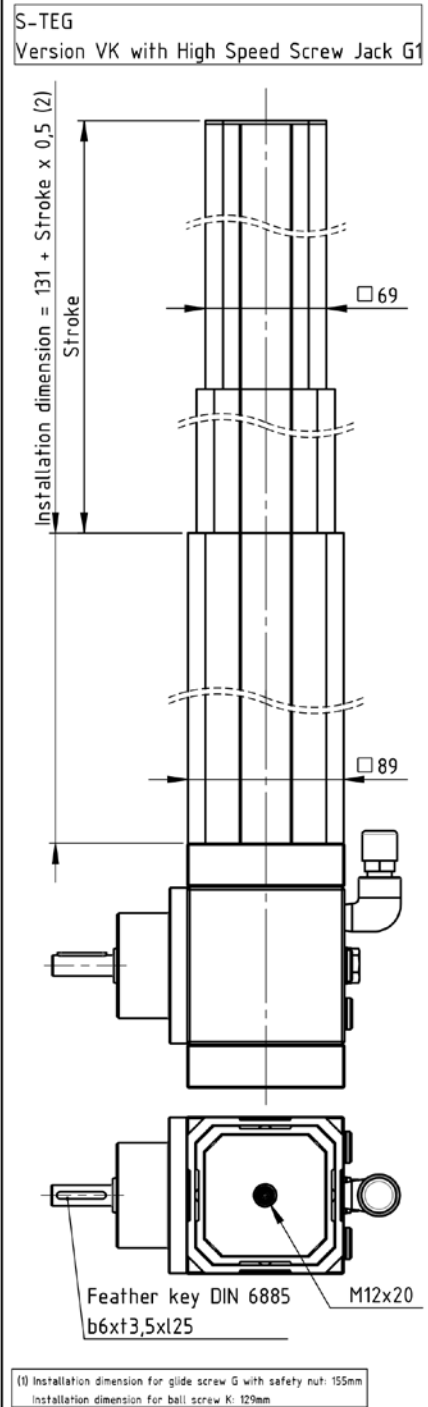
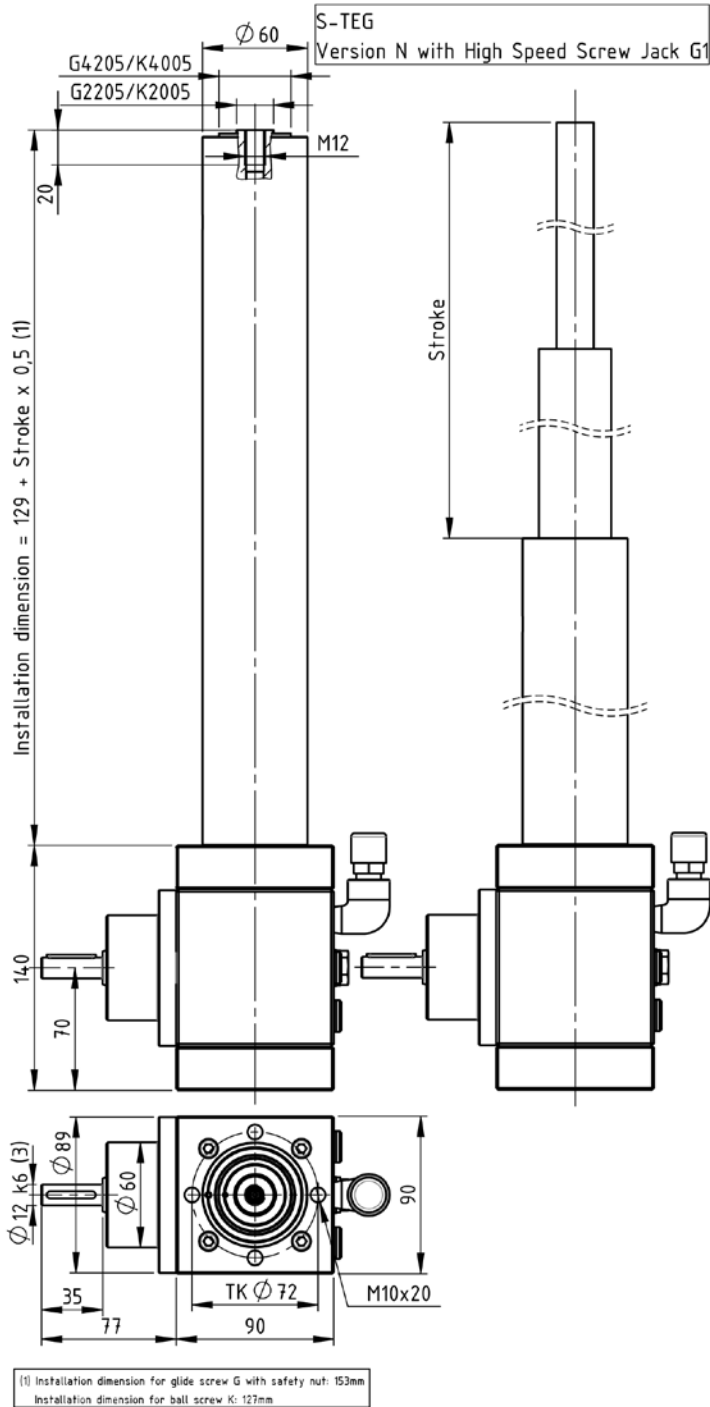

* optional with translation 2:1 or 3:1

Ordering Code

Synchron-Telescope drive

S_TEG

(1) (2) (3) (4) (5) (6) (7) (8) (9) (10) (11)

□-□□□□-□□□□-□□□□□-□□□□□-□□□□-□□□□□-□□□□□-□□□□□-□□□□□-□□□□□-□□□□□-□□□□□-□

No.	Designation	Code	Description
(1)	Product abbreviation	S-TEG	Synchron-Telescop drive
(2)	Design	N VK	Lifting screw Lifting screw (protected against twisting by square tube)
(3)	Screw design	G K	Glide screw Ball screw
(4)	Screw size	4205-2205 4005-2005	Standard for Glide screw: 1. Step: 4205= Ø 42mm, 5mm Pitch 2. Step: 2205= Ø 22mm, 5mm Pitch Standard for ball screw: 1. Step: 4005= Ø 40mm, 5mm Pitch 2. Step: 2005= Ø 20mm, 5mm Pitch
(5)	Accuracy class of the screw	T7 T9 T10	52µm/300mm (Only for ball screw) 130µm/300mm 210µm/300mm
(6)	Safety nut	0 SFM	none Safety nut (Only for glide screw)
(7)	Stroke		Stroke length in [mm]
(8)	Attached parts screw end	0 BP HG	none (M12 Threaded) With Top plate BP With High Performance Joint Plug HGK
(9)	Attached parts driving side	AF MG M3 G1	With adaper flange AF With mounted Screw Jack M3 With mounted High Speed Screw Jack G1
(10)	Limit switches	0 IEND	none With inductive limit switches
(11)	Special requirements	0 1	none According to specificatin, description or drawing

Bellows FB

For the protection of the spindle against external influences. Available in diameters from 20 mm to 120 mm in 1 mm steps. Horizontal and vertical installation possible.

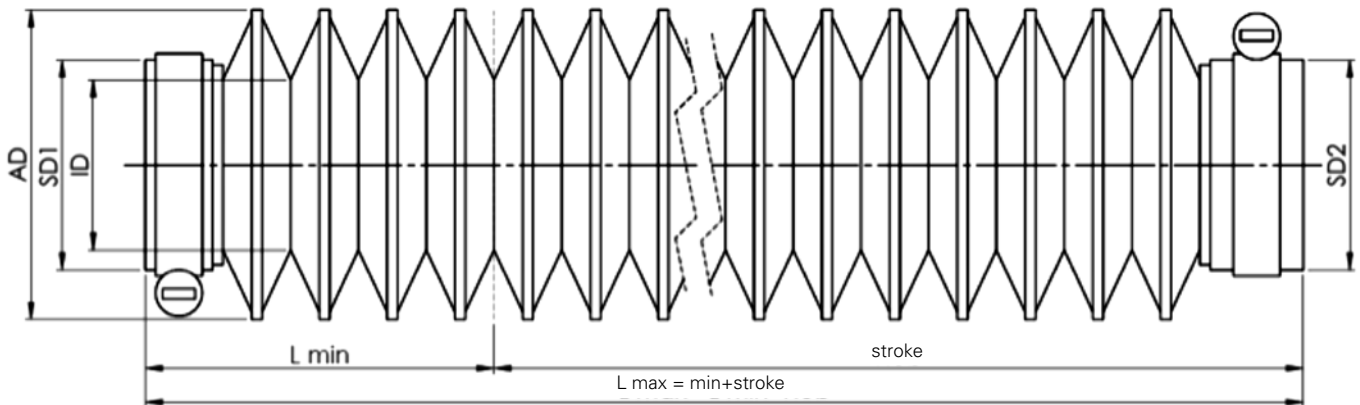

Calculation of bellows FB

For the dimensioning of the spindle length of screw jacks or screw drives with bellows protection, the spindle must be extended by L_{min} .

TO version (thermoplastic sprayed)

$$L_{min} = F_z \cdot L_{minF}$$

$$F_z = \frac{L_{max}}{F_t} : 1,8$$

$$F_t = \frac{AD - ID}{2}$$

$$L_{minF} = 6 \text{ mm}$$

If space is limited, L_{minF} can be shortened after consultation to the factor 0.835.

SB version (disk bellows)

$$L_{min} = F_z \cdot L_{minF}$$

$$F_z = \frac{L_{max}}{F_t} \cdot 1,1$$

$$F_z = \frac{L_{max}}{F_t} : 1,1$$

$$F_t = \frac{AD - ID}{2}$$

$$L_{minF} = 2,5 \text{ mm}$$

L_{min}	compressed length [mm]
L_{max}	extended length [mm]
F_t	fold depth [mm]
F_z	no. of folds
L_{minF}	compressed length per fold [mm]

If space is limited, L_{minF} can be shortened after consultation to the factor 0.64.

A support ring must be installed every 400 mm in case of horizontal installation or every 1000 mm in case of vertical installation. The dimension L_{min} is extended here by 1.1 mm per support ring.

Ordering code

bellows FB

Ordering code for bellows FB

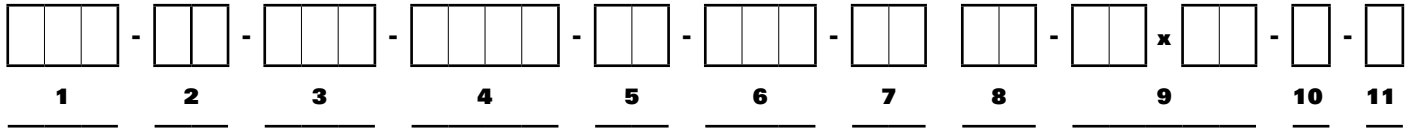

No.	Designation	Code	Description
1	Product abbreviation	FB	Bellows
2	Design	TO	Thermoplastic (sprayed)
		SB	Disk bellows
		GR	Round fabric, coated
		GV	Polygonal fabric, coated
3	Lmin in [mm]		Retraction length / compressed length of bellows
4	Stroke/Lmax in [mm]		Stroke/maximum extension length
5	Inside diameter ID in [mm]		> same as diameter of spindle
6	Outside diameter AD in [mm]		Outside diameter of bellows
7	Cuff diameter SD1 in [mm]		Inside diameter of bellows ending 1
8	Cuff diameter SD2 in [mm]		Inside diameter of bellows ending 2
9	Spindle dimension		e.g. 20x4 (diameter 20 mm, pitch 4 mm)
10	Installation position	H	Horizontal
		V	Vertical
11	Special requirements nut	0	none
		1	According to specification, description or drawing

Spiral spring cover SF

Spiral springs are used as reliable spindle protective covers against external influences.

The material used is hardened spring band steel. If the spiral springs are exposed to cooling lubricants with a high water content, it is recommended to use stainless spiral springs. For dimensions see Accessories pages 49 to 51

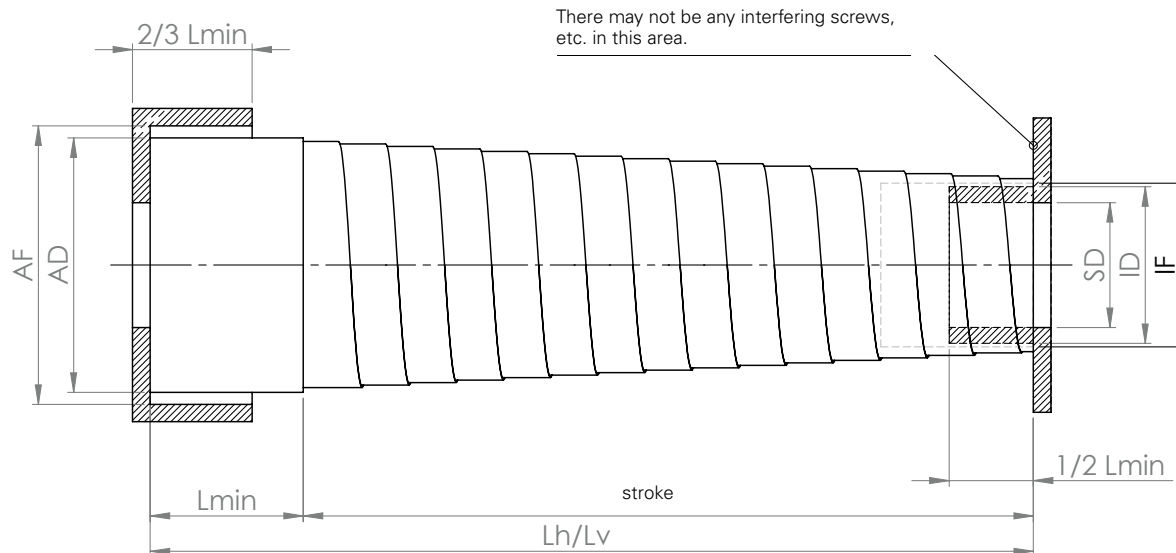

SD = Maximum outside diameter / spindle diameter
 ID = Inside diameter of the spiral spring ± 1 mm
 AD = Diameter of the spiral spring
 Lh = Maximum extension length in case of horizontal installation

Lv = Maximum extension length in case of vertical installation
 BB = Width of band, corresponds to L_{min}
 AF = Inside diameter of the centring flange AD +4 mm
 IF = Outside diameter of the centring flange ID -2 mm

Ordering code spiral spring cover

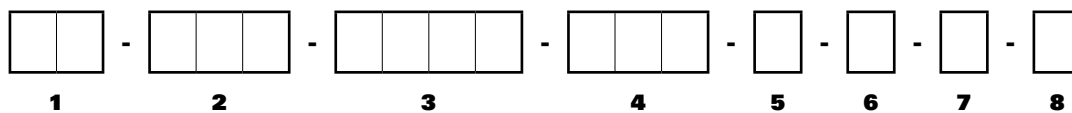

No.	Designation	Code	Description
1	Product abbreviation	SF	
2	ID in [mm]		Inside diameter of the spiral spring +1 mm
3	Largest length Lh/Lv in [mm]		Maximum extension length
4	BB / L_{min} in [mm]		Width of band, corresponds to L_{min}
5	Installation position	H	Horizontal
		V	Vertical
6	Material	B	Standard spring in blued spring steel
		S	Version in rustproof stainless steel
7	Accessories (If using mounting flanges the possible spindle diameter SD is reduced by 6 mm)	0	Without mounting flange
		1	With mounting flange outside (inside diameter +4 mm of outer diameter OD of spiral spring)
		2	With mounting flange inside (inside diameter -2 mm of inner diameter ID of spiral spring)
		3	With mounting flange inside/outside
8	Special requirements for mounting flange	0	None
		1	According to specification, description or drawing

Spiral spring cover SF

For KGT-3210/4005 For TGT-Dm 40

Spiral spring SF	SD	AD	Lh
ID-Lv-BB			
50-100-20	46	66	na
50-150-30	46	63	150
50-150-40	46	61	150
50-200-30	46	65	200
50-250-30	46	68	250
50-250-40	46	68	250
50-250-50	46	62	250
50-300-40	46	64	300
50-350-30	46	73	300
50-350-40	46	66	350
50-350-50	46	66	350
50-400-50	46	68	400
50-450-50	46	70	450
50-500-50	46	72	500
50-500-100	46	70	500
50-550-40	46	74	550
50-550-50	46	73	550
50-550-60	46	68	550
50-600-60	46	72	600
50-650-50	46	76	650
50-650-60	46	73	650
50-700-75	46	79	700
50-750-60	46	80	750
50-750-75	46	78	750
50-800-50	46	81	800
50-800-75	46	79	800
50-900-60	46	81	900
50-900-75	46	84	900
50-1000-60	46	88	900
50-1100-75	46	90	1100
50-1200-75	46	94	1200
50-1250-75	46	95	1250
50-1300-75	46	96	1300
50-1300-100	46	80	1300
50-1350-100	46	82	1350
50-1500-100	46	88	1500
50-1600-100	46	89	1600
50-1650-100	46	90	1650
50-1700-100	46	91	1700
50-1800-100	46	94	1600
50-1900-120	46	96	1900
50-2000-100	46	103	2000
50-2100-120	46	100	2100
50-2200-120	46	103	2200
50-2300-120	46	105	2300
50-2500-150	46	116	2500
50-2600-180	46	105	2500
50-2800-120	46	118	2500
50-3000-120	46	120	2500
50-3000-150	46	123	2500

For KGT 4010/4020/4040 For TGT-Dm 50-55

Spiral spring SF	SD	AD	Lh
ID-Lv-BB			
55-150-30	51	67	150
55-250-30	51	73	250
55-250-50	51	66	250
55-300-40	51	71	300
55-350-50	51	71	350
55-400-50	51	72	400
55-450-40	51	76	450
55-450-50	51	74	450
55-500-40	51	78	500
55-500-50	51	76	500
55-500-60	51	74	500
55-550-50	51	78	550
55-550-60	51	75	550
55-600-50	51	78	600
55-600-75	51	80	600
55-650-60	51	79	650
55-700-50	51	83	700
55-750-60	51	83	750
55-750-75	51	83	750
55-800-60	51	86	800
55-800-75	51	83	800
55-900-60	51	89	900
55-900-75	51	89	900
55-1000-60	51	92	1000
55-1000-75	51	91	1000
55-1100-75	51	94	1100
55-1100-100	51	85	1100
55-1120-120	51	93	1120
55-1300-100	51	89	1300
55-1300-120	51	92	1300
55-1500-100	51	94	1500
55-1500-120	51	94	1500
55-1700-100	51	98	1700
55-1700-120	51	96	1700
55-1800-100	51	102	1800
55-1800-120	51	102	1800
55-1900-100	51	98	1900
55-1900-120	51	100	1900
55-2100-120	51	105	2100
55-2300-120	51	110	2300
55-2500-150	51	118	2500
55-2500-120	51	116	2500
55-2800-120	51	123	2500
55-2800-150	51	121	2500
55-2800-180	51	114	2500
55-3000-180	51	126	2500
55-3250-180	51	130	2500
55-3500-150	51	130	2500
55-3500-200	51	133	2500
55-300-200	51	137	na

For KGT 5010 For TGT-Dm 50-55

Spiral spring SF	SD	AD	Lh
ID-Lv-BB			
65-100-30	61	76	100
65-150-25	61	79	150
65-150-30	61	78	150
65-250-30	61	85	250
65-250-50	61	76	250
65-350-30	61	95	350
65-350-40	61	85	350
65-350-50	61	84	350
65-350-60	61	82	350
65-400-40	61	90	400
65-400-50	61	86	400
65-450-50	61	88	450
65-550-50	61	92	550
65-550-60	61	88	550
65-650-60	61	93	650
65-650-75	61	92	650
65-700-60	61	94	700
65-700-75	61	92	700
65-750-60	61	95	750
65-750-75	61	93	750
65-800-60	61	98	800
65-800-75	61	96	800
65-900-60	61	103	900
65-900-100	61	100	900
65-1000-75	61	104	1000
65-1000-100	61	91	1000
65-1100-75	61	107	1100
65-1100-100	61	95	1100
65-1200-75	61	109	1200
65-1200-100	61	98	1200
65-1300-100	61	99	1300
65-1300-120	61	115	1300
65-1500-75	61	115	1300
65-1500-100	61	108	1500
65-1500-120	61	100	1300
65-1700-100	61	113	1700
65-1700-120	61	106	1700
65-1800-100	61	117	1800
65-1900-120	61	109	1900
65-2000-120	61	111	2000
65-2100-120	61	113	2100
65-2200-120	61	119	2200
65-2300-120	61	118	2300
65-2400-120	61	125	2400
65-2500-120	61	128	2500
65-2600-120	61	126	2500
65-2800-120	61	134	2500
65-3000-150	61	142	2500
65-3250-200	61	138	3250
65-3500-200	61	148	na

For KGT 6310 For TGT-Dm 60-70

Spiral spring SF	SD	AD	Lh
ID-Lv-BB			
75-150-30	71	92	150
75-250-30	71	98	250
75-250-50	71	89	250
75-350-50	71	94	350
75-350-60	71	92	350
75-450-50	71	101	450
75-500-50	71	105	500
75-500-50	71	107	500
75-550-50	71	110	550
75-550-60	71	99	550
75-550-60	71	102	550
75-600-75	71	97	600
75-650-60	71	103	650
75-650-75	71	99	650
75-700-60	71	107	700
75-700-75	71	104	700
75-700-100	71	98	700
75-750-60	71	109	750
75-750-75	71	104	750
75-900-75	71	111	900
75-900-100	71	102	900
75-1000-75	71	114	1000
75-1100-75	71	118	1100
75-1100-100	71	108	1100
75-1200-100	71	112	1200
75-1300-75	71	129	1300
75-1300-100	71	112	1300
75-1500-75	71	125	1500
75-1500-100	71	120	1500
75-1550-100	71	115	1500
75-1700-100	71	124	1700
75-1700-120	71	122	1700
75-1800-100	71	128	1800
75-1800-120	71	122	1800
75-2000-100	71	133	2000
75-2000-120	71	127	2000
75-2000-150	71	135	2000
75-2100-120	71	133	2100
75-2200-100	71	136	2200
75-2200-120	71	132	2200
75-2200-150	71	137	2200
75-2400-100	71	140	2400
75-2400-120	71	137	2400
75-2400-150	71	140	2400
75-2600-120	71	142	2500
75-2600-150	71	144	2500
75-2800-150	71	145	2500
75-2800-180	71	143	2500
75-3250-180	71	156	2500

Spiral spring cover SF

For KGT 8010 For TGT-Dm 80

Spiral spring SF ID-Lv-BB	SD	AD	Lh
100-200-30	96	120	150
100-250-60	96	121	250
100-350-60	96	126	350
100-450-75	96	124	450
100-600-75	96	129	600
100-800-100	96	126	800
100-900-100	96	131	900
100-1000-100	96	132	1000
100-1100-120	96	129	1100
100-1200-100	96	137	1200
100-1300-100	96	140	1300
100-1500-100	96	146	1500
100-1700-120	96	147	1700
100-1800-150	96	151	1800
100-2000-150	96	157	2000
100-2500-150	96	164	2500
100-2800-180	96	168	2800
100-3000-150	96	188	3000
100-3500-200	96	174	2800

For TGT-Dm 100

Spiral spring SF ID-Lv-BB	SD	AD	Lh
120-250-50	116	141	250
120-250-60	116	141	250
120-350-50	116	143	na
120-350-60	116	145	350
120-350-75	116	140	350
120-400-60	115	148	na
120-450-60	116	150	na
120-450-75	116	145	450
120-600-75	116	153	600
120-600-120	116	141	600
120-650-100	116	142	650
120-650-100	116	150	650
120-700-100	116	147	700
120-750-100	116	147	750
120-800-75	116	160	na
120-800-100	116	148	800
120-870-120	116	145	870
120-900-100	116	150	900
120-900-120	116	148	900

For TGT-Dm 100

Spiral spring SF ID-Lv-BB	SD	AD	Lh
120-1100-120	116	153	1100
120-1200-150	116	155	1200
120-1300-120	116	158	1300
120-1300-150	116	156	1300
120-1300-180	116	156	1300
120-1500-120	116	162	1500
120-1500-150	116	163	na
120-1600-180	116	158	1600
120-1800-150	116	167	1800
120-1800-180	116	161	1800
120-2000-150	116	177	2000
120-2000-180	116	169	2000
120-2000-180	116	175	na
120-2200-180	116	174	2200
120-2200-200	116	173	2200
120-2200-200	116	165	1800
120-2400-200	116	170	2400
120-2600-200	116	174	2600
120-2800-200	116	177	2800

For TGT-Dm 120

Spiral spring SF ID-Lv-BB	SD	AD	Lh
140-225-75	136	159	225
140-250-75	136	158	250
140-350-75	136	162	na
140-400-100	136	158	400
140-450-75	136	165	450
140-600-75	136	166	600
140-700-120	136	170	700
140-800-100	136	177	800
140-950-100	136	180	950
140-1000-120	136	192	750
140-1300-150	136	187	na
140-1500-200	136	173	1500
140-1700-200	136	184	na
140-1800-180	136	188	1800
140-1900-200	136	185	na
140-2000-200	136	193	2000
140-2100-180	136	190	2100
140-2400-180	136	200	2100
140-2500-200	136	197	na

Lubricants

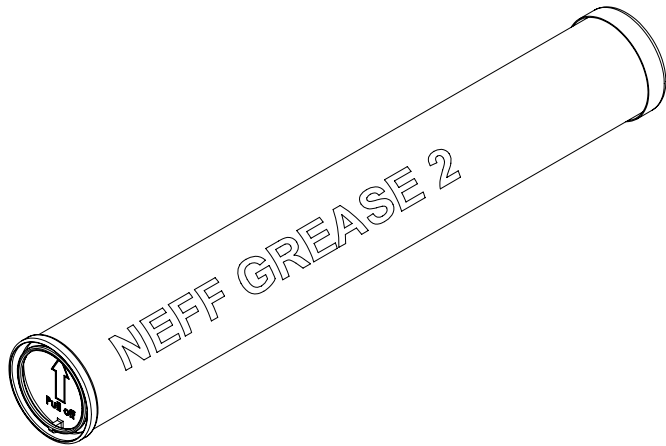

NEFF-Grease 2

Neff Grease 2 was specially developed for use in highly-stressed trapezoidal screw drives, sliding screw drives and worm gear drives.

The heavy-duty grease was specially developed for high surface pressure and has outstanding temperature stability

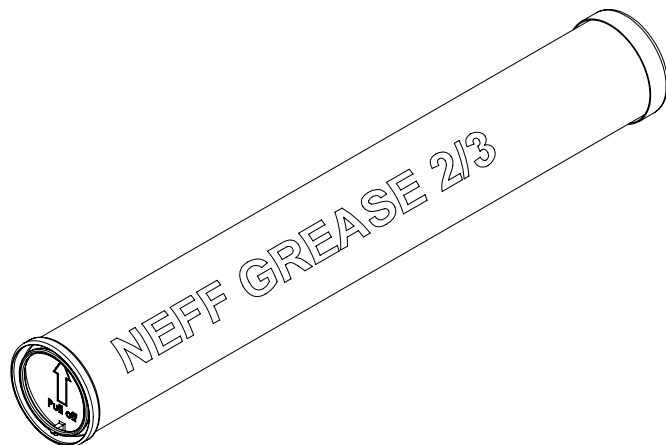

NEFF-Grease 2/3

Neff Grease 2/3 was specially developed for use with highly-stressed ball screw drives.

The strongly adhering synthetic grease containing Teflon has very good temperature stability and can withstand high loads and vibrations.

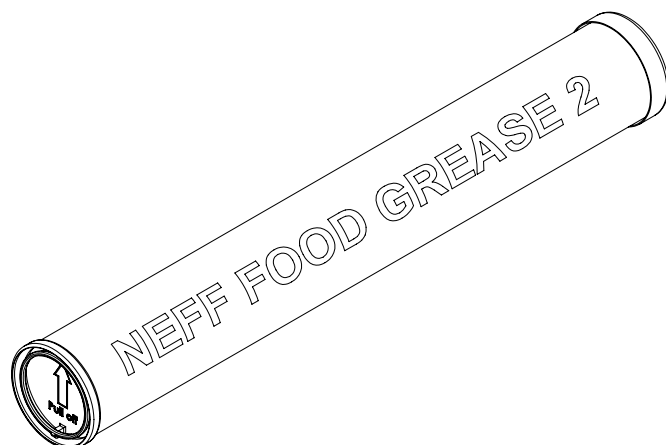

NEFF-Food Grease 2

NEFF Food Grease 2 was specially developed for the requirements of the food industry. The grease meets the requirements of DIN V 10517. Suitable for use in applications with occasional food contact (class NSF-H1).

NEFF Lubricant dispenser

The NEFF Lube 1 automatic lubricant dispenser is screwed directly onto the lubrication point. It operates independently and is activated when setting the running time. The lubricant level is always visible in the transparent window.

Readjustment during operation is possible.

The shelf life of the lubricant dispenser expires after 2 years.

The NEFF Lube 1 lubricant dispenser is available in 4 sizes:

Size	Contents	Length L	Connection	Grease types	Grease delivery per day	Dispensing period
NEFF LUB 1-30	30ml	43mm	R ¼ inch	All standard NEFF Grease types	0.08–8.3 ml	1-12 month
NEFF LUB 1-60	60ml	62mm				
NEFF LUB 1-125	125ml	100mm				
NEFF LUB 1-250	250ml	192mm				

When ordering in conjunction with a ball screw or trapezoidal screw drive, please indicate special requirements of the nut in the ordering code.

Caution: when the lubricant dispenser is mounted the overall height of the NEFF LUB 1 is increased by about 25 mm due to the connecting/adaptor piece

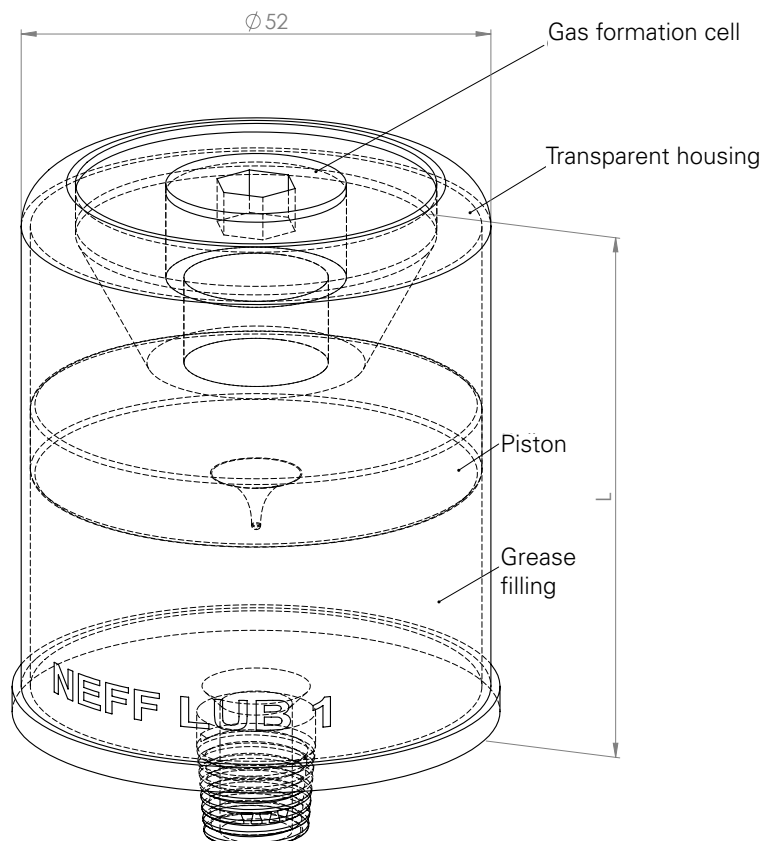

Questionnaire NEFF-KGT/TGT

Contact details

Name:	
Company:	
Department:	
Address:	
Tel.:	
Email:	

Technical specifications

Purpose of use:

Parameters:			
Maximum dynamic load:	N	Maximum static load:	N
Nominal diameter d_0 :	mm	Pitch P:	mm
Pitch direction: (right/left)		Maximum pitch deviation: over 300 mm	μm
Overall length:	mm	Quantity:	
Required maximum feed rate:	m/min	Required stroke length:	mm

Load cycles:			
Load per cycle:	Rotational speed per cycle:	Time portion per cycle:	
N	rpm		%
N	rpm		%
N	rpm		%
N	rpm		%
N	rpm		%

Required service life:	
Service life in cycles:	
Service life in hours of operation:	h
Service life in years of operation:	Y

Installation position:			
Horizontal:	Vertical:	Pivoted:	

Installation case screw ends:			
Fixed bearing-movable bearing:		Fixed bearing-fixed bearing:	
Movable bearing-movable bearing:		Fixed bearing-loose end:	

Ambient conditions:			
Temperature minimum:	°	Temperature maximum:	°
Humidity:		Dust:	Sea air:
Acid:		Wood dust:	Open air:

Questionnaire NEFF-SHG Series M/J/G

Contact details

Name:	
Company:	
Department:	
Address:	
Tel.:	
Email:	

Technical specifications

Purpose of use:	
-----------------	--

Parameters:		
Rotating spindle (version R, lifting movement via nut fixation)		Lifting spindle-not secured against twisting (version N, lifting movement via spindle fixation) ¹
Lifting spindle-secured against twisting by protective tube (version VK, lifting movement via spindle)		Lifting spindle-secured against twisting by feather key (version VP, lifting movement via spindle)
With KGT ball screw		With TGT trapezoidal screw
With GGT sliding screw		With PGT planetary roller screw

Parameters:			
Maximum lifting capacity:	N	Max. static load:	N
Required stroke length:	mm	Required repeatability:	¹ / ₁₀₀ mm
Overall length:	mm	Quantity:	
Required maximum feed rate:	m/min		

Load type:			
Compressive load:		Tensile load:	
Reversierbelastung:		Compressive and tensile load:	
Impact load:		Load by vibration:	

Self-locking:	
Worm gear screw jack stopped by motor, no self-locking required	
Self-locking from lifting movement required	
Self-locking at standstill required	

Safety regulations/Danger to persons:	
Worm gear screw jack with safety nut	

Questionnaire NEFF- SHG Series M/J/G

Duty cycle/Load cycles:			
Duty cycle per day			h
Duty cycle per hour		%	min
Load per cycle:	Rotational speed per cycle:	Time portion per cycle:	
N	rpm		%
N	rpm		%
N	rpm		%
N	rpm		%
N	rpm		%

Required service life:	
Service life in cycles:	
Or service life in hours/years of operation:	h/Y

Installation position:							
Waagrecht:		Senkrecht stehend:		Senkrecht hängend:		Schwenkbar:	

Installation case worm gear screw jack-screw end:			
Screw end with movable bearing: (version R)		Screw end loose	
Screw end universal-mounted:		Worm gear screw jack and screw end universal-mounted:	
Screw end fixed by guides (version N/VK/VP)			

Ambient conditions:					
Temperature minimum:		Temperature maximum:		Dry:	
Humidity:		Dust:		Sea air:	
Acid:		Wood dust:		Open air:	

General attachments:			
Mounting bars BL		Three-phase motor	
Universal joint adapter KA		Servomotor	
Universal joint bearing flange KAF		Handwheel HR	
Universal joint bearing pedestal KLB		Safety handwheel SHR	
Bellows FB		Lubricant dispenser	
Spiral spring cover SF		Spindle grease 400-ml cartridge	
Motor adapter flange MG		Limit switch END	

Attachments version R (rotating spindle)		Attachments version N/VK/VP (fixed spindle)	
Movable bearing unit BF		Mounting plate BP	
		Fork end GK	
Movable bearing unit FF		Spherical bearing GA	
		High-performance joint head HG	



Notes

Contact person Sales

📍 Heilbronn



Sales Manager

Stephan Hankel
Phone: +49 (0) 7131/27177-77
Fax: +49 (0) 7131/27177-66
email: s.hankel@neff-gt.de

📍 Weil im Schönbuch



Sales Screw drives

Dieter Sautter
Phone: +49 (0) 7157/53890-13
Fax: +49 (0) 7157/53890-25
email: d.sautter@neff-gt.de

📍 Weil im Schönbuch



Sales Screw jacks

Sandro Garofano
Phone: +49 (0) 7157/53890-16
Fax: +49 (0) 7157/53890-25
email: s.garofano@neff-gt.de

📍 Heilbronn



Sales Screw drives, Screw jacks

Sandra Benkerdt
Phone: +49 (0) 7131/27177-70
Fax: +49 (0) 7131/27177-66
email: s.benkerdt@neff-gt.de

Contact person Design

📍 Weil im Schönbuch



Design Screw drives

Andreas Ries
Phone: +49 (0) 7157/53890-23
Fax: +49 (0) 7157/53890-25
email: a.ries@neff-gt.de

📍 Weil im Schönbuch



Design Screw jacks

Stephan Steck
Phone: +49 (0) 7157/53890-19
Fax: +49 (0) 7157/53890-25
email: s.steck@neff-gt.de

📍 Heilbronn



Design Screw jacks

Serkan Sinirci
Phone: +49 (0) 7131/27177-75
Fax: +49 (0) 7131/27177-66
email: s.sinirci@neff-gt.de



Contact

NEFF Gewindetriebe GmbH
Karl-Benz-Str. 24
71093 Weil im Schönbuch
Postbox 1230
71108 Waldenbuch
Germany

Phone: +49 (0) 71 57/53890-0
Fax: +49 (0) 71 57/53890-25
www.neff-gewindetriebe.de
info@neff-gewindetriebe.de